



HYDRAULIC COMPRESSION HEAD

หัวย้ำ และ ลูกย้ำ

CO-400A ลูกย้ำตัวยู่

เครื่องมือย้ำหางปลาไฮดรอลิก
ย้ำได้ตั้งแต่ 16 มม² ถึง 400 มม²



CO-400A Dies

CO-400B ลูกย้ำหกเหลี่ยม

เครื่องมือย้ำหางปลาไฮดรอลิก
ย้ำได้ตั้งแต่ 16 มม² ถึง 400 มม²



CO-400B Dies

CO-400A, CO-400B

- Single-action compression tool, lightweight, easy to operate and carry.
- The material of tool made of high carbon steel, heat treatment, not easily deformed.
- Shaped head, accessory dies can be replaced, point and hexagon compression type, compression maximum size up to 400mm².
- Need to coordinate with hydraulic pump (power pump: CTE-25AS, hand pump: CP-700-T, or foot pump: CFP-800).
- Able to customize dies in any sizes.

CO-500B

- Single-action compression tool, lightweight, easy to operate and carry.
- The material of tool made of high carbon steel, heat treatment, not easily deformed.
- Shaped head, accessory dies can be replaced, hexagon compression type, compression maximum size up to 500mm²
- (which can be pressed aluminum cable sleeve).
Need to coordinate with hydraulic pump (power pump: CTE-25AS,
- hand pump: CP-700-T, or foot pump: CFP-800).
Able to customize dies in any sizes.

CO-500B ลูกย้ำหกเหลี่ยม

เครื่องมือย้ำหางปลาไฮดรอลิก
ย้ำได้ตั้งแต่ 70 มม² ถึง 500 มม²



Dies

CO-630A ลูกย้ำหกเหลี่ยม

เครื่องมือย้ำหางปลาไฮดรอลิก
ย้ำได้ตั้งแต่ 70 มม² ถึง 630 มม²



Dies

CO-630A

- Single-action compression tool, lightweight, easy to operate and carry.
- The material of tool made of high carbon steel, heat treatment, not easily deformed.
- U-shaped head, accessory dies can be replaced, hexagon compression type, compression maximum size up to 630mm²
- (which can be pressed aluminum cable sleeve).
Need to coordinate with hydraulic pump (power pump: CTE-25AS,
- hand pump: CP-700-T, or foot pump: CFP-800).
Able to customize dies in any sizes.
Accessory a set of standard die, additional dies can be purchased separately.

CO-630B ลูกย้ำหกเหลี่ยม

เครื่องมือย้ำหางปลาไฮดรอลิก
ย้ำได้ตั้งแต่ 150 มม² ถึง 630 มม²



CP-700-T

	ราคาลูกย้ำ	คู่ละ
CO-630A (ตัวผู้-ตัวเมีย)		9,300.-
CO-630B (ตัวผู้-ตัวเมีย)		9,300.-
CO-500B (ตัวผู้-ตัวเมีย)		3,450.-
CO-400A, CP0-400A (ตัวผู้-ตัวเมีย)		2,950.-
CO-400B, CPO-400B (ตัวผู้-ตัวเมีย)		3,100.-

- Single-action compression tool, lightweight, easy to operate and carry. The material of tool made of high carbon steel, heat treatment, not easily deformed.
- U-shaped head, accessory dies can be replaced, hexagon compression type, compression maximum size up to 630mm² (which can be pressed aluminum cable sleeve).
- Need to coordinate with hydraulic pump (power pump: CTE-25AS, hand pump: CP-700-T, or foot pump: CFP-800).
Able to customize dies in any sizes.
- Accessory a set of standard die, additional dies can be purchased separately.

Item	Output (Ton)	Body weight (Kg)	Net weight (Kg)	JIS	AWG	DIN	Compressed die sizes (mm ²)	Remark	ราคา (ไม่รวมปั๊ม)
CO-400A	17	4.3	6	325	750	400	Male 16-70,95-150,185-400 Female 16-25,35,50-70,95,120,150,185-240,300,400	Point	16,700.-
CO-400B	17	4.3	7.7	325	750	400	16-25,35,50-70,95,120,150,185-240,300,400	Hexagon	23,100.-
CO-500B	20	6.9	10.2	400	1,000	500	70,95,120-150,185,240,300,400,500	Hexagon	33,400.-
CO-630A	35	15.4	17.1	500	1,200	630	70-100,120-150,185-240,300,400,500,630	Hexagon	75,000.-
CO-630B	30	9.9	10.1	500	1,200	630	150,185-240,300,400,500,630	Hexagon	75,000.-

หมายเหตุ : ปั๊ม CP-700-T = 13,800, ปั๊ม CP-700-2A = 16,500 รายละเอียดปั๊มดูที่หน้า 369

*ขอสงวนสิทธิ์ในการเปลี่ยนแปลงราคา



HYDRAULIC CRIMPING TOOLS

เครื่องมือหาลงปลาไฮดรอลิก

■ CPO-400A

เครื่องมือหาลงปลาไฮดรอลิกแบบยี่ ด้วยมือยี่ได้ตั้งแต่ 16 มม² ถึง 400 มม²



■ CPO-400B

เครื่องมือหาลงปลาไฮดรอลิกแบบยี่ ด้วยมือยี่ได้ตั้งแต่ 16 มม² ถึง 400 มม²



■ CPO-150S

ใช้น้ำมัน 2 จังหวะคอนแรง โดยอัตโนมัติหัวยี่สามารถปรับมุมได้ 180° ยี่ได้ตั้งแต่ 16 มม² ถึง 185 มม²



■ CYO-400B

เครื่องมือหาลงปลาไฮดรอลิกแบบยี่ด้วยมือยี่ได้ตั้งแต่ 16 มม² ถึง 400 มม²



■ CPO-400A, CPO-400B

- High pressure direct type hydraulic compressed tool, manually operation entering oil by high and low two-stage output, the maximum output pressure is 700kgf / cm² (10000psi).
- Easy to operate and carry, suitable for high-altitude operations.
- Accessory dies can be replaced, point and hexagon compression type, compression maximum size up to 400mm².
- 17-shaped and 180° rotatable head part, can make use of variety of angles.
- With the overload-protective device.
- Able to customize dies in any sizes.

■ CPO-150S

- High pressure direct type hydraulic compressed tool, manually operation entering oil by high and low two-stage output, the maximum output pressure is 700kgf / cm² (10000psi).
- Easy to operate and carry, suitable for high-altitude operations.
- Accessory dies can be replaced, point compression type, compression maximum size up to 185mm². 180° rotatable head part, can make use of variety of angles.
- With the overload-protective device.

■ CYO-400B

- Single-action compression tool, lightweight, easy to operate and carry. The material of tool made of high carbon steel, heat treatment, not easily deformed.
- C-shaped head, opening 30mm and 38mm, accessory dies can be replaced, hexagon compression type, compression maximum size up to 400mm². Also suitable for crimping brass, copper terminal and C-type, H-type terminals for overhead work especially outside operation for electricity conductors, power companies and general house wiring crimping.
- Need to coordinate with hydraulic pump (power pump : CTE-25AS, hand pump: CP-700-T, or foot pump: CFP-800).
- Able to customize dies in any sizes.

■ SELECTION CHART (Applicable Range)

Item	Output (Ton)	Body weight (Kg)	Net weight (Kg)	JIS	AWG	DIN	Compressed die sizes (mm ²)	Remark	ราคา
CPO-400A	17	7	8.7	325	750	400	Male 16-70,95-150,185-400 Female 16-25,35,50-70,95,120,150,185-240,300,400	Point	31,500.-
CPO-400B	17	7	10.4	325	750	400	16-25,35,50-70,95,120,150,185-240,300,400	Hexagon	40,000.-
CPO-150S	10	4.6	4.7	150	300	185	Male 16-70,95-185 Female 16-25,35,50-70,95,120,150,185	Point	24,000.-
CYO-400B	12	4.6	6.1	325	650	400	16,25,35,50,70,95,120,150,185,240 300, 400	Hexagon	41,700.-

หมายเหตุ : - CYO-400B พร้อมลูกยี่ตั้งแต่ 50, 70, 95, 120, 150, 185, 240, 300, 400 มม. สำหรับ 16, 25, 35 มม. *บีมต้องซื้อแยกต่างหาก*
- บีม CP-700-T = 13,800, บีม CP-700-2A = 16,500 รายละเอียดบีมดูที่หน้า 369

ราคาลูกยี่	คู่ละ
CYO-400A/B	2,750.-
CO/CPO-400A	2,950.-
CO/CPO-400B	3,100.-

TEND

BANDEX

TAKAMURA

TEEFLEX

KENION

NISSEI

ROSI

APEKS

LKEW

TAC

MARLOW

HARU

WIND
SPEED

COMMAX

ADVANTE

UNIVERSAL
ADAPTER

ALION

EXOWELD

CONTROL
MAX

JKN

SYLVIA

WANG

MACCON



HYDRAULIC COMPRESSION

คีมย้ำหางปลาไฮดรอลิก

■ TERMINALS UP TO 16 mm² – 240 mm²

■ CPO-240



- High pressure direct type hydraulic compressed tool, manually operation entering oil by high and low two-stage output, the maximum output pressure is 700kgf / cm² (10000psi).
- Easy to operate and carry, suitable for high-altitude operations.
- Accessory dies can be replaced, hexagon compression type, compression maximum size up to 240mm².
- H-shaped and 180° rotatable head part, can make use of variety of angles.
- With the overload-protective device.
- Able to customize dies in any sizes.

34,000.-

ราคาชุดยี่ห้ ชุดละ

2,600.-

■ FEATURES

- Terminal pressed dies match DIN, AWG, JIS, standard. Head can revolve 180.
- One person operated and convenient in high altitude work. Have safe-protecting device.

■ COMPRESSED TYPE

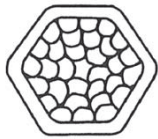

Hexagon



- Figure of assembling and dismantling dies.



- Figure of returning oil switch.

Item	Output (Ton)	Body weight (Kg)	Net weight (Kg)	JIS	AWG	DIN	Compressed die sizes (mm ²)	Remark	ราคา
CPO-240	10	4.2	6.1	250	500	240	16,25,35,50,70,95,120,150,185,240	Hexagon	34,000.-



HYDRAULIC COMPRESSION

คีมย้ำหางปลาไฮดรอลิก

■ CYO-400A

Compressed head made with iron



ราคาลูกย้ำ ชุดละ 2,750.-
69,800.-

■ CHARACTERS

1. Two-section of high, low pressure, quick entering oil, easy operation and convenient returning oil. Using revolving type of compression to be quick returning oil.
2. When the pressure reaches up 700 kg/cm²(12 ton) the design of safe releasing pin has the voice of "Ka Cha" for warning the operator to stop all actions.
3. The glass-fiber operative insulating club can resist voltage 20kv and keep five minuites, which has been tested by Taipai power company.
4. The compressed head can do 180° of revolution.
5. There is a pressure adjusting valve outside of the machine not to take off the structure.
6. Use the beautiful plastic box for packing.
7. C type of Ti-tanium alloy head is easy to convenient to operate in high altitudes high durability, high extension acid-resisting, acid-alkali, which is best material for aviation, submarine industry to use.

* Opening 38 mm can press pincer compressed tube, LGF 35~95 mm²

■ Figure for Specifications

Model	CYO-400A
Compressed Capacity	16 ² ~ 400 mm ² (enclosed 50-400 mm ²) 9 Sets
Ton	12
Strike	30 mm / 38 mm (CYO-400C)
Oil Capacity	145 cc
Voltage	20,000 V/5 min (Between Handle Grips)
Weight (Kg)	6.4 (Steel) / 5 (Ti) / 7.8 (CYO-400C)
Usable Oil	R32 Special circle oil

■ APPLICATIONS

Designed to accommodate hexagonal, circular shell and indue type dies for applying compression fitting to copper, aluminum and ACSR conductors.



หมายเหตุ : CYO-400A พร้อมลูกย้ำตั้งแต่ 50, 70, 95, 120, 150, 185, 240, 300, 400 มม.² สำหรับ 16, 25, 35 มม.² ต้องซื้อแยกต่างหาก

■ HOW TO CHANGE DIES

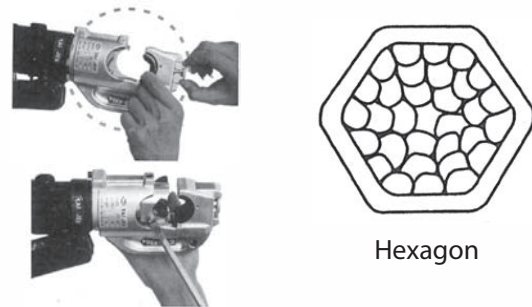

Hexagon

- High pressure direct type hydraulic compressed tool, manually operation entering oil by high and low two-stage output, the maximum output pressure is 700kg/cm² (10000psi).
- Easy to operate and carry, suitable for high-altitude operations.
- C-shaped head, opening 30mm and 38mm, suitable for crimping brass, copper terminal and C-type, H-type terminals for overhead work; especially outside operation for electricity conductors, power companies and general house wiring crimping.
- The operating handle grips are FRP material, can insulated 20KV/ 5 minutes.
- Accessory dies can be replaced, hexagon compression type, compression maximum size up to 400mm². 180° rotatable head part, can make use of variety of angles.
- With the overload-protective device.
- Able to customize dies in any sizes.

Item	Output (Ton)	Body weight (Kg)	Net weight (Kg)	JIS	AWG	DIN	Compressed die sizes (mm ²)	Remark	ราคา
CYO-400A	12	6.2	7.8	325	750	400	50,70,95,120,150, 185,240,300,400	Hexagon	69,800.-



ANGLE-STEEL HYDRAULIC PUNCHING TOOLS

เครื่องมือเจาะรูแผ่นทองแดง, อลูมิเนียมระบบไฮดรอลิก

■ **Single hole type : copper plate, aluminum plate, angle-steel separate type of drilling machine 31ton, 35ton 10,000 PSI**

- Separate type of liquid pressure drilling machine which is available to L, H plate steel copper plate and aluminum plate for punching. There was designed plain seat on the bottom, very steady and smooth.
- Single-hole type of return oil, the dies were made with High-carbon Tungsten alloy steel, not easy to be damaged.

■ CH-60D



เครื่องมือเจาะรูแผ่นทองแดง, อลูมิเนียม, แผ่นเหล็ก ขนาดเจาะแผ่นเหล็กได้สูงสุดหนา 10 มม.

เจาะรูได้ตั้งแต่ขนาด 3/8", 1/2", 5/8", 3/4"

It is use for small copper plate 2mm thickness and 500mm width

ราคาอุปกรณ์ ชุดละ **3,600.-**



■ CH-70-T



เครื่องมือเจาะรูแผ่นทองแดง, อลูมิเนียม, แผ่นเหล็กขนาดเจาะแผ่นเหล็กได้สูงสุดหนา 8 มม. เจาะลึกได้ 110 มม.

เจาะรูได้ตั้งแต่ขนาด 3/8", 1/2", 5/8", 3/4"

WxL Oval size

3/8" (11x19mm), 1/2" (14x21mm), 5/8" (17x24mm)

ราคาอุปกรณ์ ชุดละ **3,600.-**



■ CH-60D

- C-shaped designed, the cylinder and the body are firmly. Integrally molded of forged alloy steel, which possesses both high compression and tension.
 - Light, portable, easy to place. Can precisely punch with few burrs.
 - Applicable to angle steels, copper, aluminum, iron plate, H beams, and all other U-iron. Depth: 70mm. The max. punching capacity: Copper and aluminum plate - D20.5x12mm; Iron plate - D20.5x10mm. Need to coordinate with hydraulic pump (power pump: CTE-25AS, hand pump: CP-700-T, or foot pump: CFP-800). Able to customize dies in any sizes.
- PS: We also offer an oval (rectangular-hole) die for this tool.

■ CH-70-T

- C-shaped designed, is firmly, integrally molded with cast iron.
 - Portable, easy to place. Can precisely punch with few burrs.
 - Applicable to angle steels, copper, aluminum, iron plate, H beams, and all other U-iron.
 - Depth: 80mm. The max. punching capacity: Copper and aluminum - D20.5x12mm; Iron - D20.5x10mm.
 - Need to coordinate with hydraulic pump (power pump: CTE-25AS, hand pump: CP-700-T, or foot pump: CFP-800).
 - Able to customize dies in any sizes.
- PS: We also offer an oval (rectangular-hole) die for this tool.

■ Operation + power pump

Model	Tons	Hole Diameter	Iron plate		Depth(mm)	Weight (kg)	ราคาไม่รวมปั๊ม	ราคารวมปั๊ม
			Copper plate					
CH-60D	31	3/8"~3/4"	6mm	10mm	70	20	58,400.-	72,200.-
CH-70-T	35	3/8"~3/4"	8mm	12mm	85	28	50,000.-	63,800.-

■ Punching number for reference

Hole diameter (inch)	Working pressure (kg/cm ²)	Time		Hole diameter (inch)	Thick ness (mm)	Tons
			Second			
1"	600		35	1"	3.2-10	26.3
3/4"	500		30	3/4"	3.2-12	35
5/8"	450		28	5/8"	3.2-16	50
1/2"	400		28	1/2"	3.2-25	100

Item	Output (TON)	Depth (mm)	Max. Punching Thickness (mm)	Standard Die (mm)	Weight (kg)
CH-60D	31	70	Copper and Aluminum 12 / Iron 10	3/8"(10.5), 1/2"(13.8), 5/8"(17), 3/4"(20.5)	19.5
CH-70-T	35	80	Copper and Aluminum 12 / Iron 10	3/8"(10.5), 1/2"(13.8), 5/8"(17), 3/4"(20.5)	31

*The standard equipment of this item is 4 sets of round hole dies; oval dies must be order separately.

■ CP-700-T



13,800.-

*ขอสงวนสิทธิ์ในการเปลี่ยนแปลงราคา



SLUG-BUSTER PUNCH DRIVER SETS PUNCHER เครื่องมือเจาะรู

■ CC-104 I-T



ขนาด ½" – 2"
ราคา (ชุดตามรูป) 16,700.-
ราคารวมปั๊ม CP -700-T 30,500.-

■ CC-104 II-T (น็อคเอาว์)



ขนาด 2 ½" – 4"
ราคา (ชุดตามรูป) 16,700.-
เครื่องมือเจาะรู (น็อคเอาว์)
เจาะได้ตั้งแต่ขนาด 1/2" - 4"
เจาะแผ่นเหล็กได้หนาสุด 3.2 มม.
SLUG-BUSTER PUNCH DRIVER SETS.

CC-104 I-T

- Applicable to electricity controlling boxes, switchboards, sheet metals, or modifying or adding additional holes.
 - Fast punching without any burrs, notches, nor sparks, which improves the appearance and increases the value of the product.
 - Light, portable, easily changing dies.
- The max. punching capacity: Iron – D60.8(2") x 3mm stainless steel – D60.8(2")x1.2mm.

- Need to coordinate with hydraulic pump (power pump : CTE-25AS, hand pump: CP-700-T, or foot pump: CFP-800). Able to customize dies in any sizes.

CC-104 II-T

- Applicable to electricity controlling boxes, switchboards, sheet metals, or modifying or adding additional holes.
- Fast punching without any burrs, notches, nor sparks, which improves the appearance and increases the value of the product.
- Light, portable, easily changing dies.
- The max. punching capacity: Iron – D115.3(4")x 3mm stainless steel – D115.3(4") x1.2mm. Need to coordinate with hydraulic pump (power pump: CTE-25AS CP-700-T, or foot pump: CFP-800).
- Able to customize dies in any sizes.

แกน	ราคา
R-1	680.-
R-2	1,150.-
R-3	1,800.-

ราคาอะไหล่เฉพาะตัวน็อคเอาว์

ขนาด	ราคา
1/2"	2,300.-
3/4"	2,400.-
1"	2,600.-
1 1/4"	2,800.-
1 1/2"	3,550.-
2"	4,750.-
2 1/2"	5,300.-
3"	6,050.-
4"	6,900.-

Item	Output (ton)	Max. Punching Thickness (mm)	Standard Die (mm)	Weight (kg)
CC-104I-T	12	Iron 3 , Stainless Steel 1.2	1/2"(22), 3/4"(27.5), 1"(34.3), 1 1/4"(43), 1 1/2"(49), 2"(60.8)	10.8
CC-104II-T	-	Iron 3 , Stainless Steel 1.2	2 1/2"(76.6), 3"(89.4), 3 1/2"(102.6), 4"(115.3)	6.4

RATCHET PUNCH

■ MANUAL KNOCKOUT SET WITH RATCHET WRENCH

■ APPLICATIONS

- 1" Hex head Ratchet Wrench allows use with 3/8" (9.5mm) and 3/4" (19.1 mm) draw studs.
- Plastic carrying case. Mild steel 3.0 mm ½" – 2" Conduit Size Manual Slug – Buster Knockout Punch Set.

■ CC-104RW-T

25,000.-



Item	Output (TON)	Max. Puching Thickness (mm)	Standard Die (mm)	Weight (kg)
CC-104RW-T	-	Iron 3, Stainless Steel 1.2	1/2(22), 3/4"(27.5), 1"(34.3), 1 1/4"(43), 1 1/2"(49), 2"(60.8)	3.7

CC-104RW-T

- Starting with drilling a hole on the switchboard, then make the axis through the hole, matching the needed die size, and finishing with putting on the adjustable ratchet wrench, then rotate it.
- Fast punching without any burrs, notches, nor sparks, which improves the appearance and increases the value of the product.
- Saving effort, easily changing dies, light, portable, no need to coordinate with hydraulic pump or cylinder set.
- The max. punching capacity: Iron – D60.8(2")x3mm; Stainless steel – D60.8(2") x1.2mm. Able to customize molds in any sizes.

Hole : ½ (22mm), ¾ (27mm) Size : 1" (34.3mm), 1 ¼ (43mm), 1 ½ (49mm), 2"(60.8mm)

ขนาด(เฉพาะตัวน็อคเอาว์)	ราคา
1/2"	3,000.-
3/4"	3,250.-
1"	3,850.-
1 1/4"	4,700.-
1 1/2"	5,300.-
2"	8,000.-
ปั๊ม	1,250.-
สกรู น็อค ขนาด 3/8"	1,950.-
สกรู น็อค ขนาด 3/4"	2,100.-

TEND
BANDEX
TAKAMURA
TEEFLEX
KENION
NISSEI
ROSI
APEKS
LKEW
TAC
MARLOW
HARU
WIND SPEED
COMMAX
ADVANTE
UNIVERSAL ADAPTER
ALION
EXOWELD
CONTROL MAX
JKN
SYLVIA
WANG
MACCON



POWER PUMP

ปั๊มไฮดรอลิก

CTE-25AS

66,700.-

Two-speed operation

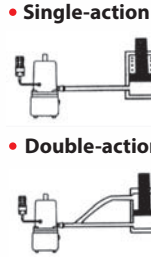
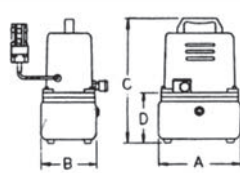
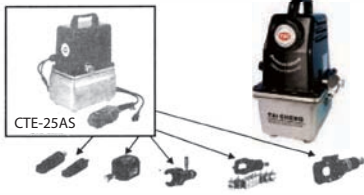

Single-action

- 200 cu in/min @ 0-200 PSI
- 20 cu in/min @ 200 – 10,000 PSI
- 220 volt, 110 volt 60/50 #cycle.
- 3/8 " NPTF return to tank Pot.
- High Pressure Hose 2M.

Double-action

Applications

- The nice outward appearance cast with gravitation and coated to finish; use a carbon-brushmotor output 0.4kw speed, torsion 700kg/cm 10,000 psi standard.
- Power pumps have many functions to contact a lot of functional need.
For instant : Oil cylinder, compressed terminal iron plate, performed, cable, steel cutter, tube bender...etc.

Item	Max. output pressure (kg/cm ² /psi)	Output pressure (kg/cm ²)	Output Oil (L/min)	Motor (kw)	Oil storage (cc)	Net weight (kg)	Size: LxWxH (mm)	ราคา
CTE-25AS	700/10,000	Low 0-20 High 20-700	Low 2.6 High 0.32	1	2,700	14.8	235x255x410	66,700.-

FOOT 700kg/cm 10,000 PSI

สวิตซ์เท้าเหยียบ

CP-700-T



CFP-800



CP-700-2A



CFP-800-1



Features

- 10,000 PSI (700kg/cm) operation
- Two-speed operation
- High Pressure Hose 2M.
- 3/8" NPTF return to tank port.
- Aluminum Hand valve. Super cycle oil each half year, Ready to install oil pressure gauge to test the working pressure.

Selection Chart (applicable range)

Applications

- There are single and two stage designs for our hand pumps. General speaking two-stage is with higher effect more oil output and used by normal.
- **TYPE :** Hand and foot pump.
- **Output :** 700kg/cm 10,000 psi
- **Suggestion :** Using hand type will be the most convenient and mom-power single acting must be change to double-action as well as equipment 4 way valve to use.
- In order to design and match the requirement for large oil cylinder and longer stroke, the pump in itself must equip with a large oil tank. Have to explain on choice.

Item	Max. Output Pressure (kg/cm ² /psi)	Output Pressure (kg/cm ²)	Output Oil (L/min)	Oil Storage (cc)	Net Weight (kg)	Size : LxWxH (mm)	ราคา
CP-700-T	700 / 10,000	Low 0 - 25 High 25-700	Low 13 High 2.3	900	8.3	520x135x150	13,800.-
CP-700-2A	700 / 10,000	Low 0 - 25 High 25-700	Low 13 High 2.3	2,100	12.2	610x150x150	16,500.-
CFP-800	700 / 10,000	Low 0 - 25 High 25-700	Low 13 High 2.3	1,200	12.6	480x155x250	25,000.-
CFP-800-1	700 / 10,000	Low 0 - 25 High 25-700	Low 13 High 2.3	400	10.4	480x155x250	21,000.-



HYDRAULIC CUTTER

คีมตัดสายไฮดรอลิก

The hydraulic cutting tool series cuts both hard and soft classes of wires. The hard wire class including: ACSR aluminum wires with steel cores, soft copper-aluminum iron rods, steel strands, steel cables, reinforcing bars, etc. The soft wire class including: copper-aluminum cables, communication cables, and other wires (hard type tools can also cut the soft wires).

■ CPC-40A (Hard Type)



PS:Cutting steel core ACSR aluminum blade is better recommended 5 degrees.

- A one-shaped EHV-hydraulic cutting machine uses two-stage manual oil output – high and low voltages. The max. output pressure: 700kgf/cm² (10000psi).
- Lightweight, easy to carry and operate, suitable for working high above the ground.
- The special alloy steel blade is made for nicely cutting hard wires without breaking.
- The operating handle grips are made with FRP materials, so it can be insulated from 20KV voltage for 5 minutes.
- The max. cutting opening: D40mm.
- The head part can be rotated upto 180-degree; it is able to coordinate with various angles.

■ CPC-55A (Hard Type)



- A one-shaped EHV-hydraulic cutting machine uses two-stage manual oil output – high and low voltages. The max. output pressure: 700kgf/cm² (10000psi).
- Lightweight, easy to carry and operate, suitable for working high above the ground.
- The special alloy steel blade is made for nicely cutting hard wires without breaking.
- The operating handle grips are made with FRP materials, so it can be insulated from 20KV voltage for 5 minutes.
- The max. cutting opening: D55mm.
- The head part can be rotated upto 180-degree; it is able to coordinate with various angles.

■ CPC-85A (Soft Type)



- A one-shaped EHV-hydraulic cutting machine uses two-stage manual oil output – high and low voltages. The max. output pressure: 700kgf/cm² (10000psi).
- Lightweight, easy to carry and operate, suitable for working high above the ground.
- The special alloy steel blade is made for nicely cutting hard wires without breaking.
- The max. cutting opening: D85mm.
- The head part can be rotated upto 180-degree; it is able to coordinate with various angles.

Item	Output (Ton)	Opening (mm)	Cutting Capacity										Weight (kg)	ราคา
			Steel Wire(mm)		Round Bar(mm)				Stranded Conduct(mm)			Telecom Cable (mm)		
			6x7	6x12	Soft Copper bar	Soft Aluminum bar	Soft Steel bar	Reinforce bar	Steel Aluminum strand	Copper Aluminum strand	Steel wire strand (1x9)			
CPC-40A	7.1	40	25	25	24	24	16	16	38	40	20	40	6	58,400.-
CPC-55A	7.1	55	25	25	24	24	16	18	38	55	20	55	6.5	66,700.-
CPC-85A	5	85	-	-	-	-	-	-	-	28/38	-	85	8.5	65,000.-

TEND
BANDEX
TAKAMURA
TEEFLEX
KENION
NISSEI
ROSI
APEKS
LKEW
TAC
MARLOW
HARU
WIND SPEED
COMMAX
ADVANTE
UNIVERSAL ADAPTER
ALION
EXOWELD
CONTROL MAX
JKN
SYLVIA
WANG
MACCON



HYDRAULIC CUTTER

คีมตัดสายไฮดรอลิก

■ CPC-85B(Soft Type)



- A single-loop cutter tool, lightweight, easy to carry and operate.
- The special alloy steel blade is made for nicely cutting soft wires without breaking.
- The max. cutting opening: D85mm.
- Need to coordinate with hydraulic pump (automatic: CTE-25AS, manual: CP-700-T, or pedal: CFP-800).

■ CPC-40B (Hard Type)



P.S. : It is recommended to use a 5-degree blade to cut an ACSR aluminum wire with steel core.

- A single-loop cutter tool, lightweight, easy to carry and operate.
- The special alloy steel blade is made for nicely cutting soft wires without breaking.
- The max. cutting opening: D40mm.
- Need to coordinate with hydraulic pump (automatic: CTE-25AS, manual: CP-700-T, or pedal: CFP-800).

■ CPC-55B (Hard Type)



- A single-loop cutter tool, lightweight, easy to carry and operate.
- The special alloy steel blade is made for nicely cutting soft wires without breaking.
- The max. cutting opening: D55mm.
- Need to coordinate with hydraulic pump (automatic: CTE-25AS, manual : CP-700-T, or pedal: CFP-800).

Item	Output (Ton)	Opening (mm)	Cutting Capacity										Weight (kg)	ราคา (ไม่รวมปั๊ม)
			Steel Wire(mm)		Round Bar(mm)				Stranded Conduct(mm)			Telecom Cable (mm)		
			6x7	6x12	Soft Copper bar	Soft Aluminum bar	Soft Steel bar	Reinforce bar	Steel Aluminum strand	Copper Aluminum strand	Steel wire strand (1x9)			
CPC-40B	7.1	40	25	25	24	24	16	16	38	40	20	40	5	40,000.-
CPC-55B	7.1	55	25	25	24	24	16	18	38	55	20	55	4.5	41,700.-
CPC-85B	5	85	-	-	-	-	-	-	-	28/38	-	85	6	48,400.-

หมายเหตุ : ปั๊ม CP-700-T = 13,800, ปั๊ม CP-700-2A = 16,500 รายละเอียดปั๊มดูที่หน้า 369

■ CC-50B-A



- A single-loop cutter tool, lightweight, easy to carry and operate.
- The special alloy steel blade is made for nicely cutting soft wires without breaking.
- The max. cutting opening: D50mm (630mm²).
- Need to coordinate with hydraulic pump (automatic: CTE-25AS, manual: CP-700-T, or pedal: CFP-800).

Item	Output (Ton)	Opening (mm)	Cutting Capacity										Weight (kg)	ราคา (ไม่รวมปั๊ม)
			Steel Wire(mm)		Round Bar(mm)				Stranded Conduct(mm)			Telecom Cable (mm)		
			6x7	6x12	Soft Copper bar	Soft Aluminum bar	Soft Steel bar	Reinforce bar	Steel Aluminum strand	Copper Aluminum strand	Steel wire strand (1x9)			
CC-50B-A	12	50	-	-	-	-	-	-	-	50	-	50	5.4	24,200.-

หมายเหตุ : ปั๊ม CP-700-T = 13,800, ปั๊ม CP-700-2A = 16,500 รายละเอียดปั๊มดูที่หน้า 369



BENDER

เครื่องมือดัดท่อ ดัดสายไฟ

■ CPB-3-T IMC, RSC 1/2" - 3"

เครื่องดัดท่อ



- Applicable to indoor electrical wires, water pipes, gas pipes, thick pipes, fire-fighting, and other bending engineer. It can bend and curve smoothly at different angles without wrinkles.
- The max. bending angle: 90 degrees. The max. bending diameter: 3". It can complete bending 1/2"~2" diameters at once; and approx. five times for the 2 1/2"~3" without depression.
- Meets the domestic piping demand, using aluminum alloy and ductile iron as alternatives for materials of bending dies.
- Need to coordinate with hydraulic pump (power pump: CTE-25AS, hand pump: CP-700-T, or foot pump: CFP-800).

■ CPB-4-T IMC, RSC 1/2" - 4"



- Applicable to indoor electrical wires, water pipes, gas pipes, thick pipes, fire-fighting, and other bending engineer. It can bend and curve smoothly at different angles without wrinkles.
- The max. bending angle: 90 degrees. The max. bending diameter: 4". It can complete bending 1/2"~2" diameters at once; and approx. five times for the 2 1/2"~4" without depression.
- Meets the domestic piping demand, using aluminum alloy and ductile iron as alternatives for materials of bending dies.
- Need to coordinate with hydraulic pump (power pump: CTE-25AS, hand pump: CP-700-T, or foot pump: CFP-800).

ราคาอะไหล่เฉพาะตัว

Size	Price
1/2"	5,000.-
3/4"	5,600.-
1"	6,000.-
1 1/4"	6,500.-
1 1/2"	8,000.-
2"	9,000.-
2 1/2"	9,600.-
3"	10,000.-
3 1/2"	12,500.-
4"	13,000.-

■ CP-700-2A



16,500.-

Item	Output (ton)	Thick Steel Tube (B)	Gas Pipe (SGP)	Weight (kg)	ราคา (ไม่รวมปั๊ม)
CPB-3-T	17	D16(1/2")~D82(3")	D15(1/2")~D80(3")	18.6	75,000.-
CPB-4-T	20	D16(1/2")~D104(4")	D15(1/2")~D100(4")	28.8	100,000.-

หมายเหตุ : ปั๊ม CP-700-T = 13,800, ปั๊ม CP-700-2A = 16,500 รายละเอียดปั๊มดูที่หน้า 369

■ Standard Size Chart

Gas pipe (SGP)					Thick steel tube (B)				
Pipe Size	Pipe's Outer Diameter	Pipe's Inner Diameter	Pipe's Thickness	Bending Radius	Pipe Size	Pipe's Outer Diameter	Pipe's Inner Diameter	Pipe's Thickness	Bending Radius
SGP-15(1/2)	21.7	16.1	2.8	60	B16(1/2)	21	16.4	2.3	75
SGP-20(3/4)	27.2	21.6	2.8	80	B22(3/4)	26.5	21.9	2.3	90
SGP-25(1)	34	27.6	3.2	100	B28(1)	33.3	28.3	2.5	130
SGP-32(1 1/4)	42.7	35.7	3.5	130	B36(1 1/4)	41.9	36.9	2.5	195
SGP-40(1 1/2)	48.6	41.6	3.5	160	B42(1 1/2)	47.8	42.8	2.5	230
SGP-50(2)	60.5	52.9	3.8	220	B54(2)	59.6	54	2.8	270
SGP-65(2 1/2)	76.3	67.9	4.2	320	B70(2 1/2)	75.2	69.6	2.8	450
SGP-80(3)	89.1	80.7	4.2	425	B82(3)	87.9	82.3	2.8	500
SGP-90(3 1/2)	101.6	93.2	4.2	550	B92(3 1/2)	100.7	93.7	3.5	500
SGP-100(4)	114.3	105.3	4.2	600	B104(4)	113.4	106.4	3.5	680

TEND
BANDEX
TAKAMURA
TEEFLEX
KENION
NISSEI
ROSI
APEKS
LKEW
TAC
MARLOW
HARU
WIND SPEED
COMMAX
ADVANTE
UNIVERSAL ADAPTER
ALION
EXOWELD
CONTROL MAX
JKN
SYLVIA
WANG
MACCON

TEND

BANDEX

TAKAMURA

TEEFLEX

KENION

NISSEI

ROSI

APEKS

LKEW

TAC

MARLOW

HARU

WIND
SPEED

COMMAX

ADVANTE

UNIVERSAL
ADAPTER

ALION

EXOWELD

CONTROL
MAX

JKN

SYLVIA

WANG

MACCON



BENDER

เครื่องมือดัดท่อ ดัดสายไฟ

■ CPB-19A, CPB-25A, CPB-31A



● Manual Bending E.M.T Pipe Tools (90-degree)

- An aluminum gravity die casting has lightweight, high strength, smooth bending without wrinkling.
- A free bending E.M.T tube has the max. bending angle of 90 degrees.
- Attached with a handle that can easily make a one-time bending.

Item	Applicable E.M.T Tube Diameter (mm)	Bending Angle	Weight (kg)	ราคา
CPB-19	D19	90	0.5	1,000.-
CPB-25A	D25	90	0.8	1,700.-
CPB-31	D31	90	1.5	2,900.-

■ CBH-90 เครื่องดัดสายไฟดัดได้ถึง 750 MCM (500) mm²



● Manual Ratchet Cable Bending Tool

- An aluminum gravity die casting has lightweight, high strength, smooth bending without wrinkling.
- A free bending E.M.T tube has the max. bending angle of 45 degrees.
- Attached with a handle that can easily make a one-time bending.
- Simplifies and cable installation.
- Bends copper or aluminum through 750 MCM (325)
- Packed in carrying case.
- 90 Bending Radius.

Item	Applicable bending range (mm)	Bending Angle	Weight (kg)	ราคา
CBH-90	150 ~ 325	90	3.1	9,200.-



FEMAIL WIRE PROCESSING MACHINE

เครื่องมือตัด, ตัดแผ่นทองแดง, อลูมิเนียม ระบบไฮดรอลิก

■ Hydraulic, separate type to bend and cut the copper plate and aluminum plate.

- Available to switch case, distributed electricity-tray; be automatic to control the distributed cable of engineering use this item easily.
- The opening of copper plate cut by CWC-200V is smooth, which is the excellent item.

■ CWC-150, CWC-200



Tool for cutting copper plate

■ CWC-150V, CWC-200V



Tool for cutting copper plate, V shape of copper clips



เครื่องตัดบัสบาร์ทองแดง, อลูมิเนียม ตัดได้สูงสุดหน้ากว้าง 150 มม. 10 มม.

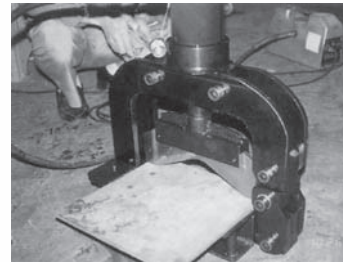

- This series of tools has smaller volume and lighter weight, which is convenient for the users to carry around and operate outside. This series is able to use on processes copper, aluminum, iron, and all types of busbars.

■ CWC-150, CWC-200

■ Busbar Cutting Tool

- Applicable to manufacturing factories, on-off boxes, and switchboard auto-controlled industrial wiring work.
- The horizontal cutter design can avoid wasting material on extra busbar.
- The adjustable bolt helps preventing the busbar from tilted during cutting.
- The max. cutting capacity – CWC-150: 150x10mm (CWC-200: 150x10mm).
- Need to coordinate with hydraulic pump (power pump : CTE-25AS, hand pump: CP-700-T, or foot pump: CFP-800).

■ CWC-150V, CWC-200V

■ V-Shaped Busbar Cutting Tool

- Applicable to manufacturing factories, on-off boxes, and switchboard auto-controlled industrial wiring work.
- The V-shaped cutter design makes the cutting side smoother by avoiding cutting notches.
- The max. cutting capacity – CWC-150V: 150x10mm (CWC-200V: 150x10mm).
- Need to coordinate with hydraulic pump (power pump: CTE-25AS, hand pump: CP-700-T, or foot pump: CFP-800).

Item	Output (ton)	Cutting Capacity (mm)	Weight (kg)	ราคา
CWC-150	16	Copper, Aluminum 150x10m, Iron 150x6	26.5	45,000.-
CWC-200	35	Copper, Aluminum 200x10m, Iron 200x6	31.2	61,700.-
CWC-150V	20	Copper, Aluminum 150x10m, Iron 150x6	23	60,000.-
CWC-200V	20	Copper, Aluminum 200x10m, Iron 200x6	28.7	75,000.-

หมายเหตุ : บีม CP-700-T = 13,800, บีม CP-700-2A = 16,500 รายละเอียดบีมดูที่หน้า 369

■ CP-700-T



13,800.-

- TEND
- BANDEX
- TAKAMURA
- TEEFLEX
- KENION
- NISSEI
- ROSI
- APEKS
- LKEW
- TAC
- MARLOW
- HARU
- WIND SPEED
- COMMAX
- ADVANTE
- UNIVERSAL ADAPTER
- ALION
- EXOWELD
- CONTROL MAX
- JKN
- SYLVIA
- WANG
- MACCON



FEMALE WIRE PROCESSING MACHINE

เครื่องมือดัด, ตัดแผ่นทองแดง, อลูมิเนียม ระบบไฮดรอลิก

- Available to switch case, distributed electricity-tray; be automatic to control the distributed cable of engineering use this item easily.
- The opening of copper plate cut by CWC-200V is smooth, which is the excellent item.

■ CB-150D



■ CB-150D

■ Copper Plate Blending Tool

- Applicable to manufacturing factories, on-off boxes, and switchboard auto-controlled industrial wiring work.
- The liftable design of this tool can easily take out a busbar by taking away the tenon if the busbar is too long or in a bended N-shaped or C-shape.
- The horizontal placement design prevents the busbar from twisted and avoids products leaning one side by firmly supporting the bracket to keep it balanced while bending. Provides angle and scale for controlling the bending angle easily. The max. bending capacity is 150x10mm.
- Need to coordinate with hydraulic pump (power pump:CTE-25AS, hand pump: CP-700-T, or foot pump: CFP-800).

■ CB-200A-T



■ CB-200A-T

■ Busbar Straight-Band Tool

- Applicable to manufacturing factories, on-off boxes, and switchboard auto-controlled industrial wiring work.
- The use of the axis in large-area-bending design prevents the busbar from twisted while bending.
- Provides angle and scale for controlling the bending angle easily. The max. bending capacity is 200x10mm.
- Need to coordinate with hydraulic pump (power pump:CTE-25AS, hand pump: CP-700-T, or foot pump: CFP-800).

Item	Output (TON)	Bending Capacity (mm)	Weight (kg)	ราคา (ไม่รวมปั๊ม)
CB-150D	16	Copper, Aluminum 150x10	17.7	36,700.-
CB-200A-T	16	Copper, Aluminum 200x10	24	33,400.-

หมายเหตุ : ปั๊ม CP-700-T = 13,800, ปั๊ม CP-700-2A = 16,500 รายละเอียดปั๊มดูที่หน้า 369



HYDRAULIC CABLE REEL STANDS AND SPINDLES

เครื่องมือยกสายไฟไฮดรอลิก และชนิดธรรมดา

■ CRS-10 เครื่องมือยกสายไฟไฮดรอลิก สามารถยกได้ 10 ตัน

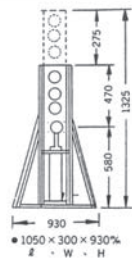

- Using the hydraulic jacks, lift the cable tray up, use bearing drive the cable releasing, easy and effort-saving.
- Suitable for outdoor underground cable line and air-lines operations, house construction and other switchboard wiring.
- With fixed cable tray by wheel seats, so that the tray can keep balance.
- Max. load : 10 Tons.

■ CRS-46 ขายกล้อสายไฟไฮดรอลิก สามารถยกได้ 2 ตัน



- Using the hydraulic jacks, lift the cable tray up, use bearing drive the cable releasing, easy and effort-saving.
- Suitable for outdoor underground cable line and air-lines operations, house construction and other switchboard wiring.
- With fixed cable tray by wheel seats, so that the tray can keep balance.
- Max. load : 2 Tons.

Item	Tonnage (ton)	Stroke (mm)	Height (mm)	Iron bar (mm)	Single frame weight (kg)	Size (mm)	ราคา
CRS-46	2	245	700	D45 x 1,500	16	600 x 260 x 455	48,000.-
CRS-10	10	245	1,325	D57 x 1,700	44	1,050 x 300 x 930	75,000.-

CABLE REEL STANDS AND SPINDLES

■ CRS-5



11,700.-

Weight : 800 kg
Dimension : 450 mm x 760 mm

TEND

BANDEX

TAKAMURA

TEEFLEX

KENION

NISSEI

ROSI

APEKS

LKEW

TAC

MARLOW

HARU

WIND
SPEED

COMMAX

ADVANTE

UNIVERSAL
ADAPTER

ALION

EXOWELD

CONTROL
MAX

JKN

SYLVIA

WANG

MACCON



HYDRAULIC TOOLS

เครื่องมือไฮดรอลิก

■ CCP-2500 เครื่องดึงสายไฟ ชนิด 2 สปีด

175,000.-

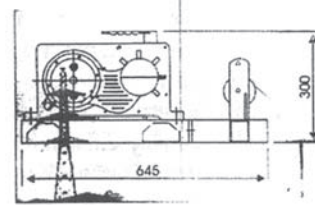
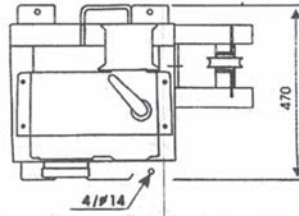

เหมาะสำหรับการเดินสายไฟ, งานร้อยท่อ รวดเร็ว และประหยัดแรงงาน

■ คุณสมบัติพิเศษ

- มีประโยชน์ในการใช้งานสูงเท่ากับแรงดึง 30 คนเสียเครื่องรบกวนต่ำ
- มีระบบป้องกันอัตโนมัติจะตัดไฟเองเมื่อไฟมาปิดปกติมีความปลอดภัยสูง
- สามารถหมุนดึงสายไปข้างหน้าและหมุนกลับ เก็บสายได้สะดวก
- เลือกความเร็วได้ 2 สปีด

■ วิธีการใช้งานก่อนใช้งานควรปฏิบัติดังนี้

- นำเครื่องดึงพันราบเสมอ
- ปรับสปีดความเร็ว หมุนด้ามปรับความเร็วถึงที่เหมาะสมแล้วปล่อยที่ดึงลง
- ตรวจสอบการปรับความเร็วให้ถูกต้อง
- ตั้งสวิตช์ไว้ที่ RESET ตั้งสวิตช์ไว้ที่เดินหน้า
- ปล่อยกระแสไฟเข้า เปิดสวิตช์เท่าเหยียบ
- ล้อสายไฟจะหมุนตามนาฬิกาเหยียบอีกครั้งเครื่องจะหยุด

ความเร็ว	ความเร็วสูง 5 M/ min	ความเร็วต่ำ 3 M/ min
แรงดึง	1,500 kg 30 แรงคน	2,500 kg 50 แรงคน
มอเตอร์	400 W	
ไฟฟ้า	220 V	
น้ำหนัก	60 kg	
อุปกรณ์	สวิตช์ปิด-เปิดเท่าเหยียบ, ลวดสลิง	
อุปกรณ์เลือกซื้อ	ล้อเก็บสาย, แขนดึง	

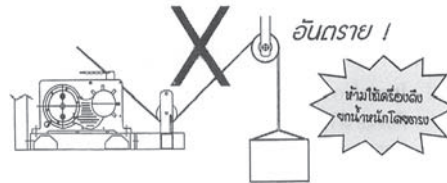

MULTIPLE TYPE

เครื่องมือไฮดรอลิก

■ CO-5250M+T250+250AT

ชุดเครื่องมือไฮดรอลิก ย้ำ และตัด
(ย้ำแบบ Hexagon ขนาด 16-240 mm²)



60,000.-

■ CYO5250M+T250+250AT

ชุดเครื่องมือไฮดรอลิก ย้ำ และตัด
(ย้ำแบบ Hexagon ขนาด 16-240 mm²)

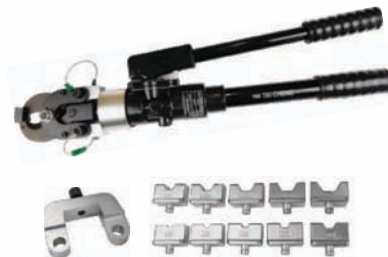

90,000.-

■ 250AT-104I

ชุดเสริม เจาะ
(ขนาด 1/2" ถึง 2")



20,500.-

■ 250AT-104II

ชุดเสริม เจาะ
(ขนาด 2 1/2" ถึง 4")



21,000.-

*ขอสงวนสิทธิ์ในการเปลี่ยนแปลงราคา



STRIPPER

คีมปอกสาย

■ WIRE STRIPPER คีมปอกสาย

ME-A.B.C

730.-



Model	ขนาดสาย
ME-A	0.5 - 2.0 mm ²
ME-B	1.0 - 3.2 mm ²
ME-E	8 - 22 mm ²

MS-107(KS-170)

คีมปอกสาย 0.5mm² - 6mm²



440.-

MD-163(GD-163)

คีมปอกตัด-ย้ำ 1.5mm² - 6mm²



860.-

■ CABLE STRIPPER มีดปอกสาย



Used thumb to press Stripper onto sheath

Make circular cur

Make longitudinal out

Peet away sheach

Old model	New model	ขนาดสาย	Price
CS-16	MS-16	ø4 - 16 mm.	500.-
CS-25	MS-25	ø8 - 28 mm.	500.-

■ MPC 25 คีมตัด PVC

25 mm



Model	ขนาดสาย	Price
MPC-6	0 mm - 25 mm	ø3/4"

■ LY-104 AEG : 10, 12, 14, 16, 18 มีดปอก, ตัด, ย้ำสายไฟ



Old model	New model	Price
LY-104A	MT104I	265.-

LY-104 = 7-in-1 Tool

1. Wire Stripper
2. Wire Cutter
3. Cutter (Solid Wire)
4. Pier
5. Wire Loop
6. Measure Scale
7. Crimp

TEND

BANDEX

TAKAMURA

TEEFLEX

KENION

NISSEI

ROSI

APEKS

LKEW

TAC

MARLOW

HARU

WIND
SPEED

COMMAX

ADVANTE

UNIVERSAL
ADAPTER

ALION

EXOWELD

CONTROL
MAX

JKN

SYLVIA

WANG

MACCON



MARLOW

MULTIFUNCTION TOOLS

เครื่องมือมัลติฟังก์ชัน

MK-80A (CYO-80A) คีมย้ำหางปลา
ย้ำได้ตั้งแต่ 1.5 - 150 มม²



■ Hand type of compressed tools

Ratchet type and pushing type of machine principle action.
Terminal compressed : point type min 1.25 mm², max. 150 mm², hexagonal type min. 6 mm², max. 150 mm²
European DIN 1.5 mm² ~ 150 mm²

- Bare terminal, insulated-compressed terminal, rigidly precise, it not easy fall out.
- Compressed terminal have point type and hexagonal type (hexagonal one is positive at present).
- Wonderful coating and rust resisting - good quality of Chromium Vanadium-steel and machine body manufactured by ISO 9002 of wax-removed precise cast factory.
- Sincere heat treatment, the equipment of treatment controlled by computer comes from ISO 9002 company.

Old model	New model	Name	Size (mm)	Weight (g)	Compressed standard DIN mm ²	Compressed	Price
CYO-80A	MK-80	Open terminal pincer	570	3,160	10, 16, 25, 35, 50, 70, 95, 120	Point	4,660.-

MK-80B (CYO-80B) คีมตัดบัสบาร์และคีมย้ำหางปลา



Copper row hand tool with many functions.

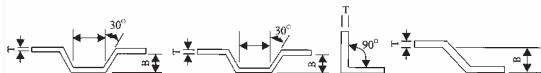

■ Copper Row Hand Tools Terminal Up To 10 mm²~ 50 mm²

- A copper row hand tool with many functions, it has five functions.
- The design for dies is replaceable type.
- Easy to operate, weight is only 3.1 kg.
- Suitable to electric rationed plate, electric distributed plate engineering operation convenient to carry.
- Packed with an iron box.
- The maximum standard to 100A of BH uses 3 mm of copper row, 50A-705A use 2 mm of copper row, below 50A use 1 mm of copper row.

Item number	A	B	T/mm
MK-1001	15	10	1
MK-1002	15	10	2
MK-1003	20	12	3
MK-1004	24	14	3
MK-1005	Terminal 10 ² ~50 ² mm		

COMPRESSED
TYPE

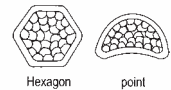

Hexagon point

Old model	New model	Name	Size (mm)	Weight (g)	Compressed standard DIN mm ²	Compressed	Price
CYO-80B	MK-80B	Bas Bar Benders Hand		2,700	ตัดบัสบาร์ถึงขนาด กว้าง 20 มม หน้า 3 มม	-	16,750.-

MK-150 (CYO-150) คีมย้ำหางปลา
ย้ำได้ตั้งแต่ 10 - 150 มม²



Old model	New model	Name	Size (mm)	Weight (g)	Compressed standard DIN mm ²	Compressed	Price
CYO-150	MK-150	Compressed Tool 8-150 SM	685	4,500	10, 16, 25, 35, 50-70, 95, 120-150	Point	7,350.-

*ขอสงวนสิทธิ์ในการเปลี่ยนแปลงราคา



CABLE AND STEEL ROPES CUTTING TOOLS

เครื่องมือตัดสายเคเบิล และเชือกเหล็ก

■ Cable, steel ropes cutting tools คีมตัดสายไฟ

Cable 10 mm²~ 500 mm², round bars Ø5 mm ~ Ø9 mm, steel ropes Ø9 mm ~ Ø14 mm

- The operated handle is made from alloy-aluminum metal, treated by T6 heat; strong, durable and handy.
- The blade is forged by Chromium-Vanadium-steel, which is sharp to save labor on cutting.
- Ratchet cable cutter MS-325, MS-520 specialize in cutting Copper and Aluminum AWG 750 MCM, 1,000 MCM, (325 mm², 500 mm²)
- Couldn't cut steel rope and-or iron-bar materials; cable JIS cutters are suitable for IV. SV cables.



■ Wire Rope Cutter

Round bar wire rope cutter

- Specialize in cutting iron bars and steel ropes.
- The blade is forged by Tungsten steel.
- Type : MI-60, MI-200, MI-624

■ Selection Chart (applicable range)

Old number	Item number	Length		Weight kg	Copper cable		Price
		mm	in		DIN mm ²	AWG	
CC-22	ME-22	160	6 1/4"	0.193	25	# 4	600.-
CC-38	ME-38	210	8 1/4"	0.372	50	# 2	680.-
CC-60	ME-60	235	9 1/2"	0.510	60	# 1/0	740.-
CC-100	ME-100	320	12 5/8"	0.706	120	# 3/0	1,930.-
CC-250	ME-250	600	23 5/8"	1.634	300	500	3,000.-
CC-400	ME-400	690	26 3/4"	2.186	400	750	3,700.-
CC-500	ME-500	800	31 1/2"	2.960	630	1,000	4,330.-
CS-325	MS-325	255	9 1/2"	0.598	400	750	4,670.-
CS-520	MS-520	400	15 1/4"	1.534	630	1,000	12,840.-
-	MI-60	315	12 3/8"	0.734	round : ø5 mm / wire rope : ø5 mm		
-	MI-200	585	23"	1.644	round bar : ø9 mm / wire rope : ø10 mm		
-	MI-624	800	31 1/4"	5.142	steel wire : 1/2", ø12 mm		



HAND TYPE OF COMPRESSION TOOLS

คีมย้ำสายไฟ

Hand type of compression tools Capacity : 1.5 mm² ~ 150 mm² คีมย้ำสายไฟ

Hand pressed tool : Ratchet type and push type of machine motion

- Bare terminal, insulated terminal pressed; very tight and not easy to drop with good electric conducting.
 - Pressed terminal have point type and hexagonal type (hexagonal type press is the most affirmative now)
 - Wonderful coating and resistance rust treatment.
- excellent quality of chromium vanadium steel and cast iron for machine body. Manufacture by ISO 9002 precision cast mill.
- Strict heat treatment, computer control handle by ISO 9002.



Selection Chart (applicable range)

Old number	Item number	Length (mm)	Weight (kg)	Terminal sizes			Shape	Price
				AWG/MCM	JIS mm ²	DIN mm ²		
MH-02	MH-02	200	0.23	# 22-16, 16-14	1.25-2.0	1.2, 2.5	Point	900.-
CT-08	MH-08	265	0.42	# 12-10, 8, 6	1.25-8	1.5, 2.5, 6.0, 10	Point	930.-
CT-14	MH-14	295	0.5	# 22-16, 16-14, 12-10, 8, 6	2.0-14	2.5, 6.0, 10, 16	Point	1,220.-
CT-25	MH-22	350	0.74	# 22-10, 8, 6, 4	5.5-22	4-6, 10, 16, 25	Point	1,720.-
	MH-38H	365	0.82	# 8, 6, 2	14-38	16, 25, 35, 50	Hexagon	-
MH-123A	MH-123A	263	0.45	-	-	1.5-2.5, 6	Point	1,900.-
CK-05	MK-05	380	1.05	# 12-10, 8, 6, 4, 2	6-70	6, 10, 16, 25, 35, 50, 70	Hexagon	4,670.-
CK-06	MK-06	650	2.972	# 8, 6, 4, 2, 1/0, 2/0, 3/0	8-80	10, 16, 25, 35, 50, 70, 95, 120	Hexagon	6,120.-
CT-38	MT-38	545	2.5	# 8, 6, 2	8-38	10, 16, 25, 50	Point	2,950.-
CT-80	MT-80	670	4.94	# 8, 6, 4, 2, 1/0-3/0	8-80	16, 25, 35, 50-70, 95-120	Point	4,650.-
CT-100	MT-100	670	4.94	# 4, 2, 1/0, 4/0	22-100	25, 35, 50-70, 95, 120	Point	4,780.-
CK-07	MK-07	650	3.0	-	-	25, 35, 50, 70, 95, 120, 150	Hexagon	6,800.-



SWITCH AND DISCONNECT STICK

ไม้ชักฟิวส์

ไม้ชักฟิวส์ HIGH VOLTAGE INSULATED TUBE

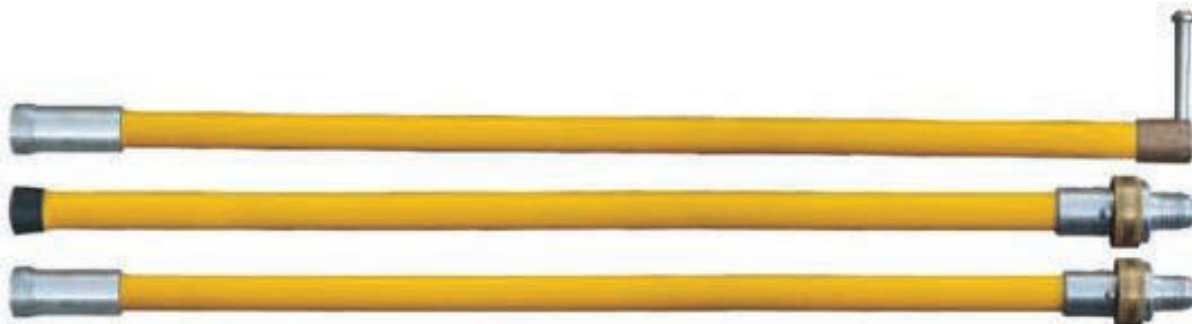

For operating and closing disconnect switches and cutouts, and also for installing and removing open-link fuse links.

- Test to CNS 9576.C4370. 90kV per feet for 5 minutes.
- Quick assemble, and easy to store these sticks in PVC bag.
- Stick is made of fiberglass, of diameter "1-1/4 and 1-1/2"
- Surface finish makes bright yellow color.
- Switch and disconnect head is made of high strength bronze.

Model	Pole dia. & length	No. piece	Price
HOTS-8	1-1/4" x 8' x 1	1	6,500.-
HOTS-10	1-1/4" x 10' x 1	1	7,000.-
HOTS-12	1-1/4" x 12' x 1	1	8,500.-
HOTS-16	1-1/4" x 8' x 1 + 1-1/2" x 8' x 1	2	13,100.-
HOTS-18	1-1/4" x 8' x 1 + 1-1/2" x 10' x 1	2	15,000.-
HOTS-20	1-1/4" x 10' x 1 + 1-1/2" x 10' x 1	2	16,500.-
HOTS-24	1-1/4" x 12' x 1 + 1-1/2" x 12' x 1	2	18,000.-
HOTS-24-1	1-1/4" x 8' x 1 + 1-1/2" x 8' x 2	3	25,500.-

HIGH VOLTAGE INSULATED TUBE



- Test to CNS 9576.C4370. 90kV per feet.
- Avoid any injury while working near the pole top, for safety purpose.
- Used for covering the cable line.
- Avoid any injury while working on the construction near the cable line, for safety purpose.

Model	Length	Diameter	Price
IT-25M	2.5 M	35 mm	1,600.-
IT-3M	3 M	35 mm	1,800.-

TEND

BANDEX

TAKAMURA

TEEFLEX

KENION

NISSEI

ROSI

APEKS

LKEW

TAC

MARLOW

HARU

WIND
SPEED

COMMAX

ADVANTE

UNIVERSAL
ADAPTER

ALION

EXOWELD

CONTROL
MAX

JKN

SYLVIA

WANG

MACCON

HARU® PULLING GRIPS

ตะกร้อดึงสายไฟ

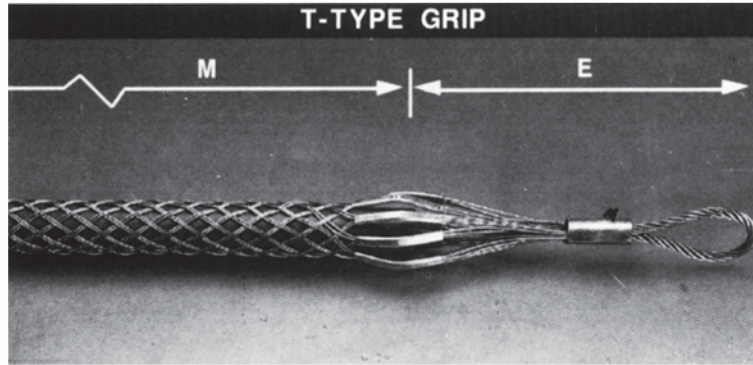

Model number	Cable diameter range inches	Approx breaking strength lbs	E (mm)	M (mm)	Price
Short					
TG-050-24	0.50 - 0.61	4,500	200	300	1,235.-
TG-062-24	0.62 - 0.74	5,600	200	500	1,575.-
TG-075-24	0.75 - 0.99	6,800	230	550	2,025.-
TG-100-24	1.00 - 1.49	9,600	230	600	2,420.-
TG-150-24	1.50 - 1.99	16,400	280	650	3,035.-
TG-200-24	2.00 - 2.49	18,500	300	700	3,375.-
TG-250-24	2.50 - 2.99	24,500	300	750	4,725.-
TG-300-24	3.00 - 3.49	24,500	350	800	5,400.-
TG-350-24	3.50 - 3.99	31,000	450	1,420	6,075.-
TG-350-36	3.50 - 3.99	31,000	350	1,050	6,075.-

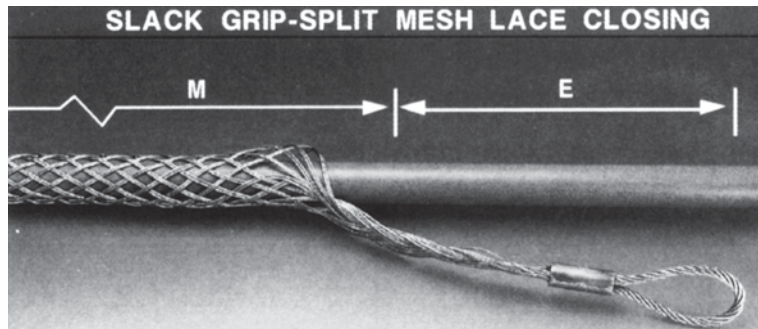

DOUBLE WEAVE					
Model number	Cable diameter range inches	Approx breaking strength lbs	E (mm)	M (mm)	Price
SG-075A	0.75 - 0.99	2,500	127	600	2,360.-
SG-100A	1.00 - 1.24	3,500	127	700	2,755.-
SG-125A	1.25 - 1.49	4,000	152	800	3,150.-
SG-150A	1.50 - 1.74	4,000	229	900	3,600.-
SG-200A	2.00 - 2.49	4,000	254	900	4,500.-
SG-250A	2.50 - 2.99	4,000	305	1,000	4,725.-
SG-350A	3.50 - 3.99	4,000	305	1,100	5,400.-

*ขอสงวนสิทธิ์ในการเปลี่ยนแปลงราคา

• Model 220-3

* For conduct and clean of the underground cable installation.



• ตัวนำดึงสายไฟ

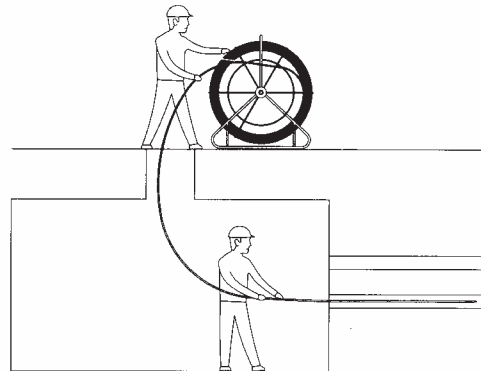

Item no.	Height	Max.	Storage	Price
220-3-200	0.60 m	6 mm	200 mtr	42,000.-

• Model 230-1



Item no.	Height	Max.	Storage	Price
230-1-50	1 m	11 mm	50 mtr	38,000.-
230-1-150	1 m	11 mm	150 mtr	64,500.-
230-1-200	1 m	11 mm	200 mtr	78,000.-
230-1-300	1 m	11 mm	300 mtr	120,000.-
230-1-450	1.2 m	11 mm	450 mtr	-
230-1-300-14	1.3 m	11 mm	300 mtr	-

TEND

BANDEX

TAKAMURA

TEEFLEX

KENION

NISSEI

ROSI

APEKS

LKEW

TAC

MARLOW

HARU

WIND
SPEED

COMMAX

ADVANTE

UNIVERSAL
ADAPTER

ALION

EXOWELD

CONTROL
MAX

JKN

SYLVIA

WANG

MACCON

HARU[®]**F.R.P. CONDUIT SNAKE**
ตัวนำดึงสายไฟ

• Model 220-1

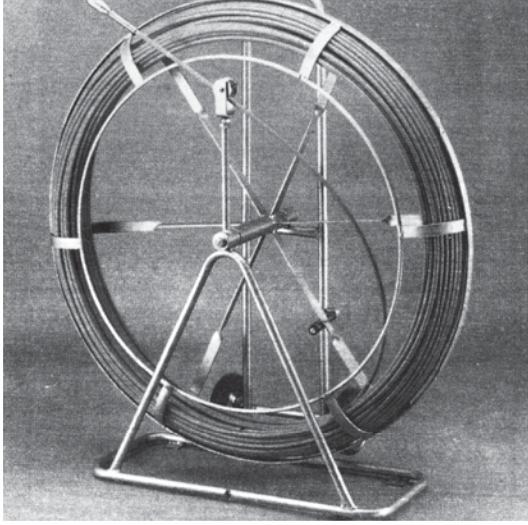

• ตัวนำดึงสายไฟ

Reel : Hight Ø1 M Weight 19 Kg.
Hight Ø1.2 M Weight 22 Kg.

Length : 50m, 100m, 120m, 150m, 200m, 240m,
250m, 300m, or any length

Item no.	Diameter	Length	Price
FRP50	11 M/M	50M	38,000.-
FRP100	11 M/M	100M	52,000.-
FRP120	11 M/M	120M	57,000.-
FRP150	11 M/M	150M	64,500.-
FRP200	11 M/M	200M	78,000.-

CABLE PULLING

■ ตัวนำดึงสายไฟในท่อร้อยสาย



- ใช้งานง่าย ไม่เกิดสนิมและทนแรงดึงได้ถึง 125 กิโลกรัม
- ปลอดภัย ไม่เป็นสื่อนำไฟฟ้า
- มีหัวตัวนำทางซึ่งเป็นอิสระหมุนได้รอบตัวทำให้ร้อยสายไฟทำได้รวดเร็ว และคล่องกว่า

Item no.	Diameter	Length	Price
NF-15	4.5 M/M	15 M	780.-
NF-30	4.5 M/M	30 M	1,435.-
NF-50	4.5 M/M	50 M	2,215.-

■ SURELY



- ใช้งานง่าย ม้วนเก็บง่ายไม่เกิดสนิม
- ประกอบด้วยลวดสปริง 3 เส้น ทุกเส้นหุ้มด้วย PVC ทนแรงดึงได้ถึง 400 กิโลกรัม
- มีหัวตัวนำทำให้ร้อยสายไฟได้อย่างรวดเร็ว

Item no.	Diameter	Length	Price
LK-W15	6 M/M	15 M	3,680.-
LK-W30	6 M/M	30 M	5,900.-
LK-W50	6 M/M	50 M	7,300.-

*ขอสงวนสิทธิ์ในการเปลี่ยนแปลงราคา

HARU® GRIP

กริปจับสายไฟ

SD WIRE GRIP

Also for Copper Messenger Wire



Model	Conductor dia.(mm)	Safe load	Weight kg	Price
SD-1000C	2.6-15	1 TON	0.6	3,150.-

2 TON MIGHTY GRIP

Also for Copper Messenger Wire



Model	Conductor dia.(mm)	Safe load	Weight kg	Price
S-2000C	4 - 22	2 TON	1.3	4,600.-

3 TON-L-GRIP

For Copper cable, covered conductor and messenger wire.



Model	Conductor dia.(mm)	Safe load	Weight kg	Price
S-3000CL	16 - 32	3 TON	2.8	9,000.-

PAT NGK GRIPS



Model	Min-Max (mm)	Max. Safe Load lbs	Weight (kg)	Price
1656-20	5.08 - 10.16	4500	1.36	4,725.-
1656-30	7.87 - 13.46	4500	1.7	5,060.-
1656-40	13.46 - 18.8	8000	3.4	5,850.-
1656-50	18.04 - 21.83	8000	3.4	6,750.-

TEND

BANDEX

TAKAMURA

TEEFLEX

KENION

NISSEI

ROSI

APEKS

LKEW

TAC

MARLOW

HARU

WIND SPEED

COMMAX

ADVANTE

UNIVERSAL ADAPTER

ALION

EXOWELD

CONTROL MAX

JKN

SYLVIA

WANG

MACCON

TEND

BANDEX

TAKAMURA

TEEFLEX

KENION

NISSEI

ROSI

APEKS

LKEW

TAC

MARLOW

HARU

WIND
SPEED

COMMAX

ADVANTE

UNIVERSAL
ADAPTER

ALION

EXOWELD

CONTROL
MAX

JKN

SYLVIA

WANG

MACCON

HARU® PULLER พูลเลอร์

MODEL 1040



RATCHET PULLER SET 1 TON PULLER

Capacity	Weight (kg)	Price
1 TON	5.2	9,450.-

MODEL 1506



RATCHET PULLER SET 1.5 TON PULLER

Capacity	Weight (kg)	Price
1.5 TON	6.2	10,125.-

JAW & JAW



Model	Working load limit (kg)	Weight (kg)	Dia (mm)	Price
HGS-3000	1000	0.25	24	3,200.-
HGS-8000	4000	0.9	38	4,725.-

*ขอสงวนสิทธิ์ในการเปลี่ยนแปลงราคา



SAFETY BELT

เข็มขัดนิรภัย

MODEL HC-12 (For single suspension only)

Price 980.-



Working Limit 100 Kg.
EN Standard Safe Load

Nylon Life Line

dia. 13 mm, length 1,500 mm

Nylon Body Belt [twill fabric]

width 50 mm. length 1,200 mm

weight approx. 1.11 kgs.

Safety belt with 12 mm dia. Life line is also available.

MODEL HC-27 (For both U-shaped and single-line suspension)

Price 3,100.-



Working Limit 100 Kg.
EN Standard Safe Load

Nylon Life Line

dia. 16 mm, length 2,200 mm

Nylon Inner Belt

width 75 mm. length 700 mm

Nylon Outlet Belt

width 45 mm. length 1,200 mm

weight approx. 2,000 g

MODEL HC-113 (For both U-shaped and single-line suspension)

Price 4,740.-



Working Limit 100 Kg.
EN Standard Safe Load

Nylon life Line

dia. 16 mm, length 2,200 mm

Nylon Inner Belt

width 90 mm. length 700 mm

Nylon Outlet Belt

width 45 mm. length 1,200 mm

weight approx. 2,600 g

TEND

BANDEX

TAKAMURA

TEEFLEX

KENION

NISSEI

ROSI

APEKS

LKEW

TAC

MARLOW

HARU

WIND
SPEED

COMMAX

ADVANTE

UNIVERSAL
ADAPTER

ALION

EXOWELD

CONTROL
MAX

JKN

SYLVIA

WANG

MACCON

TEND

BANDEX

TAKAMURA

TEEFLEX

KENION

NISSEI

ROSI

APEKS

LKEW

TAC

MARLOW

HARU

WIND
SPEED

COMMAX

ADVANTE

UNIVERSAL
ADAPTER

ALION

EXOWELD

CONTROL
MAX

JKN

SYLVIA

WANG

MACCON

HARU[®]**SAFETY HARNESS / LANYARD**

เข็มขัดแบบเต็มตัว / เชือกกันตก

*** Safety harness and lanyard are strongly recommend when working at height above 2 m.****MODEL TH-201****Working Limit 100 Kg.
EN Standard Safe Load****MODEL HC-102****Working Limit 100 Kg.
EN Standard Safe Load**

Model	Front	D Ring back	Side	Strap buckles			Special feature	Price
				Chest	Shoukder	Leg		
TH-201	N	Y	N	Y	Y	Y	Simple: Light Weight, Easy to wear.	1,650.-
HC-102	N	Y	Y	N	Y	Y	Standard: D Ring on waist for snap hook.	1,850.-

LANYARD*** Safety harness and lanyard are strongly recommend when working at height above 2 m.****MODEL R150BC**

Large Snap Hook + Karabiner		Price
Model	Lanyard specification	
R150BC	14 mm Rope x 1.5 mtr	1,100.-

MODEL LA15

Large Snap Hook + Karabiner		Price
Model	Lanyard specification	
LA15	Cushion Lanyard x 1.5 mtr	1,300.-

MODEL DLA15/DLA20

Large Snap Hook x2 + Karabiner		Price
Model	Lanyard specification	
DLA15	Cushion Lanyard x 1.5mtr	2,480.-
DLA20	Cushion Lanyard x 2.0mtr	2,700.-

*ขอสงวนสิทธิ์ในการเปลี่ยนแปลงราคา



RETRACTABLE LIFELINE รอกนิรภัย

* The retract system helps individual protecting against falls work.

MODEL HB-10



MODEL HB-15



MODEL HB-20



ANCHORAGE ROPE

Connect snap hook to the thimble and insert in the karabiner.



CONDUIT ROPE

When lifeline is fixed on the top, the conduit rope is used to bring down the cable for the user to connect the snap hook on the D-Ring of safety harness.



10m, 15m, 20m

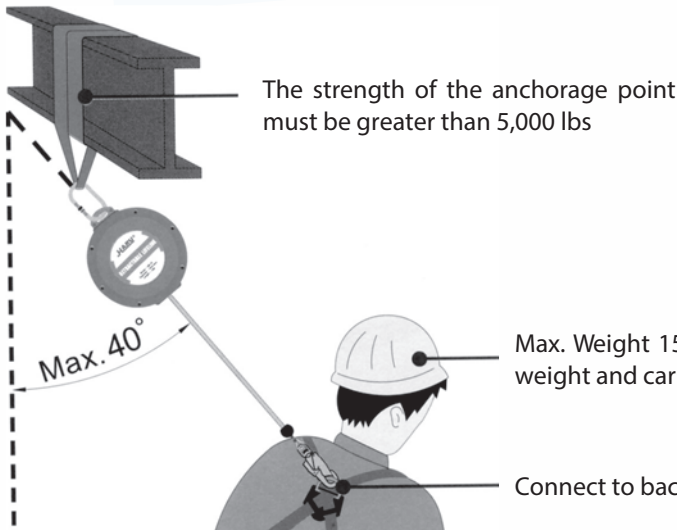

** HB-10 used galvanized wire, HB-10(S) used stainless cable.

Model	Cable	Length	Wire breaking	Max. stop distance	Weight	Price.
HB-10 (S)	4 mm	10 m	1,250 kg up	1.5 m	4.6 kg	18,000.-
HB-15 (S)	4 mm	15 m	1,250 kg up	1.5 m	6.6 kg	28,000.-
HB-20 (S)	4 mm	20 m	1,250 kg up	1.5 m	8.6 kg	38,000.-

TEND

BANDEX

TAKAMURA

TEEFLEX

KENION

NISSEI

ROSI

APEKS

LKEW

TAC

MARLOW

HARU

WIND
SPEED

COMMAX

ADVANTE

UNIVERSAL
ADAPTER

ALION

EXOWELD

CONTROL
MAX

JKN

SYLVIA

WANG

MACCON

HARU® RETRACTABLE LIFELINE

รอกนิรภัย

MODEL HB-6N



CONDUIT ROPE

When lifeline is fixed on the top, the conduit rope is used to bring down the cable for the user to connect the snap hook on the D-Ring of safety harness.

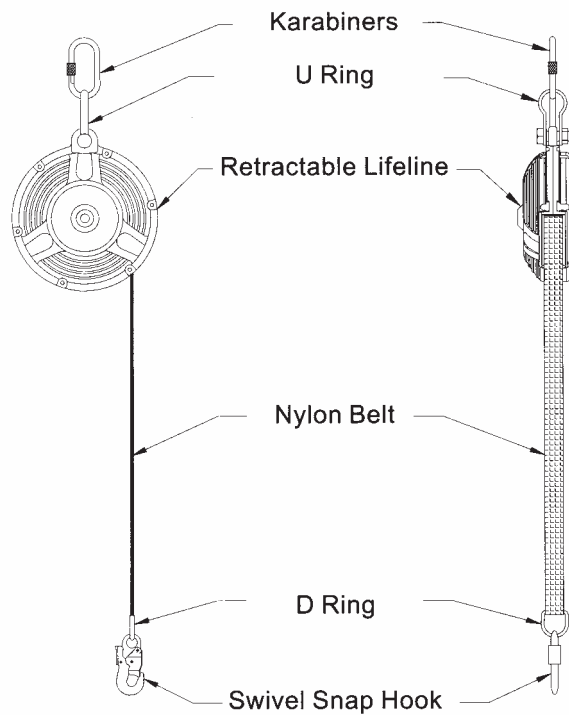
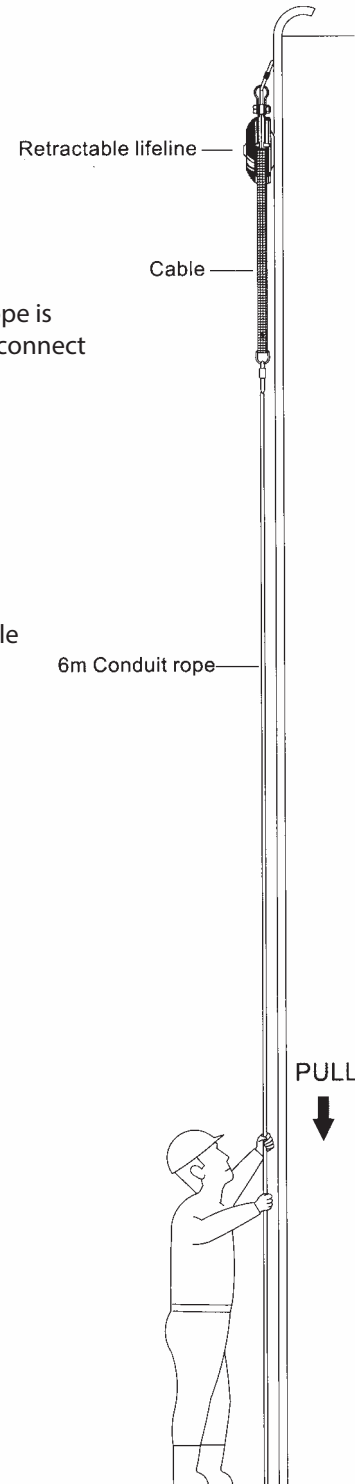

Model	Cable	Length	Wire breaking	Max. stop distance	Weight	Price
HB-6N	25 mm	6 m	1,250 kg up	1.2 m	1.6 kg	17,000.-

*ขอสงวนสิทธิ์ในการเปลี่ยนแปลงราคา



CARBIDE TIPPED HOLE SAW

ดอกเจาะสำหรับเจาะสแตนเลส

FS-22

■ FS-22 Standard model

Size ranges : DIA. 15 mm - 100 mm



● Size ranges

Ø15 mm - Ø100 mm (with variation of 1 mm)

● Special features

For tough drilling on 5 mm thick

● Stainless steel sheet. Low wear-off main applications

For drill operation on stainless steel sheet or square wares, cast iron. Iron plates and FRP formed products

● Application

Stainless steel sheet, hollow-wire, pipe, square pipe etc. Electric control box, auto body, cast iron, FRP (fiberglass reinforced plastic). Aluminium window/ door frames, water tank made of stainless steel. Ship-byilding industry, plumbing industry etc.

■ Please adopt lower rpm for pipe and higher rpm for sheet

Dia. mm.	Stainless steel	Unhardened steel	Iron sheet
15 - 19	800 - 1000	450 - 800	1500 - 2000
20 - 29	480 - 800	315 - 420	1000 - 1400
30 - 39	320 - 530	250 - 350	650 - 950
40 - 49	240 - 400	195 - 250	470 - 720
50 - 59	200 - 320	160 - 195	380 - 570
60 - 69	150 - 250	120 - 160	300 - 500
70 - 79	100 - 150	100 - 120	200 - 350
over 80	under 100	under 100	under 200

■ ดอกเจาะสำหรับเจาะสแตนเลส

Size mm. ขนาด (มม.)	Size In. ขนาด (นิ้ว)	Size for conduit In. ใช้สำหรับท่อ (นิ้ว)	Price ราคา
16	5 / 8	-	725.-
19	3 / 4	-	725.-
20	-	-	760.-
22	7 / 8	1 / 2	760.-
25	1	-	760.-
28	-	3 / 4	875.-
30	1 1/8	-	875.-
32	1 1/4	-	970.-
33	-	-	970.-
34	1 3/8	1	970.-
35	1 3/8	1	970.-
38	1 1/2	-	1,150.-
41	1 5/8	-	1,340.-
43	1 3/4	1 1/4	1,460.-
44	-	-	1,460.-
48	-	1 1/2	1,770.-
49	-	1 1/2	1,770.-
50	-	1 1/2	1,770.-
51	2	-	1,875.-
60	-	2	2,300.-
61	-	-	2,300.-
64	2 1/2	-	2,300.-
70	-	-	2,550.-
73	-	2 1/2	3,085.-
76	3	-	3,460.-
89	3 1/2	3	4,195.-

TEND

BANDEX

TAKAMURA

TEEFLEX

KENION

NISSEI

ROSI

APEKS

LKEW

TAC

MARLOW

ADVANTE

UNIVERSAL
ADAPTER

ALION

EXOWELD

CONTROL
MAX

JKN

SYLVIA

WANG

MACCON



Wind Speed

H.S.S. HOLE SAW

ดอกเจาะสำหรับเจาะเหล็ก

- High speed steel hole saw
HS-16 Standard model
Size ranges : DIA. 16 mm - 76 mm



- Material
High speed steel (SKH51)
- Size ranges
Ø16 mm (5/8") - Ø76 mm (3") Diameter
- Applications
For tough drilling on 1.6 mm thick iron plates

User

- (A) Electric work :
 - Pipeing
 - Refrigeration machines
- (B) Iron work :
 - Sheet metal work
 - Drill hole installation

Special features

- (A) Sharper teeth tip for easier cutting.
- (B) Longer product life, teeth stay sharp longer.
- (C) Better chip clearance.
- (D) For precision hole drilling

Packing

Each packed in a PVC box.
Fixed with arbor and HSS pilot drill.

ดอกเจาะสำหรับเจาะเหล็ก

Size mm. ขนาด (มม.)	Size In. ขนาด (นิ้ว)	Size for conduit In. ใช้สำหรับท่อ (นิ้ว)	Price ราคา
13	1 / 2	-	385.-
16	5 / 8	-	415.-
19	3 / 4	-	425.-
20	-	-	440.-
22	7 / 8	1 / 2	470.-
25	1	-	545.-
26	-	-	545.-
28	-	3 / 4	575.-
30	1 1/8	-	600.-
31	-	-	615.-
32	1 1/4	-	640.-
33	-	-	695.-
34	1 3/8	1	750.-
35	1 3/8	1	775.-
38	1 1/2	-	990.-
40	-	-	1,100.-
41	1 5/8	-	1,100.-
43	1 3/4	1 1/4	1,135.-
45	-	-	1,255.-
48	-	1 1/2	1,375.-
50	-	1 1/2	1,465.-
51	2	-	1,535.-
54	-	-	1,575.-
60	-	2	1,640.-
61	-	-	1,670.-
64	2 1/2	-	1,760.-
70	-	-	2,535.-
73	-	2 1/2	2,800.-
76	3	-	3,070.-

*ขอสงวนสิทธิ์ในการเปลี่ยนแปลงราคา

MAXIMUM CURRENT FOR PVC INSULATED WIRE TYPE-THW / ตารางเทียบสาย TW

Size	Cable construction		Ampacity		Size	Cable construction		Ampacity	
	AWG	MM	SQMM	Free air		In conduit	AWG	MM	SQMM
14	1/1.63	2.08	16	12	2/0	19/2.13	67.67	186	120
12	1/2.1	3.46	20	16	3/0	19/2.40	85.91	220	135
10	1/2.59	5.27	30	24	4/0	19/2.68	107.13	250	158
8	1/3.25	8.59	42	32	250	37/2.09	126.87	274	1745
14	7/0.61	2.04	16	12	300	37/2.30	153.65	306	194
12	7/0.81	3.61	20	16	350	37/2.50	181.53	340	213
10	7/0.98	5.28	30	24	400	37/2.65	203.97	380	224
8	7/1.25	8.59	42	32	500	37/2.95	252.76	416	258
6	7/1.55	13.20	60	44	600	61/2.52	304.09	462	286
4	7/1.97	21.33	84	59	700	61/2.72	354.27	504	310
3	7/2.20	26.60	98	66	750	61/2.82	380.80	528	322
2	7/2.24	33.52	114	78	800	61/2.91	405.49	546	330
1	19/1.69	42.60	134	88	900	61/3.09	457.21	590	350
1/0	19/1.89	53.28	160	105	1000	61/3.25	505.79	626	364

MAXIMUM CURRENT FOR PVC INSULATED WIRE TYPE-THW / ตารางเทียบสาย TW

Size	Cable construction		Ampacity		Size	Cable construction		Ampacity	
	AWG	MM	SQMM	Free air		In conduit	AWG	MM	SQMM
14	1/1.63	2.08	16	11	2/0	19/2.13(10.7)	67.67	237	156
12	1/2.10	3.46	26	18	3/0	19/2.40(12.0)	85.91	275	179
10	1/2.59	5.27	36	25	4/0	19/2.68(13.4)	107.13	300	205
8	1/3.25	8.59	58	40	250	37/2.09(14.6)	126.87	325	225
14	7/0.61	2.04	17	11	300	37/2.30(16.1)	153.65	363	233
12	7/0.81	3.61	26	18	350	37/2.50(17.5)	181.53	410	255
10	7/0.98	5.28	36	25	400	37/2.65(18.8)	203.97	450	270
8	7/1.25	8.59	58	40	500	37/2.95(20.7)	252.76	495	305
6	7/1.55	13.2	80	55	600	61/2.52(22.7)	304.09	558	340
4	7/1.97	21.33	110	75	700	61/2.72(24.5)	354.27	606	370
3	7/2.20	26.60	126	86	750	61/2.82(25.4)	380.80	632	383
2	7/2.24	33.52	147	102	800	61/2.91(26.2)	405.49	655	395
1	19/1.69	42.60	170	115	900	61/3.09(27.8)	457.21	702	417
1/0	19/1.89	53.28	200	133	1000	61/3.25(29.3)	505.79	754	438

MAXIMUM NUMBER OF CONDUCTORS IN CONDUIT OR TUBING / ตารางเทียบสายร้อยในท่อคอนดัก

AWG	1/2"	3/4"	1"	1 1/4"	1 1/2"	2"	2 1/2"	3"	AWG	1/2"	3/4"	1"	1 1/4"	1 1/2"	2"	2 1/2"	3"
18	13	24	38	68	93	152	-	-	1	-	1	1	2	4	6	9	14
16	11	19	31	55	75	123	176	270	1/0	-	1	1	2	3	5	8	12
14	5	10	16	29	40	65	93	143	2/0	-	1	1	1	3	4	7	10
12	4	8	13	24	32	53	76	117	3/0	-	-	1	1	2	4	5	9
10	1	6	11	19	26	43	61	95	4/0	-	-	1	1	1	3	5	7
8	1	4	6	11	15	25	36	56	250	-	-	-	1	1	2	4	6
6	1	2	4	7	10	16	23	36	300	-	-	-	1	1	2	3	5
4	1	1	3	5	7	12	17	27	350	-	-	-	1	1	1	3	4
3	1	1	2	4	6	10	16	23	400	-	-	-	1	1	1	2	4
2	1	1	1	4	5	9	13	20	500	-	-	-	-	1	1	1	3

ตารางเทียบสำหรับมอเตอร์สตาร์ทเตอร์ ขนาด 3 สาย
H.TABLE FOR DIMENSIONS FOR MOTOR STARTERS

The figures are based on normal 3 - phase motor for a.c. at 50 c. p.s. 1400-1450 r.p.m.

อัตราของมอเตอร์ใน HP โวลท์ทำงาน				อัตราของ มอเตอร์ สตาร์ทเตอร์ A แอมป์	ปรับระยะ รีเลย์ A แอมป์	อัตราการใช้ฟิวส์ ขนาดสูงสุด A แอมป์	การใช้สาย ไฟฟ้าขนาด ต่ำสุดชนิด mm ²
220 V		380 V					
HP แรงม้า	อัตราการทำงานเต็มที่ ของกระแสไฟ AMP	HP แรงม้า	อัตราการทำงานเต็มที่ ของกระแสไฟ AMP				
		0.05		15	0.15 ~ 0.25	1	1.5
0.05		0.1		15	0.25 ~ 0.4	2	1.5
		0.15		15	0.4 ~ 0.65	4	1.5
0.1		0.2		15	0 ~ 0.65	4	1.5
0.15		0.25	0.6	15	0.6 ~ 1.0	6	1.5
0.25	1.1	0.5	1.0	15	1.0 ~ 1.6	6	1.5
		0.75	1.5	15	1.5 ~ 2.5	6	1.5
0.5	1.8	1.0	1.9	15	2.5 ~ 4	15(10)	1.5
0.75	2.5	1.5	2.6	15	2.5 ~ 4	25(15)	1.5
1.0	3.2	2	3.4	15	4 ~ 6.5	25(15)	1.5
1.5	4.4	2.5	4.2	15	4 ~ 6.5	25(20)	1.5
2.0	5.8	3	4.9	15	6 ~ 10	25(20)	1.5
2.5	7.3	4	6.3	15	6 ~ 10	35(25)	1.5
3	8.4	5	7.8	15	9 ~ 14	35(25)	1.5
4	11	6	9.3	15	9 ~ 14	35	1.5
5	13.5	7.5	11.5	15	13 ~ 20	35	1.5
		10	15	25	16 ~ 25	60	2.5
7.5	19.5	15	22	25	20 ~ 31	60	4
10	26	20	29	60	28 ~ 43	100	6
15	39	25	36	60	40 ~ 60	125	10
20	51	30	42	60	40 ~ 60	160	16
		35	50	60	40 ~ 60	160	16
		40	56	60	50 ~ 75	160	16
25	63	50	69	100	70 ~ 100	200	16
25	91	60	83	100	84 ~ 120	200	25
40	100	75	104	200	105 ~ 150	400	35
50	125	100	136	200	140 ~ 200	500	50
75	184	125	167	200	175 ~ 250	500	95
		150	200	350	175 ~ 250	600	120
100	245	175	235	350	175 ~ 300	600	120
120	295	200	268	350	280 ~ 400	850	150
150	370	250	335	600	350 ~ 500	850	240
175	425	300	400	600	350 ~ 500	1000	400
200	475	350	470	600	350 ~ 500	1000	400
225	540	400	535	600	420 ~ 600	1000	500