



เหมาะกับการใช้งาน Outdoor



IP65
ระดับการป้องกัน



General Specifications

- Reference standard : EN/IEC 60051
- Case-dimensions : DIN 43700
- Scales and pointer : DIN 43802
- Magnetic influence : DIN 43780
- Safety : IEC 1010-1
- Housing : Self-extinguishing polymer PC according to UL94V-0
- Glass : Anti-dazzling
- Accuracy class : 1.5, 2.5
- Operating frequency : 45-65Hz
- Dielectric test voltage : 2KV/ 50Hz/ 1minute
- Overload AC voltage : x1.2 continuous(x2 for 5 seconds)
- Overload AC Current : x1.2 continuous(x10 for 5 seconds)
- Power consumption
- Voltage from 1 to 4VA : 1.8VA for 250V, 3.3VA for 500V
- Current from 0.3 to 1.5VA : 0.7VA for 1A, 1.2VA for 5A
- Reference temperature : 23°C ± 2°C
- Operating temperature : -25°C to 65°C
- Storage temperature : -35°C to 70°C
- Relative humidity : ≤85%

CONNECTION DIAGRAM

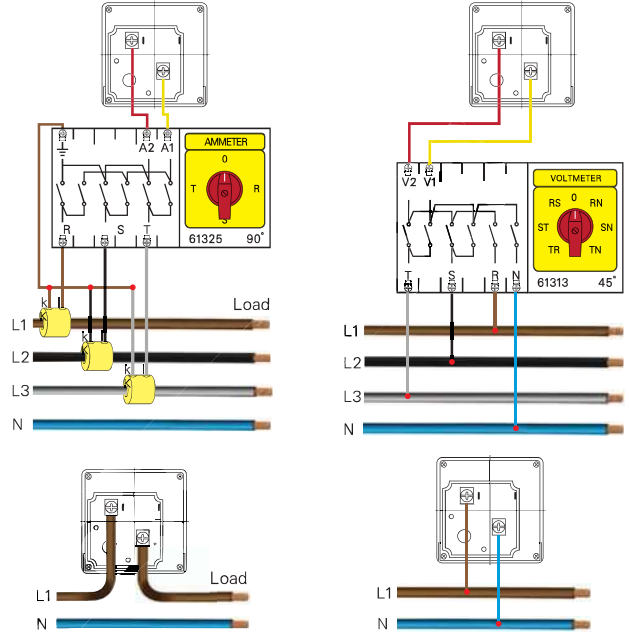

HL-96A



HL-96V



ตัวล๊อค
(แบบพิเศษ)

DIMENSION

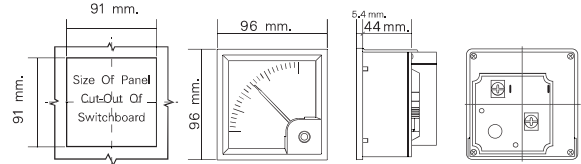

Voltmeter & Ammeter HL-96 Series Moving Iron Type

IP65

รุ่น (Model)	Accuracy class	Class protection Housing/Terminal	Connection	Measuring range				ราคา(บาท)
HL-96A	1.5	IP65/IP20	Through current transformers (5A)	5/5A	10/5A	15/5A	20/5A	760.-
				30/5A	40/5A	50/5A	60/5A	
				80/5A	100/5A	125/5A	150/5A	
				160/5A	200/5A	250/5A	300/5A	
				400/5A	500/5A	600/5A	800/5A	
				1000/5A	1200/5A	1250/5A	1500/5A	
				1600/5A	2000/5A	2500/5A	3000/5A	
				4000/5A	5000/5A			
HL-96A	1.5 2.5	IP65/IP20	Direct	5A	10A	15A	20A	760.-
				30A	40A	50A		
				60A	100A			
HL-96V	1.5	IP65/IP20	LN , LL	300V	500V			790.-

* ราคาสินค้าไม่รวมภาษีมูลค่าเพิ่มและราคาอาจเปลี่ยนแปลงได้โดยไม่ต้องแจ้งให้ทราบล่วงหน้า *



เหมาะกับงาน Outdoor



IP65
ระดับการป้องกัน



HL-96FP

CONNECTION DIAGRAM

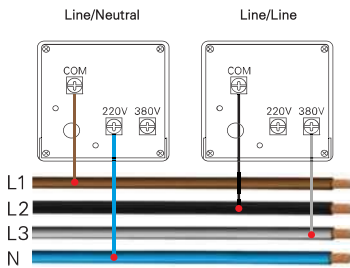

HL-96P



HL-96KW

CONNECTION DIAGRAMS
ACTIVE POWER METER
3P 4W UNBALANCED LOAD WITH
STAR CONNECTED C.T.s

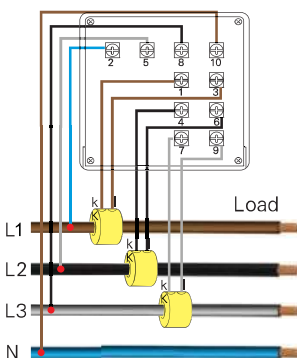

มิเตอร์วัดความถี่ (Frequency Meter) Moving Coil Type

IP65▲

รุ่น (Model)	Type	Accuracy Class	Input Voltage	Measuring Range	ราคา(บาท)
HL-96FP	แบบเข็ม	1.5	220V, 380V	45...55 Hz, 45...65 Hz	1,200.-

เพาเวอร์ แฟคเตอร์ (Power Factor Meter) Moving Coil Type

IP65▲

รุ่น (Model)	Input Voltage	Accuracy Class	Active	Input Voltage	Measuring Range	ราคา(บาท)
HL-96P	220V	2.5	1P	5A	Cap 0.5...1...0.5 IND	2,200.-
HL-96P	380V	2.5	1P	5A	Cap 0.5...1...0.5 IND	2,200.-

DIMENSION

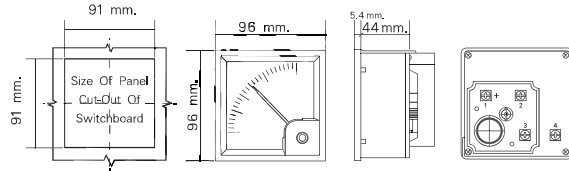

CONNECTION DIAGRAM



ตัวล็อก
(แบบพิเศษ)

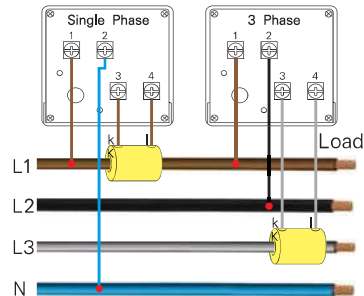

กิโลวัตต์มิเตอร์ (Active Power Meter) Moving Coil Type

IP65▲▲

รุ่น (Model)	Measuring Range			ราคา(บาท)
HL-96KW	0-3 KW (CT 5/5A)	0-60 KW (CT 100/5A)	0-600 KW (CT 1000/5A)	3,300.-
	0-6 KW (CT 10/5A)	0-100 KW (CT 150/5A)	0-800 KW (CT 1200/5A)	
	0-10 KW (CT 15/5A)	0-150 KW (CT 200/5A)	0-1 MW (CT 1500/5A)	
	0-15 KW (CT 20/5A)	0-160 KW (CT 250/5A)	0-1.2 MW (CT 1600/5A)	
	0-20 KW (CT 30/5A)	0-200 KW (CT 300/5A)	0-1.5 MW (CT 2000/5A)	
	0-25 KW (CT 40/5A)	0-250 KW (CT 400/5A)	0-1.6 MW (CT 2500/5A)	
	0-30 KW (CT 50/5A)	0-300 KW (CT 500/5A)	0-2 MW (CT 3000/5A)	
	0-40 KW (CT 60/5A)	0-400 KW (CT 600/5A)	0-2.5 MW (CT 4000/5A)	
	0-50 KW (CT 80/5A)	0-500 KW (CT 800/5A)	0-3 MW (CT 5000/5A)	

DIMENSION

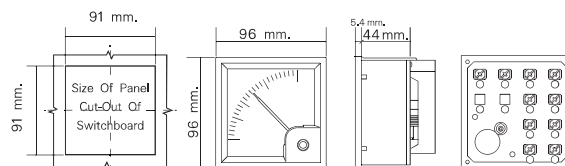

* ราคาสินค้าไม่รวมภาษีมูลค่าเพิ่มและราคาอาจเปลี่ยนแปลงได้โดยไม่ต้องแจ้งให้ทราบล่วงหน้า *



SD-96 Series Moving Iron Type



SD-96V

CONNECTION DIAGRAM

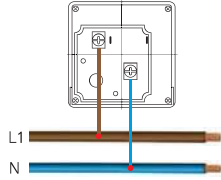

SD-96V

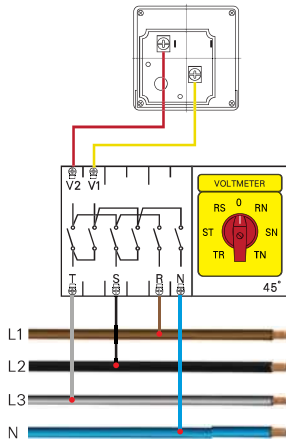

Specifications

- Reference standard : EN/IEC 60051
- Case-dimensions : DIN 43700
- Scales and pointer : DIN 43802
- Magnetic influence : DIN 43780
- Safety : IEC 1010-1
- Housing : Self-extinguishing polymer ABS according to UL94V-0
- Protection for housing : IP40 as standard
- Protection for terminals : IP00 without back cover
IP20 with back cover
- Accuracy class : 1.5, 2.5
- Operating frequency : 45~65Hz
- Dielectric test voltage : 2KV/ 50Hz/ 1minute
- Overload AC voltage : x1.2 continuous(x2 for 5 seconds)
- AC Current : x1.2 continuous(x10 for 5 seconds)
- Power consumption
- Voltage : 1.8VA for 250V, 3.3VA for 500V
- Current : 0.7VA for 1A, 1.2VA for 5A
- Reference temperature : 23°C ± 2°C
- Operating temperature : -25°C to 40°C
- Storage temperature : -40°C to 70°C
- Relative humidity : ≤85%

โวลท์มิเตอร์ (VoltMeter) ~1.5

รุ่น (Model)	Connection	Measuring Range	ราคา (บาท)
SD-96V	Line/Neutral Line/Line	0-300V 0-500V	360.-



SD-96A

CONNECTION DIAGRAM

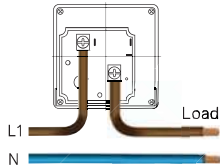

SD-96A

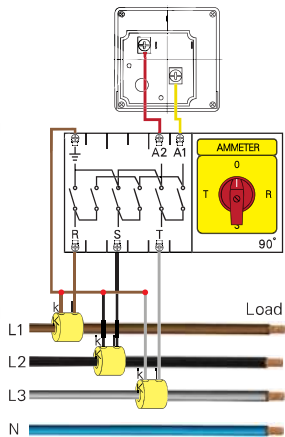

แอมป์มิเตอร์ (Ammeter) ~1.5,2.5

รุ่น (Model)	Connection	Measuring Range	ราคา (บาท)
SD-96A	Direct Connect (ต่อตรง)	5A 10A 15A	320.-
		20A 30A 50A	
		60A 100A	
SD-96A	Through current transformers (5A)	5/5A 10/5A 15/5A	320.-
		20/5A 30/5A 40/5A	
		50/5A 60/5A 80/5A	
		100/5A 125/5A 150/5A	
		160/5A 200/5A 250/5A	
		300/5A 400/5A 500/5A	
		600/5A 800/5A 1000/5A	
		1200/5A 1250/5A 1500/5A	
		1600/5A 2000/5A 2500/5A	
		3000/5A 4000/5A 5000/5A	

DIMENSION

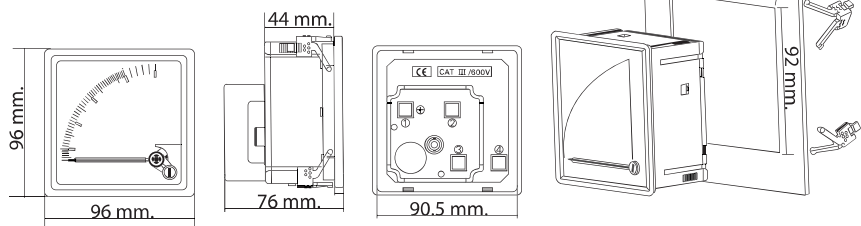

* ราคาสินค้าไม่รวมภาษีมูลค่าเพิ่มและราคาอาจเปลี่ยนแปลงได้โดยไม่ต้องแจ้งให้ทราบล่วงหน้า *

SD-96 Series
Moving Coil Type



SD-96FP (แบบเข็ม)



SD-96FR (แบบสั่น)

CONNECTION DIAGRAM

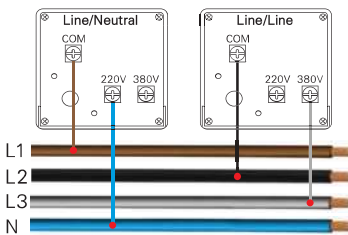

มิเตอร์วัดความถี่ (Frequency Meter) ~1.5

รุ่น (Model)	Type	Accuracy Class	Connection Input Voltage	Measuring Range	ราคา (บาท)
SD-96FP	แบบเข็ม	1.5	220V, 380V	45...55 Hz 45...65 Hz	1,100.-
SD-96FR	แบบสั่น	1.5	220V, 380V	45...55 Hz	980.-

เพาเวอร์ แฟคเตอร์ มิเตอร์ (Power Factor Meter) ~2.5

รุ่น (Model)	Phase	Accuracy Class	Connection Input Voltage	Measuring Range	ราคา (บาท)
SD-96P	1P	2.5	220V	Cap 0.5...1...0.5 IND	1,800.-
SD-96P	3P	2.5	380V	Cap 0.5...1...0.5 IND	1,800.-



SD-96P

CONNECTION DIAGRAM

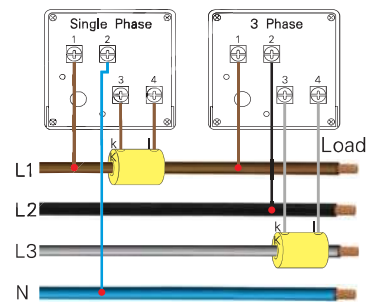

DIMENSION

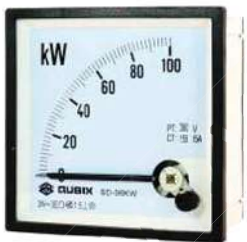
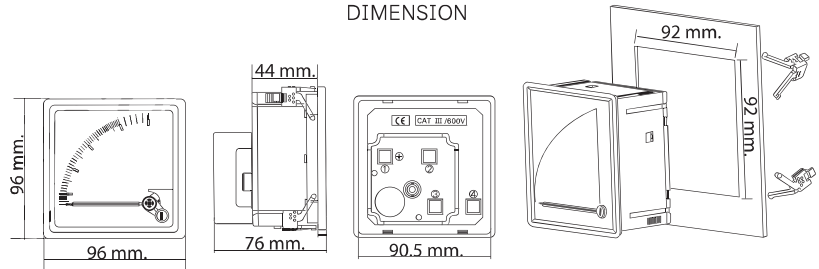

SD-96KW

CONNECTION DIAGRAMS
ACTIVE POWER METER
3P 4W UNBALANCED LOAD WITH
STAR CONNECTED C.T.s

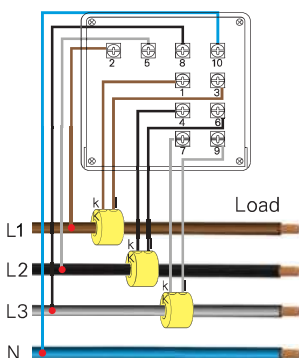

กิโลวัตต์มิเตอร์ (Kilowatt Meter) ~1.5

รุ่น (Model)	Measuring Range	ราคา (บาท)
SD-96KW	0-3KW (CT5/5A) 0-60KW (CT100/5A) 0-600KW (CT1000/5A)	2,500.-
	0-6KW (CT10/5A) 0-100KW (CT150/5A) 0-800KW (CT1200/5A)	
	0-10KW (CT15/5A) 0-150KW (CT200/5A) 0-1MW (CT1500/5A)	
	0-15KW (CT20/5A) 0-160KW (CT250/5A) 0-1.2MW (CT1600/5A)	
	0-20KW (CT30/5A) 0-200KW (CT300/5A) 0-1.5MW (CT2000/5A)	
	0-25KW (CT40/5A) 0-250KW (CT400/5A) 0-1.6MW (CT2500/5A)	
	0-30KW (CT50/5A) 0-300KW (CT500/5A) 0-2MW (CT3000/5A)	
	0-40KW (CT60/5A) 0-400KW (CT600/5A) 0-2.5MW (CT4000/5A)	
	0-50KW (CT80/5A) 0-500KW (CT800/5A) 0-3MW (CT5000/5A)	

DIMENSION

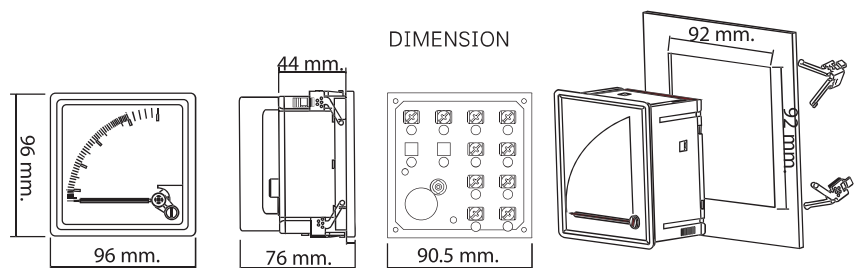

* ราคาสินค้าไม่รวมภาษีมูลค่าเพิ่มและราคาอาจเปลี่ยนแปลงได้โดยไม่ต้องแจ้งให้ทราบล่วงหน้า *



SD-50V

CONNECTION DIAGRAMS

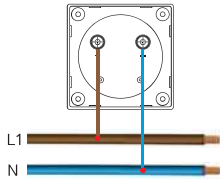

SD-60V

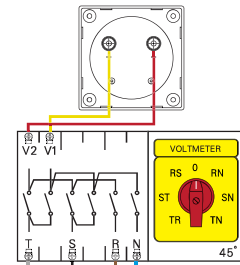

SD-80V

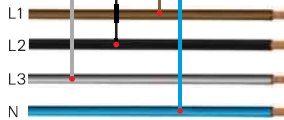

SD-50A

CONNECTION DIAGRAMS

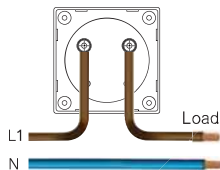

SD-60A

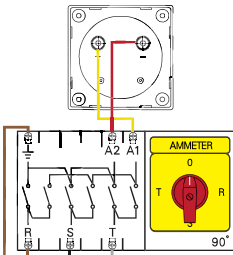

SD-80A

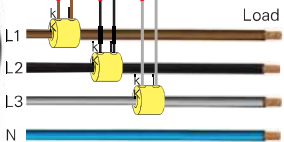

SD-80FP 45...55Hz



SD-80FP 45...65Hz

CONNECTION DIAGRAMS

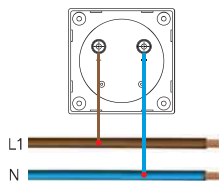

SD-50 Series
SD-60 Series
SD-80 Series
Moving Iron Type

SPECIFICATIONS

- Accuracy Class : 2.5
- Rated Voltage : 600Vac
- Rated Temperature : -25 °C to 40 °C
- Insulation Test : 2KV, 50Hz, 1min

โวลท์มิเตอร์ (VoltMeter) ~ 2.5

รุ่น (Model)	Connection	Measuring Range		ราคา (บาท)
SD-50V	Line/Neutral	0-300V	0-500V	170.-
SD-60V		0-300V	0-500V	190.-
SD-80V		0-300V	0-500V	200.-

แอมป์มิเตอร์ (Ammeter) ~ 2.5

รุ่น (Model)	Connection	Measuring Range					ราคา (บาท)
SD-50A	Direct Connection (ต่อตรง)	5A	10A	15A	20A	170.-	
		30A	40A	50A	60A		
SD-60A	Direct Connection (ต่อตรง)	5A	10A	15A	20A	190.-	
		30A	40A	50A	60A		
SD-80A	Direct Connection (ต่อตรง)	5A	10A	15A	20A	200.-	
		30A	40A	50A	60A		
SD-80A	Through current transformers (5A)	5/5A	10/5A	15/5A	20/5A	200.-	
		30/5A	40/5A	50/5A	60/5A		
		80/5A	100/5A	150/5A	200/5A		
		250/5A	300/5A	400/5A	500/5A		
		600/5A	800/5A	1000/5A			

SD-80 Series Moving Coil Type

มิเตอร์วัดความถี่ (Frequency Meter) ~ 2.5

รุ่น (Model)	Connection Input Voltage	Measuring Range		ราคา (บาท)
SD-80FP	220V	45...55 Hz	45...65 Hz	650.-

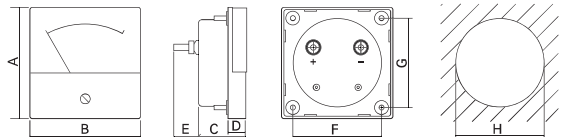

Model	Dimension (mm.)							
	A	B	C	D	E	F	G	H
SD-50	50	50	32.3	10	13	38	38	47
SD-60	60	60	33.3	12	13	48	48	53
SD-80	80	80	35.3	13	13	65	65	66

* ราคาสินค้าไม่รวมภาษีมูลค่าเพิ่มและราคาอาจเปลี่ยนแปลงได้โดยไม่ต้องแจ้งให้ทราบล่วงหน้า *