

**EST3
Installation and Service
Manual**

P/N 270380 • Rev 8.0 • 18SEP08

DEVELOPED BY

GE Security, Inc.
8985 Town Center Parkway
Bradenton, FL 34202
(941) 739-4300

COPYRIGHT NOTICE

© 2008 GE Security, Inc.

This manual is copyrighted by GE Security, Inc. (GE Security). You may not reproduce, translate, transcribe, or transmit any part of this manual without express, written permission from GE Security.

This manual contains proprietary information intended for distribution to authorized persons or companies for the sole purpose of conducting business with GE Security. Unauthorized distribution of the information contained in this manual may violate the terms of the distribution agreement.

TRADEMARKS

Microsoft, Microsoft Mouse, Microsoft Windows, Microsoft Word, and Microsoft Access are either registered trademarks or trademarks of Microsoft Corporation.

	Important information • v
	UL 864 9th edition requirements • vii
	About this manual • x
	The EST3 library • xii
	Related documentation • xiii
Chapter 1	System overview • 1.1
	System description • 1.2
	Audio subsystem description • 1.6
	Digital network subsystem • 1.16
	Foreign language support • 1.22
	Signature series devices • 1.26
	Network applications • 1.29
	Audio applications • 1.33
	Firefighter phone system • 1.42
Chapter 2	Security applications • 2.1
	Security equipment • 2.2
	Certificate installations • 2.8
	Multiple 3-MODCOM modules • 2.13
	Multiple site security and access • 2.14
	Multiple tenant security • 2.17
	Secure access • 2.21
Chapter 3	Access control applications • 3.1
	Access control equipment • 3.2
	Anti-passback • 3.11
	Central monitoring station • 3.14
	Common door access • 3.16
	Delayed egress • 3.18
	Elevator control • 3.21
	Emergency exit door • 3.24
	Handicap access door • 3.26
	Maglock peripherals • 3.28
	Multiple card readers • 3.30
	Muster • 3.32
	Power for continuous locks • 3.35
	Power for intermittent locks • 3.37
	Power from an AC source • 3.39
	Power from a remote source • 3.42
	Remote controls • 3.45
	Two-person rule • 3.47
Chapter 4	Centralized audio applications • 4.1
	Equipment required • 4.2
	ATPC Amplifier Terminal Panel Cabinet • 4.3
	ATP Amplifier Terminal Panel • 4.6
	Audio amplifiers • 4.8
	URSM Universal Riser Supervisory Module • 4.10

ATP external battery charger • 4.20
Amplifier backup • 4.22
Branch speaker wiring • 4.25
Troubleshooting • 4.27

Chapter 5

Installation • 5.1

Installation overview • 5.3
UL 864 NAC signal synchronization • 5.6
Creating an initial startup version of the project database • 5.16
System installation sequence • 5.18
Preliminary field wiring testing • 5.19
Chassis installation in EIA 19-inch racks • 5.22
ATCK Attack Kit for cabinets • 5.23
Local rail module installation • 5.24
3-MODCOM Modem Communicator module • 5.26
3-SAC Security Access Control module • 5.40
3-AADC1 Addressable Analog Driver Controller and IRC-3 • 5.41
AC power and DC battery wiring • 5.42
Connecting auxiliary/booster power supplies • 5.44
Connecting the PT-1S impact printer • 5.46
Adjusting amplifier output levels • 5.49
Connecting a CDR-3 Zone Coder for coded tone output • 5.50
Connecting an external modem for use with the Remote
Diagnostics Utility • 5.53
Running the RPM and distributing profiles • 5.55

Chapter 6

Power-up and testing • 6.1

Cabinet power-up procedure • 6.3
Runtime and system errors • 6.4
Initial and reacceptance test procedures • 6.6
Control and emergency communications equipment testing • 6.7
Detector, input module, and output module testing • 6.18
Initiating device testing • 6.21
Notification appliance testing • 6.23
Record of completion • 6.24

Chapter 7

Preventive maintenance • 7.1

General • 7.2
Preventive maintenance schedule • 7.3
Signature device routine maintenance tips • 7.5
Signature detector cleaning procedure • 7.6
System trouble and maintenance log • 7.7

Chapter 8

Service and troubleshooting • 8.1

Overview • 8.3
Hardware problems • 8.5
Modules • 8.7
Audio components • 8.20
Pseudo point descriptions • 8.24
Signature data circuit (SDC) operation • 8.35
Basic Signature data circuit troubleshooting • 8.37
Signature controller modules • 8.47
Device troubleshooting • 8.49
Signature diagnostic tools • 8.51

DSDC status • 8.65
Addressable analog diagnostic tools • 8.70
3-AADC1 Addressable Analog Driver Controller • 8.74
Addressable analog device troubleshooting • 8.75
Wiring problems • 8.77

Appendix A

System addresses • A.1

Address format • A.2
LRM addresses • A.4
Control / display module addresses • A.9
Device addresses • A.10

Appendix B

System calculations • B.1

Network data riser limits • B.2
Signature data circuit wire length • B.5
Notification appliance circuit calculations • B.11
25 or 70 Vrms NAC wire length • B.17
Addressable analog circuit wire length • B.19
Cabinet battery • B.20
SAC bus power • B.21
CPU memory • B.26
Fiber optic cable worksheet • B.28

Appendix C

Listing requirements • C.1

NFPA standards • C.2
Minimum requirements for UL security applications • C.3
UL and ULC requirements • C.10

Y

Glossary • Y.1

Z

Index • Z.1

Important information

Limitation of liability

This product has been designed to meet the requirements of NFPA Standard 72; Underwriters Laboratories, Inc., Standard 864; and Underwriters Laboratories of Canada, Inc., Standard ULC S527. Installation in accordance with this manual, applicable codes, and the instructions of the Authority Having Jurisdiction is mandatory. GE Security shall not under any circumstances be liable for any incidental or consequential damages arising from loss of property or other damages or losses owing to the failure of GE Security products beyond the cost of repair or replacement of any defective products. GE Security reserves the right to make product improvements and change product specifications at any time.

While every precaution has been taken during the preparation of this manual to ensure the accuracy of its contents, GE Security assumes no responsibility for errors or omissions.

FCC warning

This equipment can generate and radiate radio frequency energy. If this equipment is not installed in accordance with this manual, it may cause interference to radio communications. This equipment has been tested and found to comply within the limits for Class A computing devices pursuant to Subpart B of Part 15 of the FCC Rules. These rules are designed to provide reasonable protection against such interference when this equipment is operated in a commercial environment. Operation of this equipment is likely to cause interference, in which case the user at his own expense, will be required to take whatever measures may be required to correct the interference.

Industry Canada information

Note: The Industry Canada label identifies certified equipment. This certification means that the equipment meets certain telecommunications network protective, operational, and safety requirements. Industry Canada does not guarantee the equipment will operate to the user's satisfaction.

Before installing this equipment, users should ensure that it is permissible to be connected to the facilities of the local telecommunications company. The equipment must also be installed using an acceptable method of connection. The customer should be aware that compliance with the above conditions may not prevent degradation of service in some situations.

Repairs to certified equipment should be made by an authorized Canadian maintenance facility designated by the supplier. Any repairs or alterations made by the user to this equipment, or equipment malfunctions, may give the telecommunications company cause to request the user disconnect the equipment.

Users should ensure for their own protection that the electrical ground connections of the power utility, telephone lines, and internal metallic water pipe system, if present, are connected together. This precaution may be particularly important in rural areas.

Caution: Users should not attempt to make such connections themselves, but should contact the appropriate electric inspection authority, or electrician, as appropriate

Note: The Load Number (LN) assigned to each terminal device denotes the percentage of the total load to be connected to a telephone loop that is used by the device, to prevent overloading. The termination on a loop may consist of any combination of devices subject only to the requirements that the sum of the Load Numbers of all the devices does not exceed 100.

UL 864 9th edition requirements

NOTICE TO USERS, INSTALLERS, AUTHORITIES HAVING JURISDICTION, AND OTHER INVOLVED PARTIES

This product incorporates field-programmable software. In order for the product to comply with the requirements in the Standard for Control Units and Accessories for Fire Alarm Systems, UL 864, certain programming features or options must be limited to specific values or not used at all as indicated below.

Programmable feature or option	Permitted in UL 864? (Y/N)	Possible settings	Settings permitted in UL 864
Enable Supervision (telephone line is supervised for ground faults, a single open line, or a wire-to-wire fault)	Y	No Yes	Yes
DACT Settings - Line 2 Installed (single line or dual line dialer)	Y	No Yes	Yes
Trouble Resound (panel resound)	Y	Disabled (0) 1 second to ~99 hours	Disabled [2] 0 to 24 hours
AC Power Delay	Y	Disabled 1 minute to 45 hours	1 to 3 hours
Event message routing	Y	All Cabinets No Cabinets User defined routes (1 to 15)	All Cabinets No Cabinets [3] User defined routes (1 to 15) [4]
Event message display filtering: Alarm, Supervisory, and Trouble options	Y	Enabled Disabled	Enabled Disabled [5]
Delays (programmed in rules)	Y	0 to 240 seconds	0 to 240 seconds [6]
CMS event reporting priority (programmed in rules)	Y	1 to 255	1 to 255 [7]
CMS activate and restore messages (programmed in rules)	Y	Send on activation Send on restoration	Activation and restoration triggers must match the message type
4-state alarm IDC	N	N/A	In Signature module configuration, personality code 18 is prohibited [11]

Programmable feature or option	Permitted in UL 864? (Y/N)	Possible settings	Settings permitted in UL 864
Alarm zone group members	Y	Alarm device type Pull device type Heat device type Verified smoke device type Water flow device type	Alarm device type [8] Pull device type Heat device type Verified smoke device type Water flow device type
AND group members	Y	Alarm device type Pull device type Heat device type Verified smoke device type Water flow device type Alarm zone device type Fire zone device type Matrix group device type	Alarm device type [8] Pull device type Heat device type Verified smoke device type [9] Water flow device type Alarm zone device type Fire zone device type Matrix group device type
AND group device activation count	Y	1 to 255	1 to 255 [10]
Matrix groups: Members	Y	Alarm device type Pull device type Fire device type Call point device type Heat device type Verified smoke device type Water flow device type	Alarm device type [8] Pull device type Fire device type [8] Call point device type Heat device type Verified smoke device type [9] Water flow device type
Matrix groups: Device activation count	Y	3 to 10	3 to 10 [10]

Programmable feature or option	Permitted in UL 864? (Y/N)	Possible settings	Settings permitted in UL 864
--------------------------------	----------------------------	-------------------	------------------------------

Notes

- [1] Allowed only when the supervising station supervises the telephone line and annunciates fault conditions within 200 seconds
- [2] Allowed only on control panels that transmit trouble event signals off premises
- [3] Allowed only with monitor device types and switches
- [4] Allowed only if user route includes the control panel
- [5] Allowed only on nonrequired remote annunciators
- [6] Allowed only when setting does not prevent the activation or transmission of alarm or supervisory signals within 10 seconds or trouble signals within 200 seconds
- [7] When priorities are used, alarm events must have a higher priority than supervisory and trouble events.
- [8] Allowed in alarm zone groups, AND groups, and matrix groups that are used to initiate the release of extinguishing agents or water except when the addressable smoke detector's alarm verification is used.
- [9] Allowed only in alarm zone groups, AND groups, and matrix groups that are not used to initiate the release of extinguishing agents or water
- [10] A minimum device activation count of 2 is required if the AND group or matrix group is used to initiate the release of extinguishing agents or water
- [11] Personality code 18 is typically used when a short condition must be distinguished from an alarm condition. This type of IDC is prohibited by UL 864.

About this manual

This manual provides information on how to properly install, wire, and maintain the EST3 integrated system and related components. This manual applies to the following EST3 models:

- EST3
- EST3R
- EST3-230
- EST3R-230

Organization

Chapter 1: System overview: a descriptive overview of the components and subsystems that comprise an EST3 system.

Chapter 2: Security applications: covers security applications. This chapter contains block diagrams that show the components required to create specific security systems.

Chapter 3: Access control applications: covers access control applications. Like Chapter 2, this chapter contains block diagrams and descriptions of specific access control systems.

Chapter 4: Centralized audio applications: describes the equipment and configuration required to create centralized audio for a site.

Chapter 5: Installation: installation information for system components and applications that supplement the instructions provided on individual component installation sheets.

Chapter 6: Power-up and testing: information and procedures necessary to perform initial system power-up and acceptance testing.

Chapter 7: Preventive maintenance: lists the required scheduled maintenance items and procedures.

Chapter 8: Service and troubleshooting: a comprehensive set of procedures and tables to aid certified technical personnel in servicing and troubleshooting the system.

Appendices A, B, and C provide supplementary information about system addressing, calculations, and compatibility.

Safety information

Important safety admonishments are used throughout this manual to warn of possible hazards to persons or equipment.

Caution: Cautions are used to indicate the presence of a hazard which will or may cause damage to the equipment if safety instructions are not followed or if the hazard is not avoided.

WARNING: Warnings are used to indicate the presence of a hazard which will or may cause personal injury or death, or loss of service if safety instructions are not followed or if the hazard is not avoided.

The EST3 library

EST3 documents

A library of documents and multi-media presentations supports the EST3 life safety system. A brief description of each is provided below.

EST3 Installation and Service Manual (P/N 270380): Gives complete information on how to install and service the EST3 hardware. The manual also includes installation information on selected Signature Series components.

SDU Online Help (P/N 180653): Provides full online support for configuring and programming a system using the System Definition Utility program.

EST3 System Operation Manual (P/N 270382): Provides detailed information on how to operate the system and system components.

EST3 Smoke Management Application Manual (P/N 270913): Provides information for designing, programming, and testing an EST3 smoke control system.

EST3 ULI ULC Compatibility Lists (P/N 3100427): Lists the appliances, devices, and accessories that are compatible with EST3.

Other documents

In addition to documents in the EST3 library, you may find the following documents useful.

Signature Series Intelligent Smoke and Heat Detectors Applications Bulletin (P/N 270145): Provides additional applications information on the Signature series smoke and heat detector applications.

Signature Series Component Installation Manual (P/N 270497): Contains detailed mounting and wiring information for all Signature series devices.

Speaker Application Guide (P/N 85000-0033): Provides information on the placement and layout of speakers for fire alarm signaling and emergency voice communications.

Strobe Applications Guide (P/N 85000-0049): Provides information on the placement and layout of strobes for fire alarm signaling.

Related documentation

National Fire Protection Association

1 Batterymarch Park
P.O. Box 9101
Quincy, MA 02269-9101

NFPA 70 National Electric Code
NFPA 72 National Fire Alarm Code
NFPA 11 Low-Expansion Foam Systems
NFPA 11A Medium- and High-Expansion Foam Systems
NFPA 12 Carbon Dioxide Extinguishing Systems
NFPA 13 Sprinkler Systems
NFPA 15 Water Spray Fixed Systems for Fire Protection
NFPA 16 Deluge Foam-Water Sprinkler and Foam-Water Spray Systems
NFPA 17Dry Chemical Extinguishing Systems

Underwriters Laboratories, Inc.

333 Pfingsten Road
Northbrook, IL 60062-2096

UL 38 Manually Actuated Signaling Boxes
UL 217 Smoke Detectors, Single & Multiple Station
UL 228 Door Closers/holders for Fire Protective Signaling Systems
UL 268 Smoke Detectors for Fire Protective Signaling Systems
UL 268A Smoke Detectors for Duct Applications
UL 346 Waterflow Indicators for Fire Protective Signaling Systems
UL 464 Audible Signaling Appliances
UL 521 Heat Detectors for Fire Protective Signaling Systems
UL 864 Standard for Control Units for Fire Protective Signaling Systems
UL 1481 Power Supplies for Fire Protective Signaling Systems
UL 1638 Visual Signaling Appliances
UL 1971 Visual Signaling Appliances

**Underwriters Laboratories of
Canada**

7 Crouse Road
Scarborough, ON
Canada M1R 3A9

Canadian Electrical Code Part 1

ULC S527 Standard for Control Units for Fire Alarm
Systems

ULC S524 Standard for the Installation of Fire Alarm
Systems

ULC S536 Standard for the Inspection and Testing of
Fire Alarm Systems

ULC S537 Standard for the Verification of Fire Alarm
Systems

ULC ORD–C693–1994 Central Station Fire Protective
Signaling System and Services

CAN/ULC-S301 Standard for Central and Monitoring
Station Burglar Alarm Systems

CAN/ULC-S302 Standard for Installation and
Classification of Burglar Alarm Systems for Financial
and Commercial Premises, Safes, and Vaults

CAN/ULC-S303 Standard for Local Burglar Alarm Units
and Systems

CAN/ULC-S304 Standard for Central and Monitoring
Station Burglar Alarm Units

PLUS: Requirements of state and local building codes and the
local authority having jurisdiction.

Summary

This chapter provides a descriptive overview of the components and subsystems that comprise a system.

Content

- System description • 1.2
 - System features • 1.3
 - Minimum system requirements • 1.4
 - System construction • 1.4
- Audio subsystem description • 1.6
 - Network audio riser wiring • 1.6
 - Amplifiers • 1.7
 - Backup amplifiers • 1.8
 - 3-ASU Audio Source Unit • 1.9
 - Firefighter phone • 1.15
- Digital network subsystem • 1.16
 - Network data riser wiring • 1.16
 - Class B network data risers • 1.16
 - Class A network data risers • 1.17
 - Download connections • 1.18
 - Downloading database files over the network • 1.19
- Foreign language support • 1.22
 - Printer use with foreign languages • 1.22
 - Bilingual language support • 1.22
 - Display device language support • 1.23
- Signature series devices • 1.26
- Network applications • 1.29
 - Network layout • 1.29
 - Feature/function domain • 1.30
- Audio applications • 1.33
 - Audio channels • 1.34
 - Manual audio zone selection • 1.38
 - Messages • 1.39
- Firefighter phone system • 1.42
 - Five phone off-hook limit • 1.42
 - One phone per circuit • 1.42
 - Five phones per circuit • 1.43
 - Limited number of portable telephone handsets • 1.43

System description

EST3 is designed using modular hardware and software components to facilitate rapid configuration, installation, and testing. Most network components are provided as local rail modules (LRMs) that plug into the rail chassis assemblies. Rail chassis assemblies are available to meet most any application.

Rail modules are used for data processing, intrapanel communication of command/control data, response data, audio signal processing, and power distribution. Each rail module provides an interface to support a control/display module that can be mounted on the front of the module. Most field wiring is terminated using removable terminal strips for easy installation and servicing of modules.

Cabinets are available in a variety of sizes. The smallest (3-CAB5), in addition to the central processor module and primary power supply module, supports two rail modules and three control/display modules. The largest, the 3-CAB21 supports as many as 18 rail modules and 19 control/display modules.

An EST3 cabinet can be configured as a stand-alone system or as part of a network which supports up to 64 cabinets on a peer-to-peer Class A or B token ring network. Below is a partial list of local rail modules that can be incorporated into a system:

- Central Processor module (CPU). One is required for each panel. Several models of CPU are available. See the current compatibility lists for details.
- Primary Power Supply module (3 PPS/M, 3 BPS/M, or 3 BBC/M). One power supply module is required for each panel.
- Main LCD Display module (LCD). One LCD is required to provide a point of control for the entire network. Additional displays can be added to any CPU module for additional points of control or annunciation. Several LCD models are available. See the current compatibility lists for details.

Additional control/display modules as required by the application:

- 3-BPS/M Booster Power Supply module
- 3-MODCOM Modem Communicator module
- 3-SAC Security Access Control module
- 3-SSDC(1) Signature Driver Controller module
- 3-AADC(1) Analog Addressable Driver Controller module
- 3-IDC8/4 Initiating Device Circuit module
- 3-OPS Off-Premises Signaling module
- 3-ZAxx Zoned Amplifier modules

The audio and firefighter phone functions use a different hardware format, providing operator controls and storage for the microphone and telephone handset in a chassis configuration.

System features

Each cabinet in the system provides local control, display, power supply, and communication functions. Each cabinet has the following capacities:

- 10 addressable device circuits (Signature and addressable analog combined)
- 120 traditional input / output zones
- 4 Class B (2 Class A) security / access control communication (SAC) busses
- 10 modem / dialer cards, each with two telephone lines
- 2 RS-232 external peripheral device ports
- 456 LED annunciation points
- 342 input switches

In addition, the EST3 system has these global features:

- Firefighter telephone
- Custom programmability and user-friendly front panel
- Class B (Style B), initiating device circuits (IDC)
- Event reporting by alarm, trouble, supervisory, or monitor mode and message display routing
- Dead front construction
- Supports networking — up to 64 nodes may be connected in a regenerative Class A or Class B token ring
- Fast response time, less than three seconds from initial alarm to device activation on a fully loaded system over the network
- Flash memory on controller modules to facilitate quick firmware upgrades
- Supports 255 security partitions
- Multiplexed eight-channel digital audio system
- Transient protected field wiring
- Class B (Style Y) or Class A notification appliance circuits
- Ground fault detection by panel, Signature data circuit, and Signature modules
- Switch mode power supply

- Copper or fiber network and audio communications
- Application and firmware downloading over the network or from a single point
- Network-wide control routing
- Form C alarm, supervisory, and trouble relay contacts

Refer to the release notes for the latest information regarding specifications and capabilities.

Minimum system requirements

NFPA 72 system classification	Required control equipment
Protected Premises (Local)	Cabinet with a CPU (Central Processor module), one LCD (Main LCD Display module) one 3-PPS/M Primary Power Supply and Monitor, appropriate batteries, plus appropriate initiating device circuits and notification appliance circuits
Auxiliary —or— Remote Station —or— Proprietary Protected Premises	Add a 3-OPS Off Premises Signal module or a correctly configured and programmed 3-MODCOM Modem Communicator module to the protected premises system

System construction

The EST3 system is assembled in layers as shown in Figure 1-1. The cabinet (1) houses all the system components. A variety of cabinets are available for as few as 5 and as many as 21 modules. A 3-RCC14 cabinet is illustrated in Figure 1-1.

Mounted directly to the cabinets are the rail chassis assemblies (2), of which there are three types: rail, audio, and audio with telephone. The most common chassis is the rail chassis, which provides mounting and electrical connections for the local rail modules (LRMs) (4). Mounted on the rear of the chassis are the cabinet power supplies (3).

The local rail modules (4) are the specialized cards that provide an interface between the CPU and the field wiring. The front of any rail module can support a control/display module (5), providing customized operator controls and annunciators.

Completing the EST3 “CAB” series cabinet assembly are the inner (6) and outer (7) doors. The “RCC” cabinets use a single outer door.

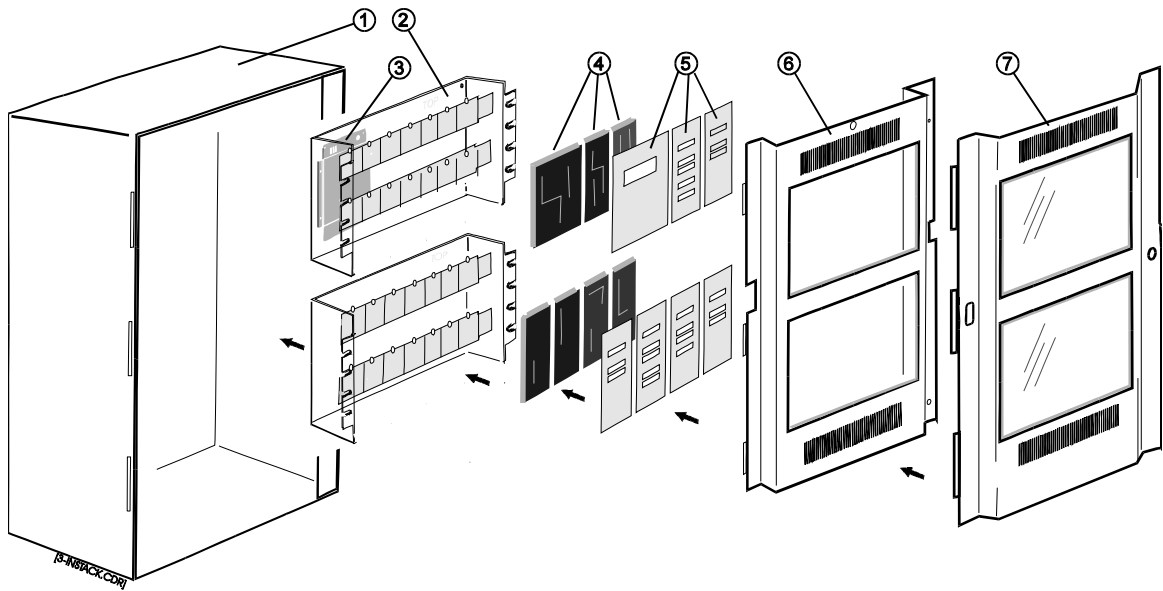

Figure 1-1: Exploded CAB series cabinet equipment installation

Audio subsystem description

The audio subsystem consists of a variety of signal sources, integral amplifiers, and sophisticated control software. The 3-ASU Audio Source Unit is available with the optional 3-FTCU Firefighter Telephone Control Unit as the model 3-ASU/FT. The ASU/FT is the only audio equipment required at the fire command control center. Zoned audio amplifiers are distributed throughout the system and provide the de-multiplexing, switching, amplification and circuit supervision.

Network audio riser wiring

A digital network audio riser consisting of a single pair (Class B) or two pairs (Class A) of wires connect all amplifiers together. Since the digital signals are multiplexed, any of 8 independent audio sources can be directed to any amplifier connected to the network. All command and control signals for the audio system are distributed over the network data riser.

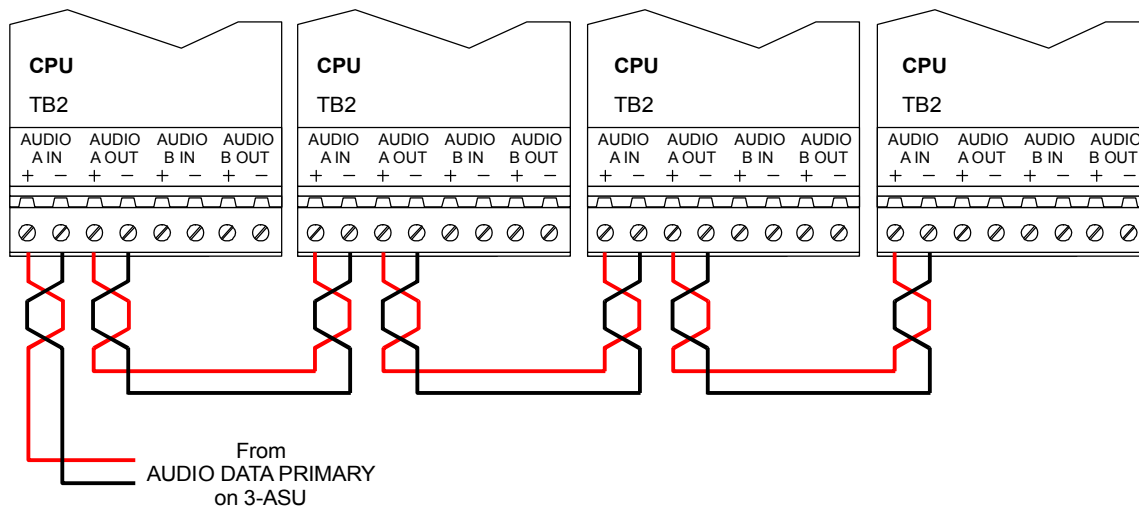

Figure 1-2: Class B network audio riser wiring

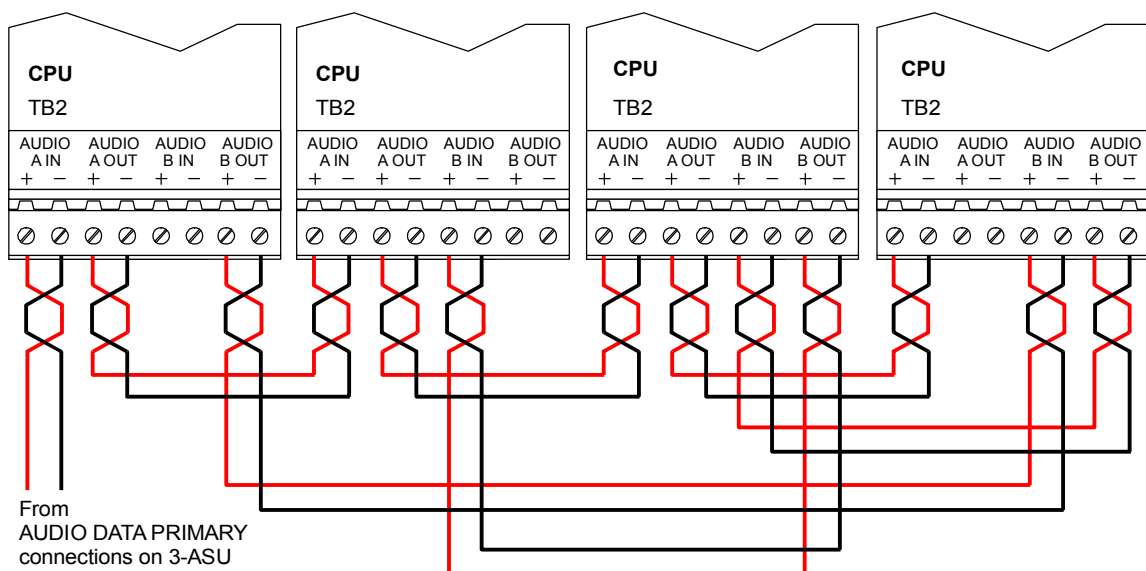

Figure 1-3: Class A network audio riser wiring

Amplifiers

Amplifiers are designed to feed a single audio zone and provide an integral 24 Vdc visual notification appliance circuit. Amplifier modules are available in 20-, 40-, and 95-watt versions, with each amplifier providing a single supervised Class B or A audio output circuit. The amplifier is configurable for either 25 Vrms or 70 Vrms output. An independent supervised Class B or Class A, 24 Vdc, 3.5 Amp notification appliance circuit (NAC) is also provided on the 20- and 40-watt amplifiers to drive notification appliances. In addition, automatic backup amplifiers can be added on a switched common backup configuration.

Each audio power amplifier has an integral demultiplexer, making the 8 audio channels available to the amplifier's input, as directed by the system programming. Each amplifier also contains circuitry that handles routine signal processing functions such as channel priority.

The amplifier's output is a dedicated, supervised, 25-, 70-Vrms speaker circuit, which covers one audio zone in the protected facility. Figure 1-4 is an example of an enclosure with four zone amplifiers and a backup amplifier. In response to an alarm, selected audio amplifiers have been connected to the required audio channels. Note that three different audio signals are being broadcast simultaneously.

System overview

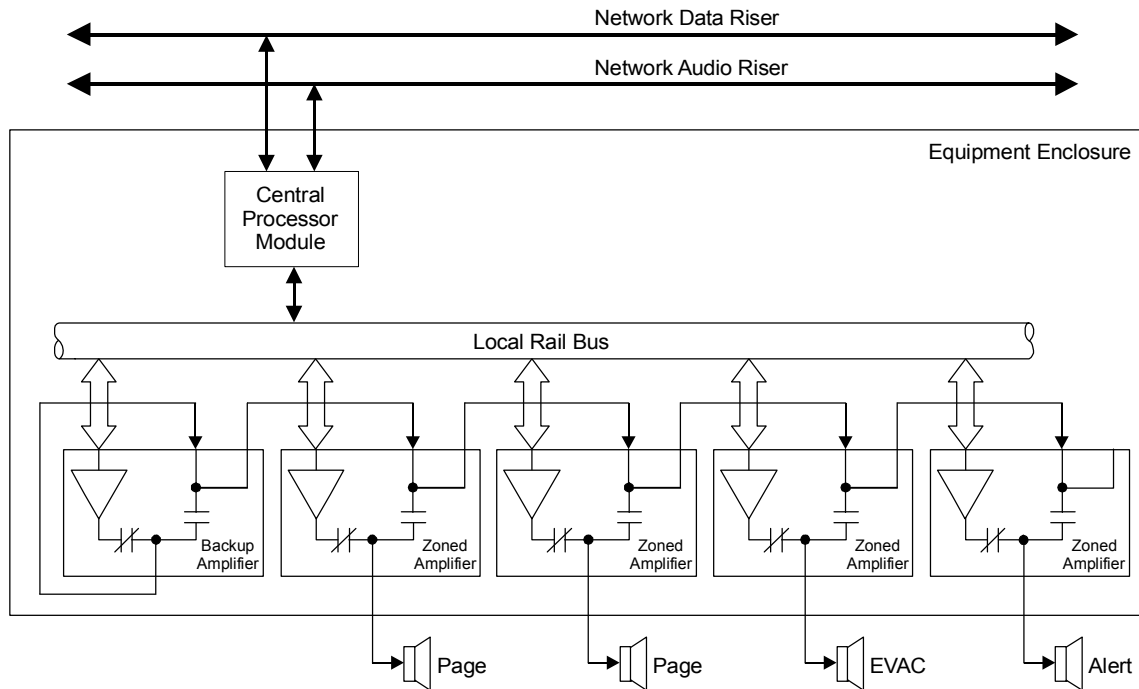

Figure 1-4: Normal amplifier operation

Possible fault condition	Amplifier operation
Amplifier loses communication with Central Processor module	<p>If the panel is configured for stand-alone operation, the amplifier automatically switches to the EVAC channel and outputs its 1 kHz temporal tone when the panel detects an alarm.</p> <p>If the panel is not configured for stand-alone operation, the amplifier will not output any signal.</p>
Panel loses communication with network data riser	Amplifier switches to the EVAC channel only in response to the local panel's programming uses the default EVAC message.
Panel loses communication with network audio riser	Amplifier switches to the EVAC channel in response to the system programming. For EVAC the amplifier uses its 1 kHz temporal tone. For Alert the amplifier uses its 1 kHz 20 bps tone.

Backup amplifiers

In the event of an amplifier failure (not a field wiring problem), the backup amplifier automatically replaces the failed amplifier, as shown in Figure 1-5.

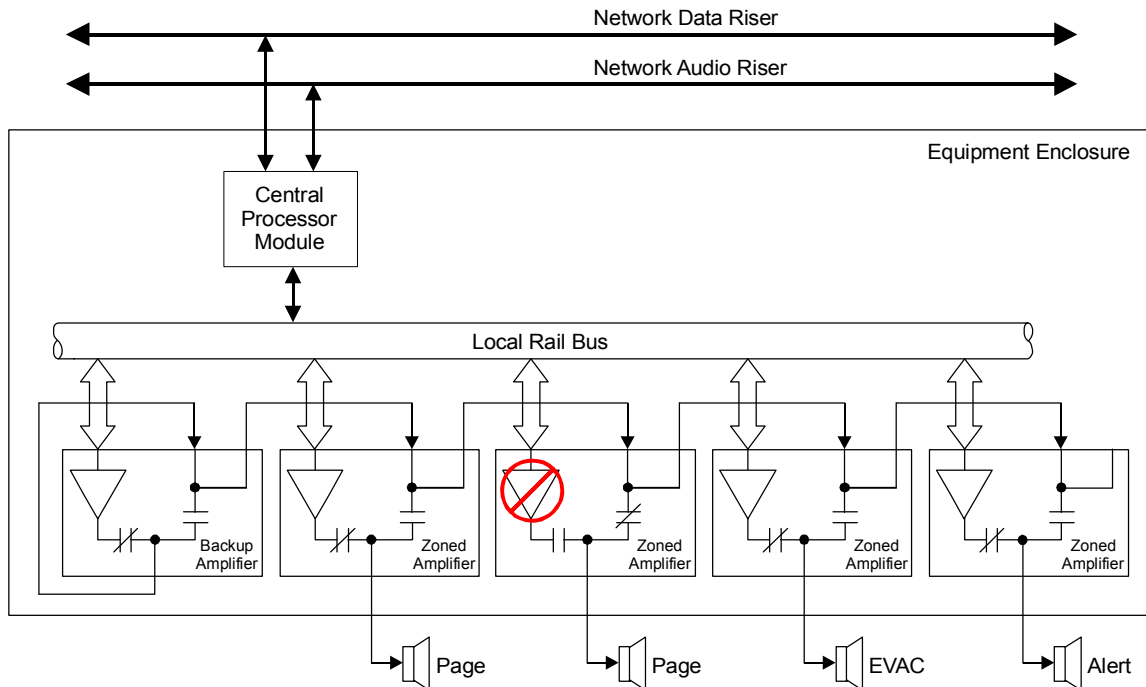

Figure 1-5: Single amplifier failure

Note: The backup amplifier will back up a failed amplifier if it was being used for Page, EVAC, or Alert. It will not back up an amplifier being used on an Auxiliary or General channel.

The amplifier failure caused the backup amplifier to automatically connect to the same audio source as the failed amplifier. The output of the backup amplifier replaced the output of the failed amplifier.

Note: The backup amplifier will not replace an amplifier that has detected a field wiring problem to prevent the amplifier from driving into a shorted circuit.

3-ASU Audio Source Unit

The 3-ASU is the source of the network audio riser. Available audio sources are local and remote voice PAGE functions and the firefighter telephone PAGE function. An integral tone generator database is provided for the EVAC, ALERT and other functions. Alternately, the 3-ASU's integral digital voice message playback unit can simultaneously provide up to 8 different prerecorded audio messages that may be assigned to any channel.

The multiplexer within the 3-ASU converts and compresses the real-time audio signal and converts it to a digital format. The output of the digital message playback unit and the integral tone generator database is already in the digital format. The 8 signal sources in digital format are then combined together as selected by the system designer using a multiplexer. This makes up the network audio riser signal.

System overview

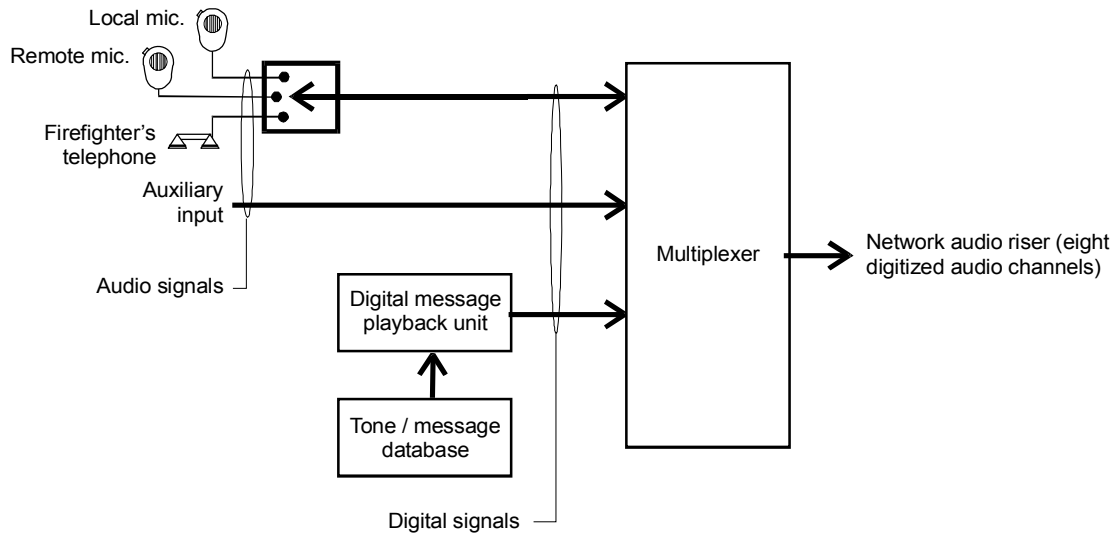

Figure 1-6: ASU Signal Flow

The amplifiers at the remote-panels extract the audio signals from the network riser, amplify it and send it to the speakers.

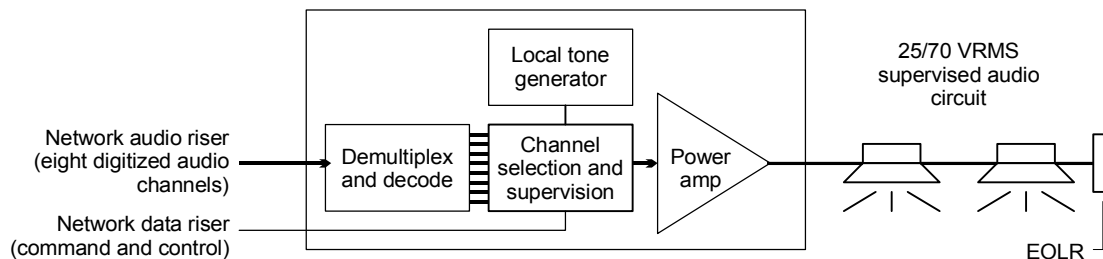

Figure 1-7: Amplifier Signal Flow

Audio signal priority

During system configuration, each of the eight available audio channels is assigned one of the five available attributes listed in Table 1-1. The Page, and Auxiliary attributes may only be assigned to a single channel. The General attribute may be assigned to up to four channels.

Table 1-1: Network audio channel parameters

Channel attribute	Priority
PAGE	1
EVAC	2
ALERT	3
AUXILIARY	4

Table 1-1: Network audio channel parameters

Channel attribute	Priority
GENERAL	5

Each channel attribute has a priority level associated with it. When more than one channel is commanded to source a given amplifier, the amplifier will connect to the source having the highest priority. The Page channel will only go active when the microphone push-to-talk switch is pressed.

Special audio source unit page modes

The front panel of the ASU offers four special page mode switches:

- All Call
- EVAC
- Alert
- All Call Minus

These switches provide instantaneous switching of the page signal to the most frequently contacted areas of the building. The special page modes do *not* require any source switching by the zoned audio amplifiers. When a special page mode switch is activated, the signal content of the eight outgoing audio channels is modified. Figure 1-8 illustrates this principle.

In the *normal page mode*, the eight audio signal sources are each connected to a separate audio channel, as represented by a ■ at the intersection of the signal source and the audio channel, shown at the lower left of Figure 1-8. Each audio channel is represented as a vertical line in this figure. The eight audio channels are actually multiplexed together and distributed over a common pair of wires called the network audio riser. The figure shows the system in the normal page mode, with the zoned audio amplifiers processing EVAC signals on the 1st and 3rd levels, a page signal on the 2nd level, and the alert signal on the 4th level.

System overview

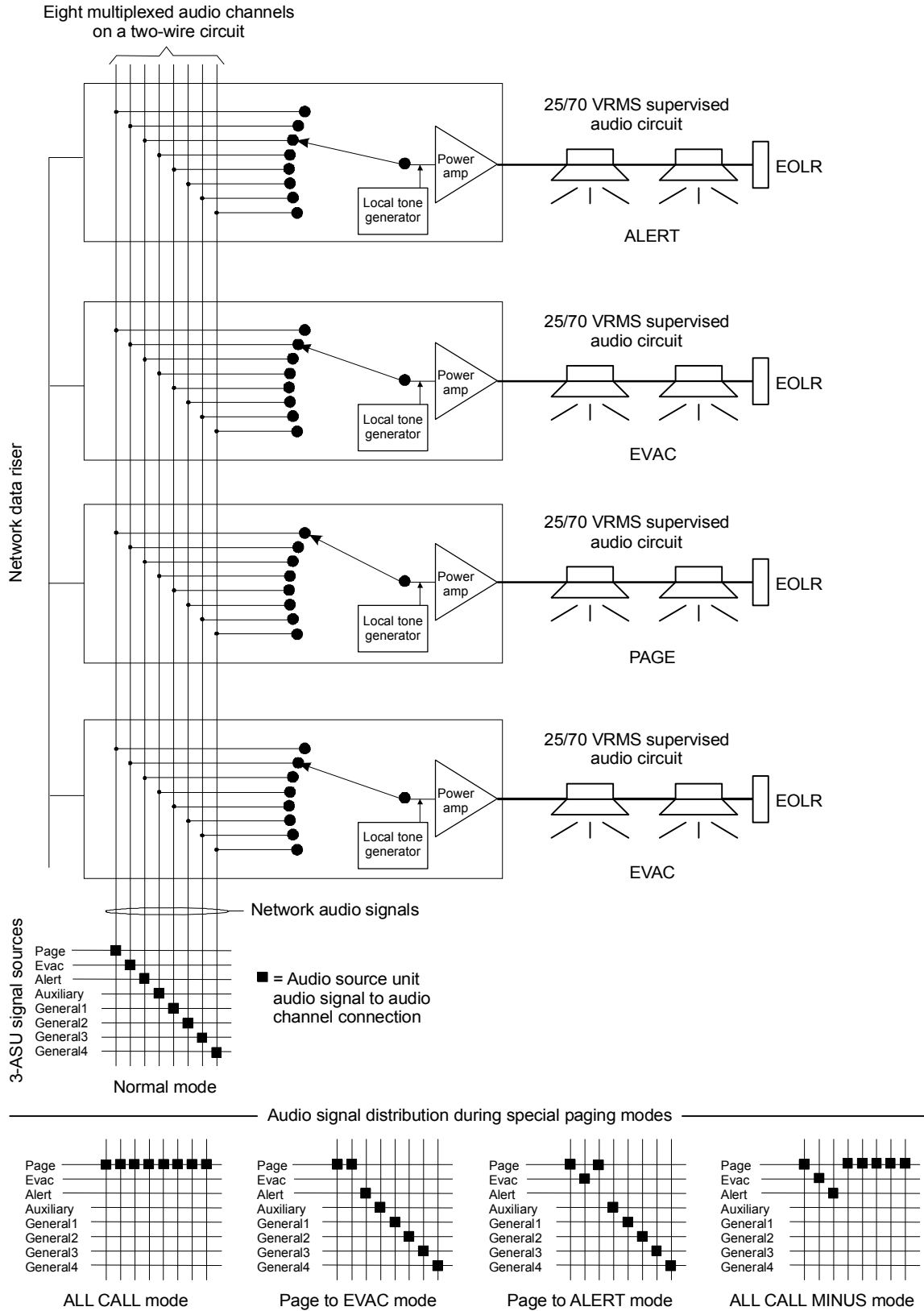

Figure 1-8: Audio Source Unit Special Page Mode Signal Flow

The *All Call* mode is used to send a page to the entire facility. When the All Call switch is activated, the Audio Source Unit is put into the all call mode. In this mode, the zoned audio amplifiers do not all transfer to the page channel. Rather, the Audio Source Unit redirects the page signal source to all the audio channels. Figure 1-8 shows the all call page source to audio channel connections in the lower left corner. Note that all channels receive the same signal. Any amplifier on the system, regardless of the audio channel selected, will receive the page. Any amplifiers that were previously idle will power up and receive the page.

The *Page to EVAC* mode is used to send a page to the areas automatically receiving the evacuation signal. Activating the EVAC switch causes the Audio Source Unit to enter the page to EVAC mode. In this mode, the zoned audio amplifiers connected to the EVAC channel do not transfer to the page channel. Rather, the Audio Source Unit redirects the page signal source to the EVAC channel. Figure 1-8 shows the page to EVAC mode page source to EVAC channel connections. The page and EVAC audio channels both receive the page signal. Any amplifier connected to either the page or EVAC audio channels will receive the page. The alert, auxiliary and general channels are connected to their respective signal sources, as in the normal mode.

The *Page to Alert* mode is used to send a page to the areas automatically receiving the alert signal. Activating the Alert switch causes the Audio Source Unit to enter the page to alert mode. In this mode, the zoned audio amplifiers connected to the alert channel do not transfer to the page channel. Rather, the Audio Source Unit redirects the page signal source to the alert channel. Figure 1-8 shows the page to alert mode page source to alert channel connections. The page and alert audio channels both receive the page signal. Any amplifier connected to either the page or alert audio channels will receive the page. Any amplifiers that were previously idle will power up and receive the page. The EVAC, auxiliary and general channels are connected to their respective signal sources, as in the normal mode.

The *All Call Minus* mode is used to send a page to all areas NOT automatically receiving the EVAC or alert signals. In high rise applications, all call minus is an effective way to quickly select stairwells. Activating the All Call Minus switch causes the Audio Source Unit to enter the all call minus mode. In this mode, the zoned audio amplifiers connected to the auxiliary and general channels do not transfer to the page channel. Rather, the Audio Source Unit redirects the page signal source to the auxiliary and four general channels. Figure 1-8 shows the all call minus mode page source to auxiliary and general channel connections. The

page, auxiliary and four general audio channels all receive the page signal. Any amplifier connected to the page, auxiliary or general audio channels will receive the page. The EVAC and alert channels are connected to their respective signal sources, as in the normal mode.

Automatic messaging

One of the features of the 3-ASU Audio Source Unit is the method used to monitor the integrity of the digital audio system. When an audio messaging system is configured, default audio messages are recorded for the Evacuation and Alert channels. The text of default messages should be generic in nature, and should not include location-specific instructions. When the system is in the normal condition, the 3-ASU continuously transmits default messages over the network audio riser. The zone amplifiers use the default messages to verify their operational integrity, as well as the integrity of the riser wiring.

When an alarm is detected, the evacuation and alert message channels are selected by the amplifiers in the appropriate areas in the facility, as directed by the system rules. If a specific evacuation message has been programmed to play in response to the alarm, it is sent out over the evacuation channel. Location specific evacuation messages contain information and instructions that should only be used for a specific alarm location. Should a second alarm from another location be received, the evacuation message playing as a result of the first alarm may not be appropriate for the second alarm.

Note: In the event of conflicting messaging instructions caused by multiple alarm events, the system will play the default evacuation message, whenever two or more different messages are requested at the same time on the evacuation channel.

Automatic message processing is illustrated in Figure 1-9. By reverting back to the generic default evacuation message in multiple alarm location scenarios, no one can be misdirected by the wrong message. Default messages also play during alarms when no location specific message has been requested.

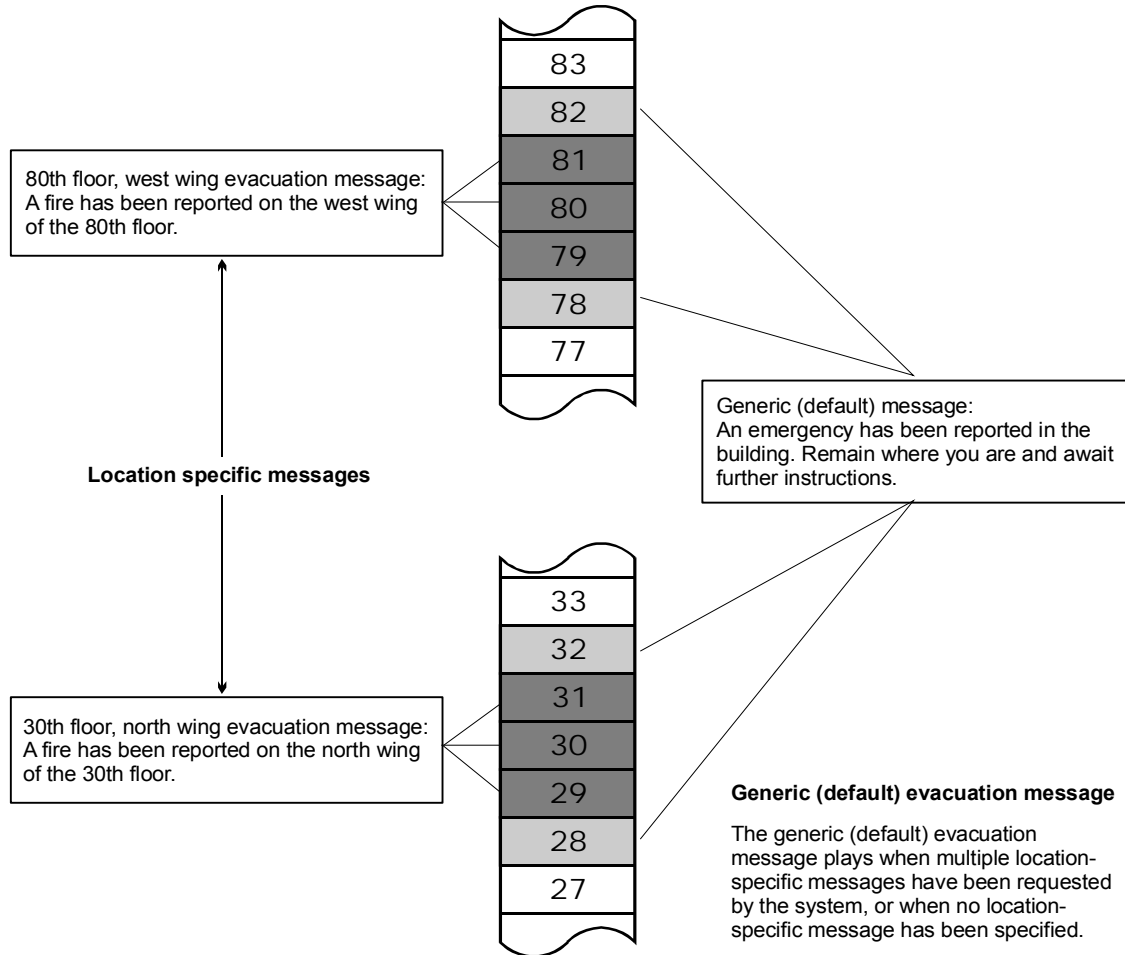

Figure 1-9: Automatic Message Processing

Firefighter phone

The 3-FTCU contains a master telephone handset that provides an analog telephone riser for totally independent 2-way communications between the fire command station and Firefighter telephone stations / jack telephones installed at strategic locations throughout the protected facility.

Taking a telephone off-hook or plugging into a telephone jack generates a visual and audible incoming call signal at the fire command station. The individual originating the call hears a tone until the handset is connected to the system. The fire command station operator manually connects the incoming phone call to the phone riser to complete the call. Up to five remote telephones may be connected to the riser simultaneously. The fire command center operator can also use the telephone circuit as a page source, permitting paging via the telephone system.

Digital network subsystem

Network data riser wiring

The network data riser provides the communication path between each CPU module (3-CPU_x or 3-ANNCPU_x) installed in the system. Each CPU module has two bi-directional RS-485 ports (Network A and Network B) that are used to connect the network data riser wiring. Network B is isolated from ground and Network A is not.

The correct method for running the network data riser is to connect the isolated Network B port on one CPU module to the non-isolated Network A port on another. Any remote CPU modules connected to a local CPU module's Network B port is considered to be *downstream* from the local CPU module. Any remote CPU modules connected to a local CPU module's Network A port is considered *upstream* from the local CPU module.

Additionally, *next* and *previous* refer to the order in which remote CPU modules are electrically connected to a local CPU module. *Previous* refers to the remote CPU module whose isolated Network B port connects to the local CPU module's non-isolated Network A port. *Next* refers to the remote CPU module whose non-isolated Network A port connects to the local CPU module's isolated Network B port.

Note: Since the data traveling the network data riser is bi-directional, *out* and *in* references are used to direct wire connections.

Class B network data risers

In a Class B network, a break or short in the network data riser wiring divides the network into separate independent networks. Panels on the same side of the line fault will communicate with each other but not with panels across the line fault. Figure 1-10 shows the wiring for a Class B network.

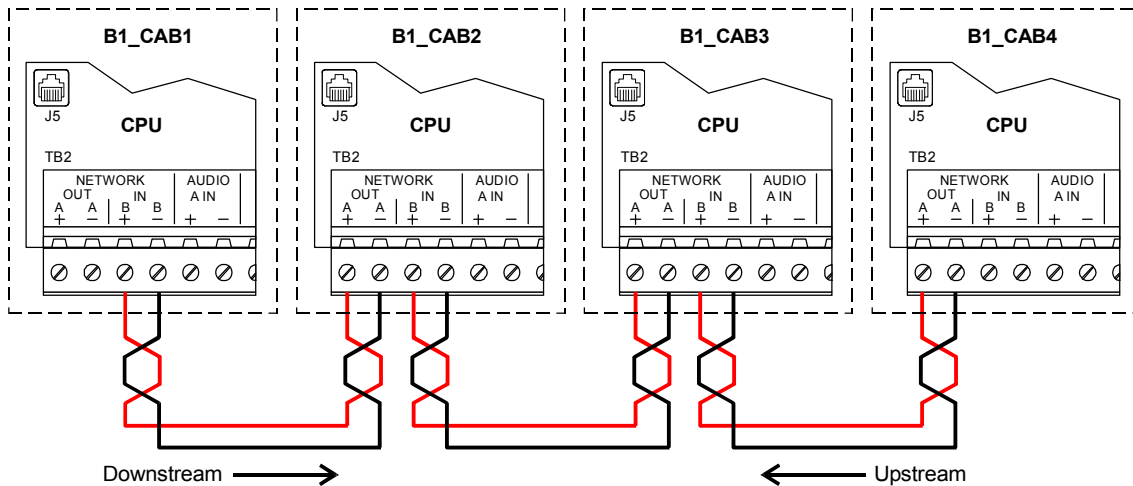

Figure 1-10: Class B network data riser wiring using copper wire

Note: As a matter of convention, a Class B network data riser should start at the CPU module that does not have wires connected to its Network A port.

When wiring a Class B network, give careful consideration as to the location of the service panel. The service panel provides a single point from which you can download files to all other panels on the network. For this function to work properly you must use the panel at the start of the network data riser as the service panel. See “Downloading data files” for more information.

Class A network data risers

In a Class A network, a single break or short in the network data riser wiring does not interrupt communications between panels. Figure 1-11 shows the wiring for a Class A network.

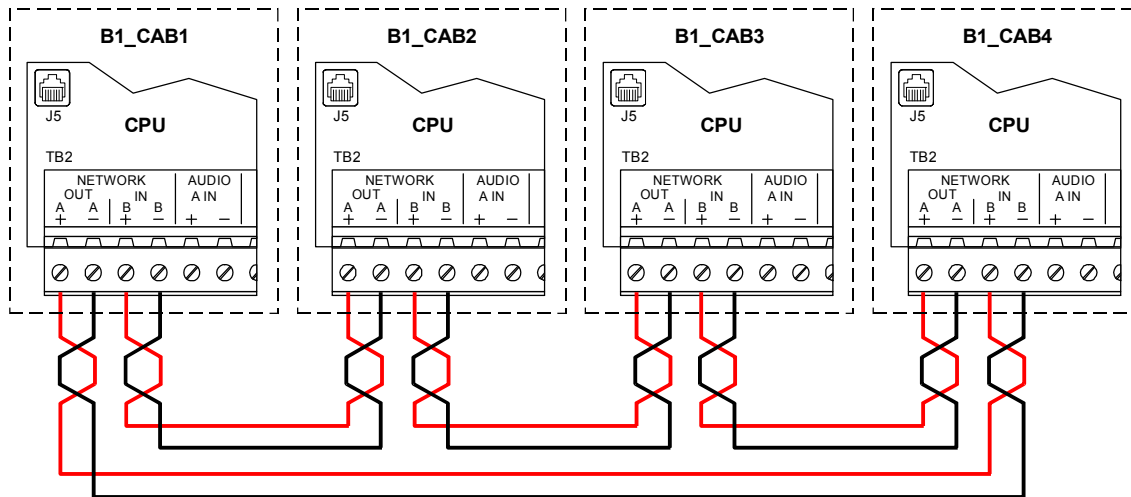

Figure 1-11: Typical Class A network data riser wiring using copper wire

Download connections

Each programmable rail module has a modular phone jack to use for downloading data directly from the SDU computer. The modular phone jack on any CPU module can also be used to download data to other programmable rail modules in the same panel over the rail bus, or to other panels over the network data riser.

In addition to the modular phone jack, the CPU module has two serial communication ports that can be used to download data, provided both of these conditions are met:

- A 3-RS232 option card is installed
- The serial port used to download data is not configured for gateway or coder applications

Tip: To download data over the network without having to reconfigure the system, temporarily install a 3-RS232 option card on any CPU module in the system and connect the SDU computer to serial port 1.

Connect here to download data to all three programmable rail modules over the rail bus (network mode) or to this programmable rail module only (single-step mode)

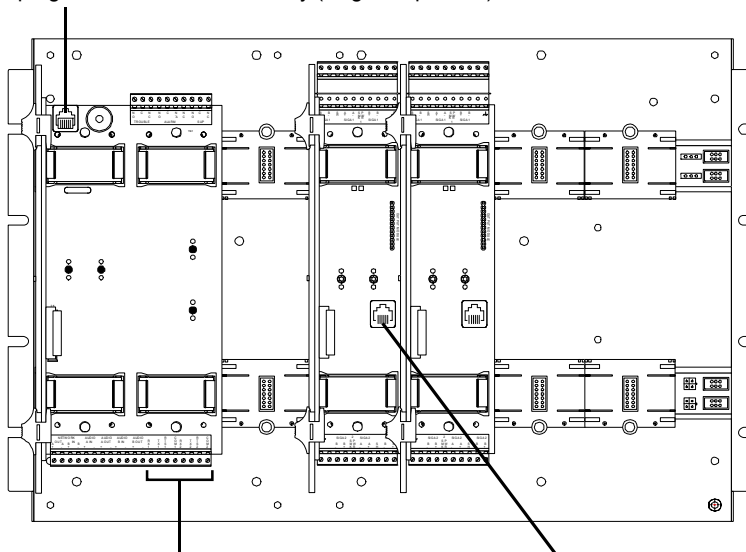

Optional serial ports may be used to download over the network (3-RS232 required)

Connect here to download data to this programmable rail module only (single-step mode)

Figure 1-12: Potential connection points for downloading data

Downloading database files over the network

A CPU module's Network A port and its modular phone jack share an interrupt with the module's microprocessor. As such, the microprocessor disables the Network A port whenever you connect the SDU computer to the modular phone jack.

Consequently, download options differ for Class A and Class B networks.

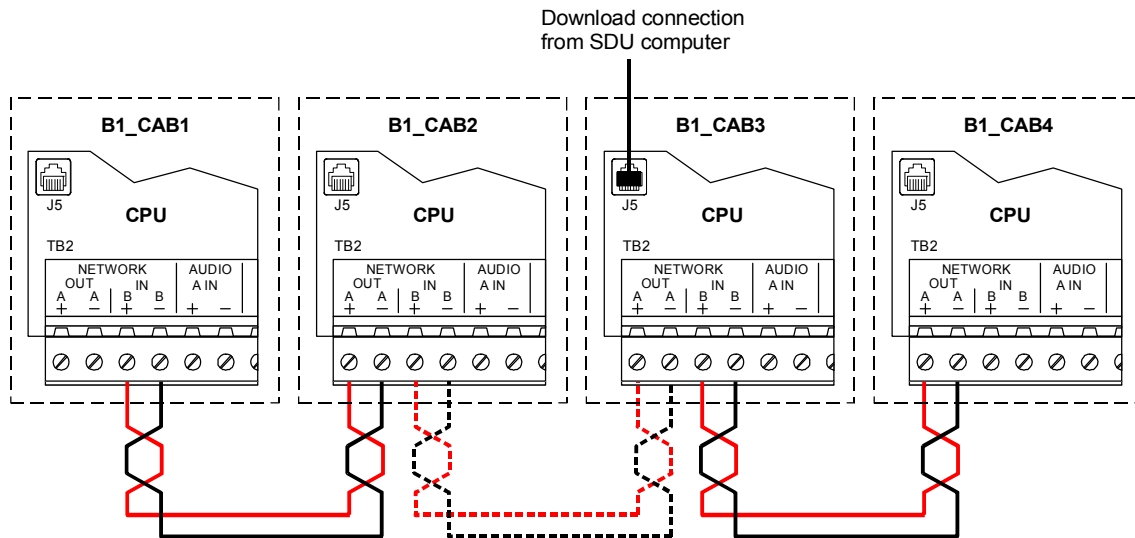

Figure 1-13: Impact of disabling Network A terminal connection on Class B networks during a download

Figure 1-13 shows how connecting the SDU computer to the modular phone jack affects downloading data over a Class B network. Connecting the SDU computer to the modular phone jack on the CPU module installed in panel B1_CAB3, disables that CPU module's Network A port. Downloading data to panels B1_CAB2 and B1_CAB1 from panel B1_CAB3 is no longer possible but downloading to B1_CAB4 still is.

Since the microprocessor disables only the Network A port, the CPU module that doesn't have a Network A port connection should be used as the service panel. It is the only panel that is capable of downloading to every panel on the network using the modular phone jack.

Note: Connecting the SDU computer to an optional serial communications port does not affect the Network A port. If a 3-RS232 option card is connected to the CPU, you can download data to any panel on a Class B network regardless of where the panel physically connects to the network data riser.

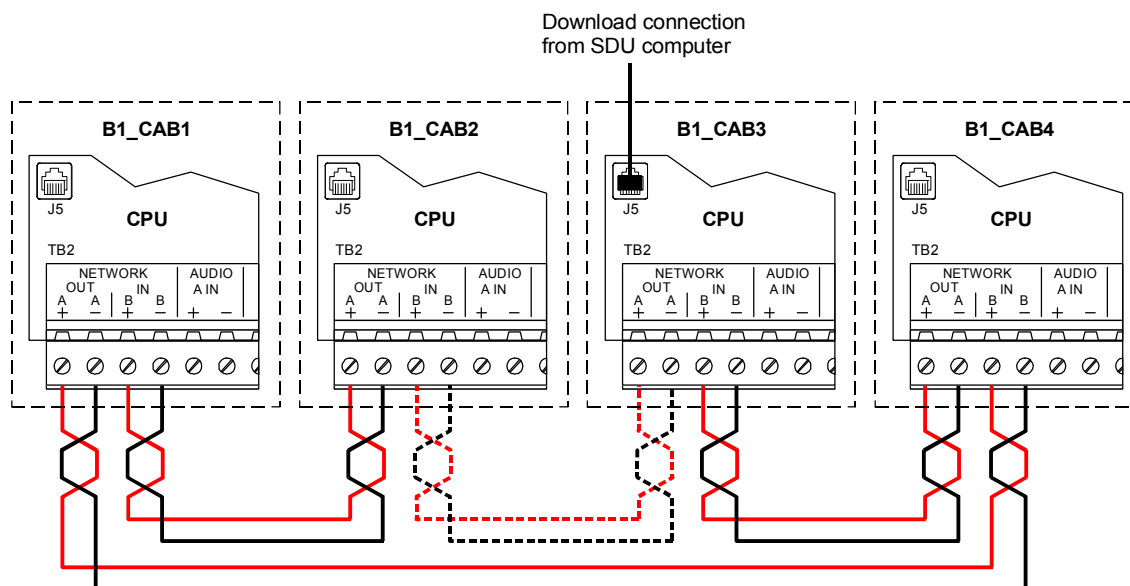

Figure 1-14: Impact of disabling Network A terminal connection on Class A networks during a download

On Class A networks however, see Figure 1-14, disabling the Network A port on panel B1_CAB3 does not prevent the other panels from receiving data through B1_CAB3's Network B port. Connecting the SDU computer to the modular phone jack does cause the panel to report a Network Class A Failure trouble. When the network data riser is configured for Class B, connecting to the panel modular phone jack causes the local CPU module to report a communications fault with every panel upstream of the local CPU module.

Tip: To download data to every panel across the Class B network data riser, connect to the first connection on the network data riser as the download panel — the panel with no connections on its Network A terminals.)

Foreign language support

Printer use with foreign languages

When supporting a single-byte character set language, your printer must be able to support the appropriate DOS code page. To support a double-byte character set language, your printer must be able to support the appropriate Windows code page. The required code pages are listed below.

Remember that not all Windows characters are available on DOS printers, so some characters are not supported on these printers.

Language	Code page
Chinese simplified	Windows Page Code 936 (GB)
Chinese traditional	Windows Code Page 950 (Big 5)
Korean	Windows Code Page 949 (Extended Wansung)
Hebrew	DOS Code Page 862
Turkish	DOS Code Page 857
Dutch, French, Italian, Portuguese, Spanish, English	DOS Code Page 850
Polish, Slovak	DOS Code Page 852
Russian	DOS Code Page 866

Bilingual language support

EST3 display modules (all LCD models and the KPDISP) feature bilingual operation. For two languages to be supported simultaneously, they must appear on the same code page. Refer to the table below to determine the system bilingual capabilities. Bilingual operation is not supported for Chinese and Korean.

Windows code page	Languages supported
1250 (Eastern Europe)	English, Polish Slovak
1251 (Cyrillic)	English, Russian
1252 (Western Europe)	Dutch, English, French, Italian, Portuguese, Spanish
1254 (Turkish)	English, Turkish
1255 (Hebrew)	English, Hebrew

Example: Bilingual operation between Polish and Slovak is supported (code page 1250). Bilingual operation between Polish and Russian is not supported, as no code page has both.

Display device language support

LCD language support

Language	Marketplace				
	US	European	Asian	Canadian	Mideast
Chinese, traditional (Taiwan)			X		
Chinese, simplified (PRC)			X		
Dutch		X			
English (UK)		X			
English (US)	X	X	X[1]	X	X
French Canadian	X			X	
Hebrew	X			X	X
Italian	X	X		X	
Korean, Extended Wansung			X		
Polish		X			
Portuguese (Brazil)	X			X	
Russian	X	X		X	
Slovak		X			
Spanish (South America)	X			X	
Turkish	X			X	

[1] For testing and support purposes only

3-FTCU language support

Language	Marketplace				
	US	European	Asian	Canadian	Mideast
Chinese, traditional (Taiwan)			[1]		
Chinese, simplified (PRC)			[1]		
Dutch		X			
English (UK)		X			
English (US)	X	X	X	X	X
French Canadian	X			X	
Hebrew	X			[1]	[1]
Italian	X	X		X	
Korean, Extended Wansung			[1]		
Portuguese (Brazil)	X			X	
Spanish (South America)	X			X	
Turkish	[1]			[1]	
Russian	[1]	[1]		[1]	
Polish		[1]			
Slovak		[1]			

[1] Only Western European character set is supported

KPDISP language support

Language	Marketplace				
	US	European	Asian	Canadian	Mideast
Chinese, traditional (Taiwan)					
Chinese, simplified (PRC)					
Dutch		X			
English (UK)		X			
English (US)	X	X		X	X
French Canadian	X			X	
Hebrew	X			X	X
Italian	X	X		X	
Korean, Extended Wansung					
Polish		X			
Portuguese (Brazil)	X			X	
Russian	X	X		X	
Slovak		X			
Spanish (South America)	X			X	
Turkish	X	X		X	

Signature series devices

The Signature series family consists of intelligent smoke and heat detectors, bases, input/output modules, and ancillary devices. The EST3 network supports Signature series devices using several models of the Signature Driver Controller module. Up to 125 detectors and 125 modules can be connected to the Signature Data Circuit on these modules.

The Signature series smoke and heat detectors contain their own microprocessors. This allows the devices to make alarm decisions based on the information gathered by the sensing elements incorporated in the device. Signature series detectors can be installed in any of four detector bases:

- The Standard Base provides wiring terminals for connection to a remote LED.
- The Relay Base provides a detector activated, pilot-duty dry contact relay used to control external appliances.
- The Sounder Base incorporates a sounder horn that can be controlled by the detector, by a special Signature module, by the control panel, or by programmed rules
- The Isolator Base protects the Signature Data Circuit from wiring shorts.

Signature modules interface and support the operation of initiating devices, conventional 2-wire smoke and heat detectors, manual pull-stations, strobes, bells, etc. The actual functions of each Signature module is determined by a personality code downloaded to the module through the System Definition Utility (SDU) program.

Signature series manual pull-stations (1-stage and 2-stage) feature an integral Signature module that monitors the station. One-stage stations are monitored by a single input module that sends an alarm signal to the loop controller when the station is activated. Two-stage stations are monitored by a dual input module which sends two independent alarm events to the control panel; one when the pull-switch is activated, and the second when the key switch is activated.

Alarm sensitivity setting

Alarm sensitivity refers to the primary threshold (expressed in percent smoke obscuration) at which the smoke detector will go into alarm. The alarm sensitivity setting for smoke detectors can be set to one of five sensitivity levels. When smoke detectors having both ionization and photoelectric elements are used, the sensitivity setting applies to both elements. Reduced sensitivity settings are used to reduce the occurrence of nuisance alarms.

The alarm sensitivity setting may be individually set for each detector using the SDU program.

Alternate alarm sensitivity setting

Alternate alarm sensitivity refers to the secondary threshold (expressed in percent smoke obscuration) at which the smoke detector goes into alarm. The alternate alarm sensitivity setting for smoke detectors can be set to one of the same five sensitivity levels as the primary alarm. When smoke detectors having both ionization and photoelectric elements are used, the sensitivity setting applies to both elements. This feature permits increasing or reducing an individual detector's sensitivity at various times of the day, dependent upon, environmental conditions, occupancy, manufacturing processes, etc. Increased sensitivity is typically used when a facility is unoccupied. Reduced sensitivity is typically used to reduce the occurrence of nuisance alarms when occupancy or environmental conditions may create prealarm conditions. An alternate alarm sensitivity setting for each detector can be set using the SDU program.

Alarm verification

Upon receipt of the initial alarm signal from a verified detector, the EST3 panel issues a detector reset command. After a programmable reset/retard period, if the detector continues to generate an alarm during the fixed confirmation period, the alarm is considered valid and processed by the EST3 control panel. Alarm verification reduces the occurrence of nuisance alarms, as it provides a time frame in which the cause of the alarm can be investigated to determine whether an actual alarm condition exists. The alarm verification period can be increased or decreased through the SDU program, as limited by the listing agencies.

Alternate alarm verification

The alternate alarm verification feature operates the same way the alarm verification feature operates using a second, alternate, programmed reset/retard period.

Prealarm setting

Signature smoke detectors can be configured to enter a prealarm state, which generates a monitor event message. Detectors configured for prealarm have a prealarm pseudo point for which rules can be written.

During configuration, you specify a percentage of the alarm sensitivity setting that will generate a prealarm event.

Alternate prealarm setting

The alternate prealarm setting is similar to the prealarm setting, but it represents a percentage of the alternate alarm sensitivity that will generate a prealarm event.

Network applications

This section deals with the initial layout of the network cabinets as well as application configurations for the basic network modules.

Network layout

The first task for the system designer is locating the equipment cabinets throughout the project. The objective when locating cabinets is to maximize the per cabinet coverage of the facility while minimizing hardware cost. The following general information should be used as a guide to designing the system.

The per cabinet coverage is, in some part, based upon the type of project being designed. In a high rise building installation that requires an audio emergency voice communication system, the problem becomes how many floors can be served by a single cabinet. In a campus style installation, there may be one or more cabinets per building, depending on building size.

Cabinet coverage

The following factors govern how much area a single cabinet can cover:

Cabinet capacity: Depending on the installed equipment, the largest backbox available can have 21 module spaces and 3 chassis spaces. Is this enough cabinet capacity to house the equipment required to cover the proposed area?

Available current per cabinet: Does the proposed number of large current components (audio amplifiers and 24 Vdc notification appliance circuits), in addition to the required module currents, exceed the available 28 amps per cabinet or 60-Ah battery capacity?

Notification Appliance Circuit voltage drop: Does the distance from the cabinet to the last strobe, horn, speaker, etc. exceed the acceptable limits?

User interface requirements: Depending on the installed equipment, the largest backbox available can have 19 module displays installed. Will this provide enough capacity for the required control/display module functions?

Distance between cabinets: Does the wiring length between any three cabinets exceed 5,000 ft. (1,524 m)?

System capacity of 64 cabinets per network: Does the proposed system require more than 64 cabinets?

Cost of installation labor and materials: Is it cheaper to install a smaller cabinet and service the floor above and below the floor

of installation, or install a larger cabinet with more equipment, and wire two floors above and two floors below the cabinet floor?

Feature/function domain

The EST3 life safety system utilizes peer-to-peer networking technology. No single cabinet is in control of the network. Peer-to-peer networking permits multiple control locations within a single network. The feature/function domain is defined as the group of cabinets that are affected when the feature or function is activated. A network cabinet may be a part of one or more groups. Multiple control locations are permitted for any group.

Three types of domains are available.

Local: The feature/function affects only the cabinet on which the LCD module is installed.

Group: The feature/function affects a predefined group of cabinets on the network.

Global: The feature/function affects all the cabinets on the network.

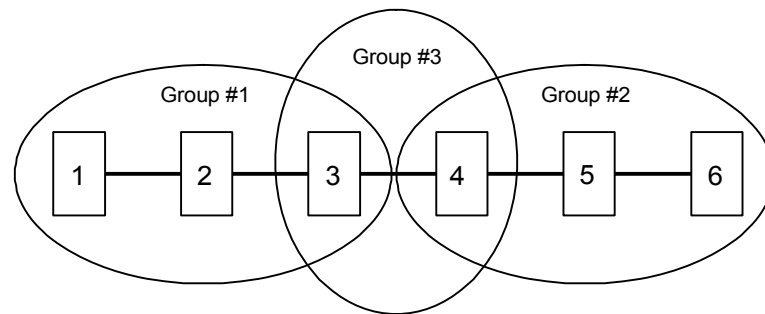

Figure 1-15: Sample domain consisting of three groups

Using the System Definition Utility (SDU), you can configure the system so that information from any cabinet can be selectively sent to any combination of other cabinets on the network.

Each cabinet may selectively transmit the following information to other cabinets on the network:

- Reset commands
- Alarm Silence commands
- Trouble Silence commands
- Drill commands
- Acknowledge commands

A cabinet can also be configured to receive state changes (Alarm, Supervisory, Trouble, Monitor, firefighter telephone incoming calls), logicals, events, audio controls, and so forth, from a select group of cabinets.

Feature/function domains are associated with the cabinet providing the operator controls. In Figure 1-15, the feature/function domain for Cabinet 1, which has the operator controls for the first subnet, is groups 1 and 3. The feature/function domain for Cabinet 6, which has the operator controls for the second subnet is groups 2 and 3.

Two subnetworks, with operator controls at cabinets 1 and 6.
Cabinets 3 and 4 are common to both subnetworks.

	Sending cabinet	Cabinet state	Commands				Acknowledge
			Reset	Alarm silence	Trouble silence	Drill	
Group 1	Cabinet 1	1, 2, 3, 4	1, 2, 3, 4	1, 2, 3, 4	1, 2, 3, 4	1, 2, 3, 4, 5, 6	1, 2, 3, 4
	Cabinet 2	1, 2, 3, 4	N/A	N/A	N/A	N/A	N/A
Group 3	Cabinet 3	1, 2, 3, 4, 5, 6	N/A	N/A	N/A	N/A	N/A
	Cabinet 4	1, 2, 3, 4, 5, 6	N/A	N/A	N/A	N/A	N/A
Group 2	Cabinet 5	3, 4, 5, 6	N/A	N/A	N/A	N/A	N/A
	Cabinet 6	3, 4, 5, 6	3, 4, 5, 6	3, 4, 5, 6	3, 4, 5, 6	1, 2, 3, 4, 5, 6	3, 4, 5, 6
Legend 1 through 6 = Cabinets that receive commands from the sending cabinet N/A = Not applicable							

Figure 1-16: Routed network commands for the domain illustrated in Figure 1-15

In Figure 1-16, the Cabinet 1 entry under the Cabinet State column indicates that Cabinet 1 should receive from cabinets 1, 2, 3, and 4 all information about changes of state. Because Cabinet 1 is the location of the operator controls it should send information about reset, alarm silence, trouble silence, drill, and acknowledgments to all the cabinets in the domain, which are cabinets 1, 2, 3, and 4. In this example, the drill command is common to both systems. Note, that the drill command is also sent to cabinets 5 and 6 by Cabinet 1.

The Cabinet 2 entry under the Cabinet State column indicates that Cabinet 2 receives its change of state information from cabinets 1, 2, 3, and 4. Because there are no operator controls located at cabinet 2, there is no need to send reset, alarm silence, trouble silence, drill, and acknowledgment information to other cabinets. As an alternative, the table could show these commands sent to other cabinets, because they can never be issued due to the lack of an LCD module in the cabinet.

Cabinets 3 and 4 receive their change of state information from all cabinets on the network, as indicated in the cabinet state column. This is necessary as cabinets 3 and 4 are part of both domains. Again, there is no need to send reset, alarm silence, trouble silence, drill, and acknowledgment information to other cabinets from cabinets 3 and 4.

The Cabinet 5 entry under the Cabinet State column indicates that Cabinet 5 receives its change of state information from cabinets 3, 4, 5, and 6.

Cabinet 6 information indicates that Cabinet 6 should receive from cabinets 3, 4, 5, and 6 all information about changes of state. Because cabinet 6 is the location of the operator controls it should send information about reset, alarm silence, trouble silence, drill, and acknowledgments to cabinets 3, 4, 5, and 6, (all the cabinets in the domain.) In this example, the drill command is common to both systems. Note, that the drill command is also sent to cabinets 1 and 2 by Cabinet 6.

Audio applications

Amplifier selection

The EST3 system provides amplifiers with 20-, 40-, and 95-watt output ratings to meet any project requirement. Selection of the proper amplifiers requires an understanding of the amplifier characteristics and application related information that follows.

Audio zoning

The output of each amplifier usually covers a single audio zone, typically a floor of a high rise building. Using the appropriate Signature modules, the amplifier's output can be divided into several zones. The output circuit can be configured for either Class A or Class B wiring.

Output wattage

The output rating of an amplifier is determined by the speaker load it is required to drive, and any expansion or safety factor required. The speaker load is determined by adding up the value of all the wattage taps selected on each speaker connected to the amplifier. For a conservative approach, use the highest wattage tap available on each speaker. This insures there is enough head room to adjust speaker taps to compensate for any installation variables such as sound absorbing furniture, etc.

Output voltage

Zoned amplifiers are available with either a 25 Vrms or 70 Vrms output. The 25 Vrms output amplifiers are primarily used in retrofit applications that previously had 25 Vrms speakers installed. 70 Vrms output amplifiers are recommended for new installations. The output circuits of a 70 Vrms amplifier can be run eight-times farther than a 25 Vrms amplifier, given the same load.

Note: If all the system wiring is required to be power limited, you may use any 20-, 40-, or 95-watt amplifier with either a 25 Vrms or 70 Vrms output.

Wiring considerations

Refer to Appendix B of this manual for wire distance calculations and other wiring considerations.

Backup amplifiers

Each cabinet can contain 1 zoned amplifier module to use to back up the remaining primary zoned amplifier modules installed in the same cabinet with the following restrictions:

- All the amplifiers must have the same output voltage rating.
- If the cabinet contains older amplifier modules (15- and 30-watt) and newer amplifier modules (20- and 40-watt), the amplifier used to back up the primary amplifier modules must be of the older type.

Note: In cases where older and newer zoned amplifiers exist in the same cabinet, the older modules should be replaced with newer modules for optimum results.

- The backup amplifier must have an output wattage rating equal to or greater than the largest primary amplifier it is backing up. If not, the output capacity of the speaker circuit is diminished proportionately.
- The wire used to wire the backup amplifier to the other amplifiers must be the same size or greater than that used to wire the speaker circuit.

Cabinet space

The 20- and 40-watt amplifiers each require one space on the rail assembly. The 95-watt amplifier requires two rail spaces.

The number of zoned amplifier modules that can be installed in a single cabinet is limited by the number of available rail spaces, the number of power supplies installed in the cabinet, and battery limits, if any.

Audio channels

The EST3 audio system provides eight (8) simultaneous channels for distribution of audio signals. The functions of four of these channels are fixed by the system. These four channels are referred to by their functions: *Page*, *EVAC*, *Alert*, and *Auxiliary Input* channels. The four remaining channels are referred to as general channels 1 to 4.

Under manual or automatic network control, each amplifier's input can be connected to either the Alert channel, the Evacuation (EVAC) channel, the Page channel, the Auxiliary Input channel, or one of four (4) general input channels. Should conflicting commands be issued to a single amplifier, the amplifier responds to the channel with the highest priority. The eight channels are prioritized as follows, with the Page channel having the highest priority

Page channel

Paging is a manual function. An operator is required to select a destination for the page, and then make an announcement. The Page channel is never automatically selected by the EST3 system.

The page channel always carries a live page signal, regardless of its source. There are three sources which can supply the paging signal: 1) the local 3-ASU microphone, 2) the remote microphone, and the 3) the firefighter telephone system. These sources are automatically prioritized as shown in Table 1-2.

Table 1-2: Page priorities

Priority	Page signal source
1 (highest)	Local microphone
2	Firefighter phone
3 (lowest)	Remote microphone

The page command is a non-latching function. When the page command ends, amplifiers automatically switch back to the source channel that was active (if any) prior to the page command.

Five types of page commands are available on the network. The first four page commands are available simply by pressing a single switch on the front of the 3-ASU. These are the paging functions most commonly used in an emergency situation.

1. The All Call command temporarily transfers all amplifiers to the Page channel while the page is active. All Call distributes the page signal to every amplifier in the system.
2. The Page to EVAC command temporarily transfers the Page signal to all amplifiers actively connected to the EVAC channel. All “EVAC” amplifiers then receive and distribute the Page signal.
3. The Page to Alert command temporarily transfers the Page signal to all amplifiers actively connected to the Alert channel. All Alert amplifiers then receive and distribute the page signal.
4. The All Call Minus command temporarily transfers the page signal to all amplifiers except those connected to the EVAC and Alert channels.
5. A Selective Page temporarily transfers the selected amplifiers to the Page channel while the page is activate, distributing the page signal only to selected audio zones

(amplifiers). Audio zones are selected manually by the operator using the LED/Switch displays.

An example of how the page commands work is illustrated in Figure 1-17. This figure shows a nine story high rise building, with a fire on the 6th floor. The fire plan requires the evacuation signal to be sounded on the fire floor, floor above the fire, and floor below the fire. The alert signal is required to be sounded in all other areas of the building except the stairwells. The first column (Fire Alarm) shows the automatic responses on the affected floors according to the fire plan.

Floor	Fire Alarm	ASU page commands				
		Page to Evac	Page to Alert	All Call Minus	All Call	Zoned Paging
Stairwells				<i>Page</i>	<i>Page</i>	
9th floor	Alert	Alert	<i>Page</i>	Alert	<i>Page</i>	Alert
8th floor	Alert	Alert	<i>Page</i>	Alert	<i>Page</i>	Alert
7th floor	Evac	<i>Page</i>	Evac	Evac	<i>Page</i>	Evac
6th floor	Evac	<i>Page</i>	Evac	Evac	<i>Page</i>	<i>Page</i>
5th floor	Evac	<i>Page</i>	Evac	Evac	<i>Page</i>	Evac
4th floor	Alert	Alert	<i>Page</i>	Alert	<i>Page</i>	Alert
3rd floor	Alert	Alert	<i>Page</i>	Alert	<i>Page</i>	Alert
2nd floor	Alert	Alert	<i>Page</i>	Alert	<i>Page</i>	Alert
1st floor	Alert	Alert	<i>Page</i>	Alert	<i>Page</i>	Alert
Legend ■ Fire floor □ Floor above or floor below fire						

Figure 1-17: ASU Page Command Example

The Page to EVAC command replaces the EVAC signal with the Page signal, as shown in the figure's second column.

The third column shows the Page to Alert command response, all the Alert signals have been replaced by the Page signal.

The All Call Minus command directs the Page to the areas which are not receiving the EVAC or Alert signals, i.e. the stairwells. In the fourth column of Figure 1-17, the stairwells receive the Page signal when the All Call Minus command is used and do not automatically receive either the EVAC or Alert signals.

The All Call command directs the page signal to all areas of the building, as illustrated in the last column of Figure 1-17.

Any combination of floors and stairwells could be selected to receive the page by manually selecting the audio zones on the audio zone select control/display module. Notice that at no time does any area receiving a signal have its signal interrupted by any page command function.

Evacuation (EVAC) channel

The EVAC channel always carries a signal designed to notify the occupants they must leave the facility. The evacuation signal may take the form of a textual message, a variety of audio tones, or an audio tone modulated by the standard 3-3-3 evacuation pattern, or any combination of these signals.

The EVAC channel is preprogrammed, and activated by the system in response to an alarm. The EVAC signal is automatically sent to the areas that are in danger and require immediate evacuation.

The EVAC channel has priority over all channels signals except for the Page channel. The alarm silence function automatically silences the EVAC channel when an operator presses the Alarm Silence switch.

Alert channel

The Alert channel always carries a signal designed to notify the occupants that an emergency situation exists in the facility. Occupants hearing the alert signal are not in immediate danger, but should prepare to evacuate. In some installations, the alert signal advises occupants that persons evacuating the danger area will be entering the area for safety.

The Alert channel is preprogrammed, and activated by the system in response to an alarm. The Alert signal is automatically sent to areas that are not in immediate danger and do not require immediate evacuation.

The Alert channel has priority over all other channels except the Page and EVAC channels. The alarm silence function automatically silences the Alert channel when an operator presses the Alarm Silence switch.

General channel

The General channel is used to distribute special purpose signals to special areas in the facility. Typically these areas include elevator cabs, stairwells, and areas in less peril than those areas receiving the Alert signal.

The general channel signals can be preprogrammed in response to an alarm, or they may be manually activated.

General channels have a lower priority than the Alert channel. The alarm silence function does not automatically silence the Alert channel unless programmed to do so.

Manual audio zone selection

If manual audio zone selection is required on the system, the appropriate control/display modules must be mounted on modules in the same cabinet as the Audio Source Unit. Typical configurations of control/display modules is shown in Figure 1-18. Exact operation of each display is dependent on system programming. Typical operation is described below.

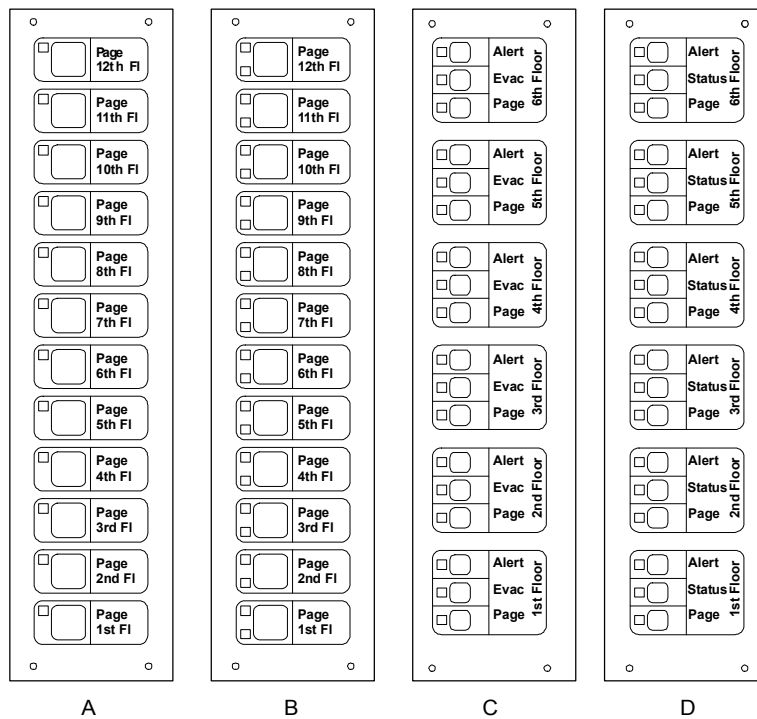

Figure 1-18: Audio zone selection displays

Display A is a model 3-12SG. Each floor switch provides audio zone selection for the Page signal, and the integral green LED indicates the audio zone is selected.

Display B is a model 3-12GY. Each floor switch provides Page audio zone selection. The green LED to the upper left of the switch indicates the audio zone is selected. The yellow LED to the lower left of the switch indicates audio circuit trouble.

Displays C and D are model 3-6/3Sxxx. The display C configuration permits manual selection of the Alert, EVAC, and Page signals by floor. This configuration is well suited for systems which do not sound signals through the entire facility during an alarm. Responsible authorities can then manually add EVAC and Alert signals to other floors of the facility. Display configuration D is used in facilities which sound the Alert signal in all areas not receiving the EVAC signal. This eliminates the need to switch the Alert signal. The middle switch is not used, the middle LED indicates amplifier status.

Messages

General

While there is no standardization on message content, messages must tell the occupant what is happening, why it is happening, and what actions they should take.

As a rule, each message should be repeated three times. If there is more than one language spoken in the area, the messages should be provided in each language.

A male voice has been demonstrated to be more authoritative than a female voice, and should be used where urgency is required. A female voice has been shown to initially gain the public's attention quicker than a male voice.

Alarm message format

The basic alarm message format consists of an alarm tone followed by an evacuation message repeated three times. The suggested alarm tone can take the form of a 1000 Hz tone modulated by the standard 3-3-3 evacuation pattern, a slow whoop, an electronic bell, a constant tone, or a constant tone modulated at a 120 pulse per minute rate. Please refer to the Authority Having Jurisdiction for specific requirements.

Typical Alarm Message text:

Female Voice: "May I have your attention please. May I have your attention Please." Male Voice: "There has been a fire reported in the building." "Proceed to the nearest stairwell and exit the building." "Do not use the elevators." "Repeat, do not use the elevators."

Note: The EST3 amplifiers operate in a stand-alone mode should they lose communication with the Audio Source Unit. The alarm tone used in the alarm message should be the same tone used by the amplifier for stand alone alarm signaling.

Alert message format

The basic alert message consists of an alert tone followed by an advisory message. The suggested alert tone should be easily differentiated from the alarm tone and can take the form of a constant tone, or a constant tone modulated at a 20 pulse per minute rate. Please refer to the Authority Having Jurisdiction for specific requirements.

Typical Alert message text:

Female Voice: "May I have your attention please. May I have your attention Please." Male Voice: "There has been an emergency reported in the building." "Your area is in no immediate danger." "People from other areas of the building may be entering your area." "Be prepared to leave the building if you hear the evacuation signal." "Repeat, you are in no immediate danger."

Informative messages

Informative messages are those special purpose signals to areas of the facility which may have special concerns during an emergency situation. Typically these areas include elevator cabs, stairwells, and areas in less peril than those areas receiving the Alert signal. Some sample informative messages appear below.

Elevator message text:

Female Voice: "May I have your attention please. May I have your attention Please." Male Voice: "There has been an emergency reported in the building." "The building manager has directed the elevators to the lobby." "Please exit the building when you reach the lobby."

Stairwell message text:

Female Voice: "Please continue down the stairs to your assigned re-entry floor or the lobby." "Do not attempt to use the elevators."

Do Not Enter message text:

Male Voice: "Do not enter this area." "This is not an exit." "An emergency has been reported in this section of the building." "Please exit the building using a marked fire exit."

Message and tone storage

The prerecorded messages and tone sequences are stored in a digital format in the 3-ASU Audio Source Unit internal memory. When the message and tone library exceeds two minutes in total length, a 3-ASUMX/32 Expansion Memory card must be installed in the 3-ASU. The 3-ASUXM/32 provides additional storage space for up to 32 minutes of messages.

Messages and tone sequences are created and downloaded directly into the Audio Source Unit using the SDU and a computer equipped with a compatible sound card.

Firefighter phone system

Five phone off-hook limit

The circuitry on the 3-FTCU Firefighter Telephone Control Unit can support up to five telephones off-hook in addition to the master handset at the 3-FTCU at any one time. The flexibility of the EST3 system permits any number of phones to be wired on a single phone circuit, as long as they are not all used simultaneously. There are a number of different designs which can be used to insure that no more than five phones are active at any one time.

One phone per circuit

The advantages of installing a single firefighter phone station or jack on a SIGA-CC1 Signature module (personality code 6) are numerous. The system provides complete control and annunciation phone/circuit. Installing a single phone on a circuit permits the operator to immediately identify the exact location of the calling party. Because the 3-FTCU will only permit five circuits to be connected simultaneously, the maximum number of off-hook handsets can never be exceeded. Should a branch telephone circuit be damaged during a fire, the fault will not affect other phone circuits. When there is only one phone per circuit, troubleshooting of faults is simplified.

The largest disadvantage of installing one phone per branch telephone circuit is cost. Each phone location requires a separate SIGA-CC1 module.

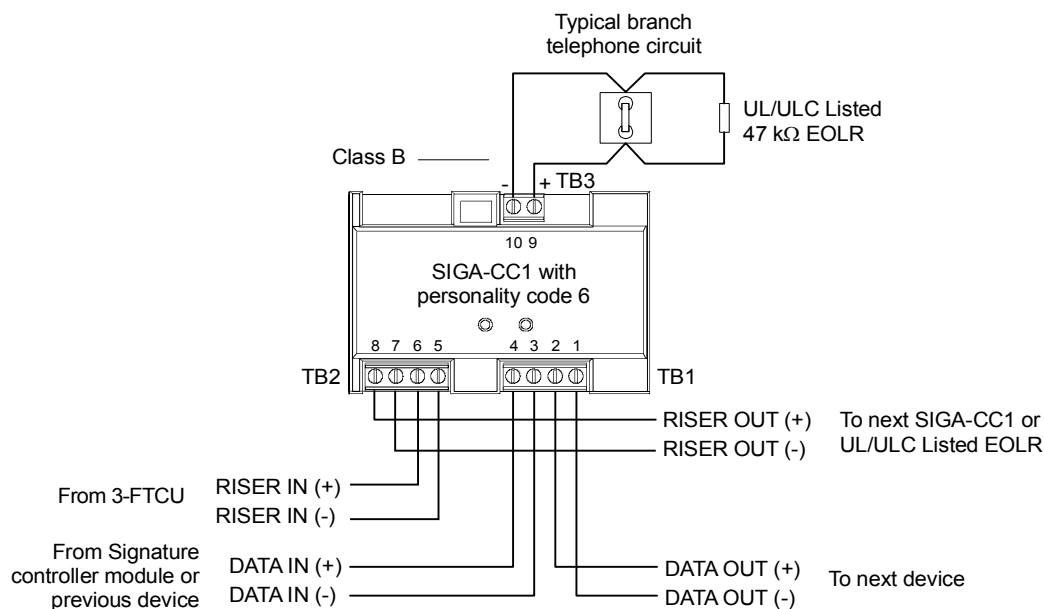

Figure 1-19: SIGA-CC1 with one phone installed

Five phones per circuit

Installing up to five phones per branch circuit is a realistic compromise between installing a single phone per circuit and more than five phones per circuit. In the rare instance that all five phones are off-hook and a need to communicate with a sixth remote phone arises, the 3-FTCU operator can temporarily disconnect the entire branch circuit. Then the second branch circuit can be connected to complete the conversation.

The advantages of installing up to five telephone stations or jacks on a SIGA-CC1 Signature module (personality code 6) are: a reasonable balance between cost and performance; and the system maintains the high quality voice circuit at all times because the maximum number of off-hook handsets can never be exceeded.

The main disadvantage of installing up to five phones per branch telephone circuit is that a circuit failure can render the entire branch circuit useless. Additionally, the location of the incoming caller is not precisely known, and troubleshooting is more difficult.

Limited number of portable telephone handsets

Another method of limiting the number of off-hook phones to five limits the number of available portable phones available to the fire department to five. The biggest advantage of this method

is low cost, as multiple remote telephone jacks can be installed on a single branch circuit.

The main disadvantage of this method are: that five phones may not be adequate to properly cover the facility; a circuit failure can render many of the phone jacks useless; the location of the incoming caller is not precisely known; and troubleshooting is more difficult.

Summary

EST3 has powerful and flexible security capabilities. This chapter introduces you to the equipment required for security systems.

This chapter also illustrates and describes several security applications. Each application is presented as a separate topic that includes a block diagram and description. These give you an overview of the application, and show the components required and their interconnection.

Refer to the *EST3 Installation Sheets* for specific component settings and terminal connections.

Content

- Security equipment • 2.2
- Certificate installations • 2.8
- Multiple 3-MODCOM modules • 2.13
- Multiple site security and access • 2.14
- Multiple tenant security • 2.17
- Secure access • 2.21

Security equipment

Introduction

The equipment required for a general security system is shown in Figure 2-1. We'll discuss each item shown in the drawing, plus the *other factors* called out on the drawing.

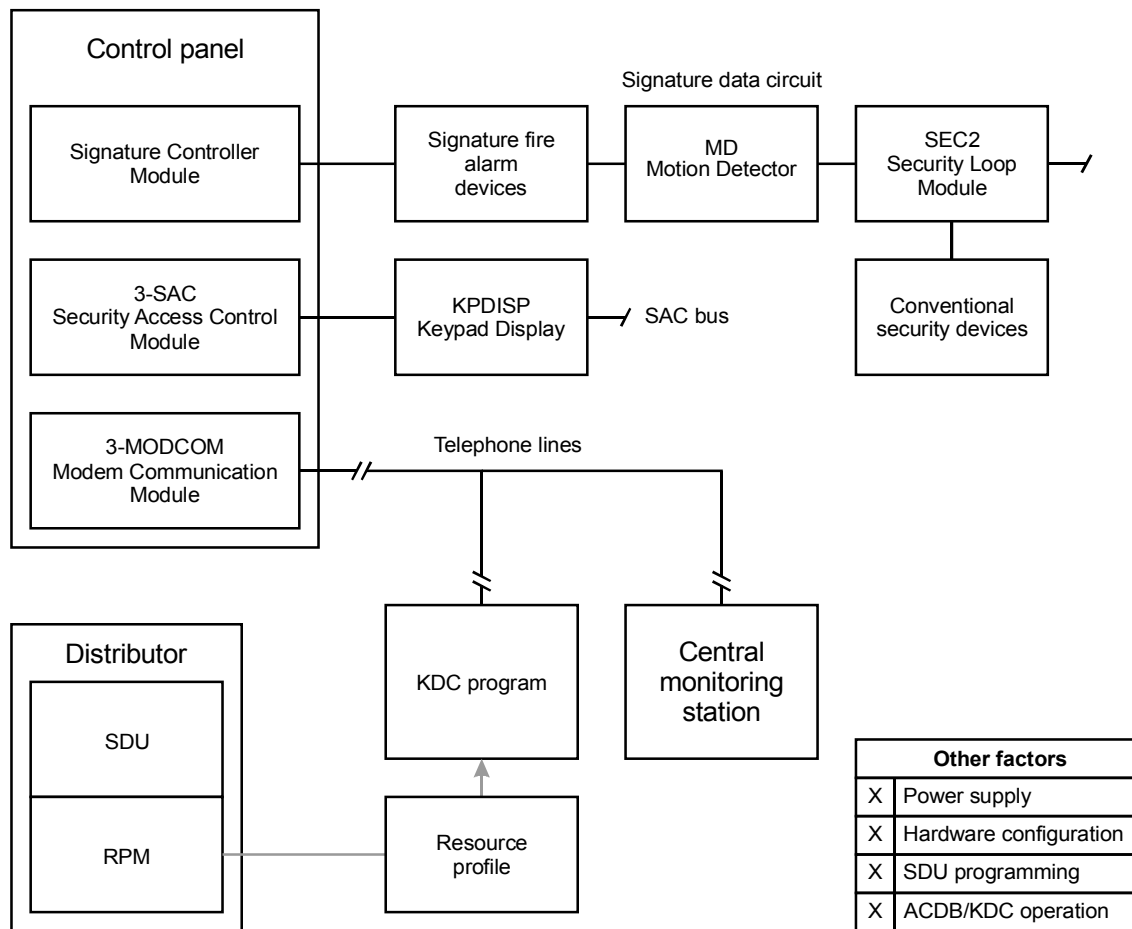

Figure 2-1: Equipment required for a basic security system

Equipment

The equipment used in security applications includes:

- Control panel
- Signature Controller module
- SIGA-MD Motion Detector module
- SIGA-SEC2 Security Loop module
- 3-SAC Security Access module
- SAC bus

- KPDISP Keypad Display
- 3-MODCOM Modem Communication module
- RPM Resource Profile Manager tool
- KDC Keypad Display Configuration program

Control panel

It is a UL listing requirement that all cabinets in a system that includes security functions must have a tamper switch. The control panel must include a 3-TAMP, 3-TAMP5, or 3-TAMPRCC Cabinet Tamper Switch.

Signature Controller module

The Signature data circuit plays a dual role in integrated systems. First, it supports devices and modules belonging to the fire alarm system. Second, it supports security devices that are part of the security system.

Figure 2-1 shows a Signature Controller module with a Class B Signature data circuit. Shown on this circuit are Signature fire alarm devices, plus two security devices, the SIGA-MD and the SIGA-SEC2.

Several Signature Controller models are available, and can be used with integrated systems.

Note: Security devices can also be installed on the SAC bus via CRCs, or on an analog device loop.

SIGA-MD Motion Detector module

The SIGA-MD is a passive infrared motion detector that connects to the Signature loop. The detector has alarm and tamper output monitoring capability. A contact closure causes an alarm but does not latch at the module.

The SIGA-MD provides six separate curtain coverage patterns with a 34-foot range. The detector can be mounted in flat corners or on walls up to a height of ten feet.

SIGA-SEC2 Security Loop module

The SIGA-SEC2 Security Loop Module is an intelligent analog addressable device that connects one or two security loops to a Signature data circuit. In Figure 2-1 this is indicated by the conventional security devices connected to the SIGA-SEC2.

The operation of the SIGA-SEC2 is determined by its device type and personality code. These are assigned during system design and configuration.

3-SAC Security Access Control module

The 3-SAC Security Access Control rail module controls a high-speed RS-485 circuit called the Security Access Control (SAC) bus. The SAC bus supports fire, security, and access control devices.

The 3-SAC handles message traffic for these devices, interfacing them with the CPU as required. Events are passed from the devices to the 3-SAC module, then to the CPU for alarm processing.

The 3-SAC has two sets of circuit terminals, and is capable of Class A or Class B configuration. Each Class B circuit can include 31 devices, for a total of 62 devices per module. Class A circuits can include 30 devices total. In the figure, we show a Class B bus with a KPDISP Keypad Display control and display module.

SAC bus

Since our security and access control devices require 24 Vdc, we suggest that you always use a four-wire cable (two twisted-pairs) for the SAC bus and a 24 Vdc power supply.

For the data wires we suggest unshielded, twisted pair, with greater than 6 twists per foot, in 14 to 22 AWG (1.50 to 0.25 sq mm).

For the power wires, we recommend 14 or 16 AWG.

KPDISP Keypad Display

The KPDISP Keypad Display is a control and display module for security and fire alarm systems. The KPDISP has an LCD display and a telephone-style keypad. It operates on the 24 Vdc power supplied with the SAC bus.

The KPDISP is completely menu-driven. It lets the system user:

- Arm and disarm partitions
- Review off-normal points
- Bypass or disable points
- Execute fire alarm panel commands

Each KPDISP stores its portion of the security database.

You can create a security system that is operated via the LCD module alone, or in combination with any Control/LED display module. See the topic “Secure access.”

Tip: To improve system performance in systems with a high number of partitions or cardholders, limit the volume of network messages. To do this, create partition routing groups so that only essential messages are sent to each KPDISP. In practice, limit the average number of partitions in a partition routing group to 10 or less.

3-MODCOM Modem Communicator module

The 3-MODCOM Modem Communicator module has both modem and dialer functions. It can transmit and receive information.

The 3-MODCOM can transmit alarm, supervisory, or trouble messages to a remote central monitoring station using one or two telephone lines. A variation of the module (3-MODCOMP) can transmit pager messages to a paging company using the TAP protocol. The 3-MODCOMP remote paging feature is supplemental and is not supervised.

The module can also receive information sent over telephone lines by the Keypad Display Configuration program.

RPM Resource Profile Manager tool

The Resource Profile Manager (RPM) tool is part of the SDU. It uses the project database to let you create a separate resource profile for each company that will be using the security system.

The resource profile defines the security system for the KDC program. It includes such information as:

- The KPDISPs in the system
- The routing required to access each KPDISP for downloads
- Which KPDISPs can execute fire alarm system commands

The resource profile is imported into the KDC program during installation.

KDC Keypad Display Configuration program

The Keypad Display Configuration (KDC) program lets the system user define and maintain a database of information about KPDISPs, users, and access levels. This is part of the overall security database.

The KDC program runs on the user's PC. Additions or updates to the security database can be transmitted to the KPDISP units in two ways.

The first method is via modem and dial-up telephone line to the 3-MODCOM. The information is then routed to the CPU, through the correct 3-SACs, and finally to the affected KPDISP units.

The second method is by connecting the user's PC directly to the CPU using an RS-232 cable. The connection is made between the PC's COM1 port and any of the RS-232 terminals on the CPU. As in the first method, after reaching the CPU additions and changes are routed through the correct 3-SACs to the affected KPDISPs.

Note: Fire and security functionality cannot be programmed into a control panel from a remote location. You must perform all panel programming on site. Changes to the security database have no impact on the parameters or operations of listed fire system equipment.

When the site includes an access control system, the Access Control Database (ACDB) program is used in place of the KDC. The ACDB includes the required KDC functionality.

Other factors

Next, we'll cover the additional factors listed on the drawing:

- Power supply
- Hardware configuration
- SDU programming
- ACDB/KDC operation

These factors are called out on each application diagram given in this chapter.

Power supply

The KPDISP is designed to operate on 24 Vdc. For this reason, we recommend that you include power from the panel with the SAC bus cable. You can use the panel 3-PPS/M, 3-BPS/M, or 3-BBC/M power supplies.

Note that additional power supplies must be listed for the application.

Hardware configuration

The KPDISP does not have any switch or jumper settings. All configuration is done with the SDU program.

SDU programming

While the KDC program controls a small portion of the security database, all other definition, configuration, and programming for the security system happens in the SDU.

The SIGA-MD and SIGA-SEC2 are both treated as modules on the Signature data circuit. You configure each security module using the SDU.

The SDU controls the general configuration of the 3-SAC modules, plus the configuration of all CRC or KPDISP devices on the SAC busses.

KPDISP modules can be configured to execute a specific, predefined command list when a specific security or access

control event occurs. You write the command lists in the SDU, and assign them to KPDISP events when you configure the KPDISP module.

Partitions are fundamental groups used with security systems. A partition is a group of devices intended to provide security for a given area of the site. Partitions can be armed and disarmed separately.

All partitions are created and defined in the SDU, and each CRC, CRC input circuit, KPDISP, SIGA-SEC2 circuit, and SIGA-MD circuit can be assigned to a partition. Partitions also play a role in KPDISP message routing.

For the 3-MODCOM module, the SDU determines the dialer and modem parameters, defines the receivers and accounts, and assigns each account to the correct receiver.

Finally, the SDU includes the RPM tool, described earlier in this topic.

ACDB/KDC operation

The Keypad Display Configuration (KDC) program runs on the end-user's PC. It lets him create and maintain a database of information about KPDISPs, users, and access levels. This is part of the overall security database.

During setup of the program, the user imports the resource profile created by the RPM during system programming.

Once installed, the user can create and revise his KDC database. Changes and additions are transmitted via modem to the 3-MODCOM or via direct RS-232 connection to the CPU. The data is then routed to the correct 3-SAC and KPDISP units.

Security applications

The remaining topics in this chapter cover specific security applications. Each topic gives you an overview of the application, and shows you the components required and their interconnection.

Each topic has a block diagram and general description of the application. Other factors (as called out on the drawings) are discussed under separate headings in each topic.

Certificate installations

Description of the applications

An installation company can be listed to install burglar alarm systems that are covered by UL under its Follow-Up Service. The listed company issues a certificate of the appropriate class, grade, and type.

This topic does not detail the steps required for certificate installations. You must follow UL 681 to determine the exact requirements for a given installation. Here, we simply list special EST3 equipment that can be used in the following applications:

- Central Station Alarm Certificate
- Police Station Connect Certificate
- Local Mercantile Alarm Certificate

Refer to Appendix C, “Listing requirements” for additional information.

Special equipment

Certificate installations require the use of specialized attack and tamper equipment. Here are brief descriptions of the special parts. The diagrams for each application show which parts are required.

ATCK Attack Kit: a replacement cover kit for the 3-RCC7 cabinet. The kit provides a two-minute attack delay time. It includes a red, overlapping box cover for the cabinet. The cover attaches to the backbox sides using sheet metal screws and four locks. The kit also includes special knockout plugs that secure the unused knockout holes.

3-TAMPRCC Cabinet Tamper Switch: a switch that detects removal of the cover.

Central station alarm certificate

Figure 2-2 shows the equipment that can be used as part of a Central Station Alarm Certificate installation. Note that this is the same equipment used for a Police Station Connect Certificate installation.

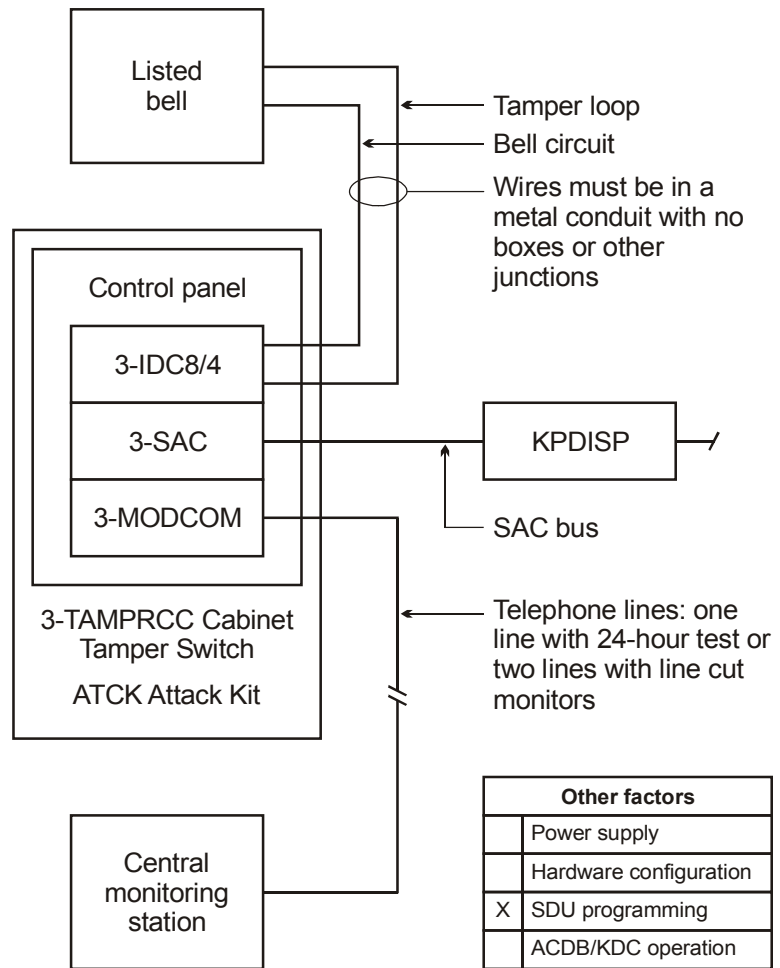

Figure 2-2: Components used with a central station certificate application

For this certificate, the control panel cabinet must be fitted with an ATCK Attack Kit and a 3-TAMPRCC Cabinet Tamper Switch. In addition, a listed local bell is required.

The bell must be positioned where it can be heard from every arming station in the system. You can use multiple bells if required.

The bell requires a tamper detection loop. Both the bell circuit and the tamper detection loop can be supported by a 3-IDC8/4 module.

A single phone line that is tested at least once in every 24-hour period can be used. Alternately, two lines with line cut monitoring can be used in place of a line with 24-hour testing.

If the central monitoring station (CMS) does not have testing services, the SDU can program the system to issue tests on a fixed or relative basis to meet this requirement.

The CMS must have a maximum response time of 30 minutes.

When this application includes partitions, the partition that contains the EST3 panel equipped with the 3-MODCOM and local bell must be armed 24 hours a day, and have limited, high-level access.

Police station connect certificate

The equipment, installation requirements, and application restrictions for a Police Station Connect Certificate installation are the same as for a Central Station Alarm Certificate installation, as described above.

Central station alarm certificate

Figure 2-3 shows the equipment that can be used as part of a Central Station Alarm Certificate installation.

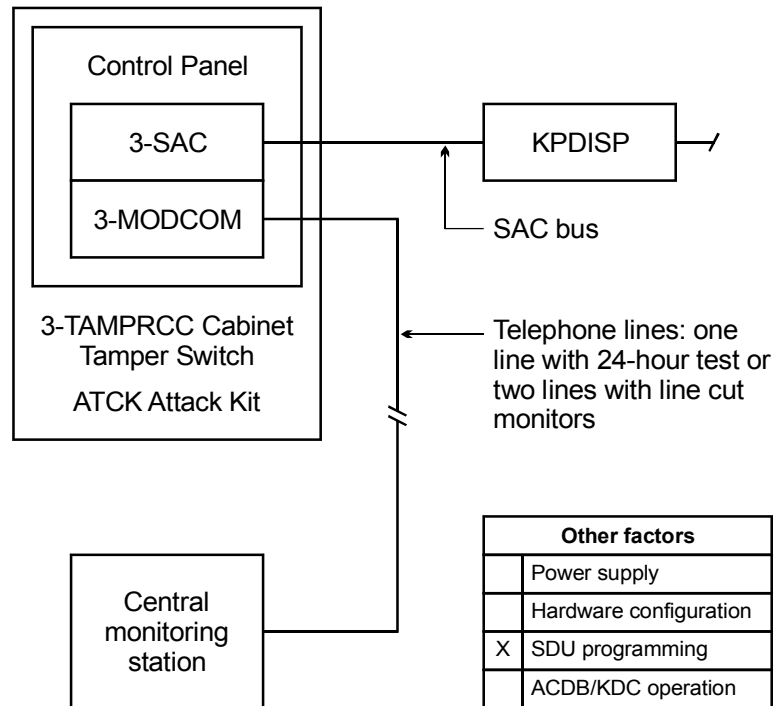

Figure 2-3: Central station certificate

This certificate requires that the control panel be fitted with an ATCK Attack Kit and a 3-TAMPRCC Cabinet Tamper Switch. No local bell is required.

A single phone line that is tested at least once in every 24-hour period can be used. Alternately, two lines with line cut monitoring can be used in place of a line with 24-hour testing.

When this application includes partitions, the partition that contains the EST3 panel equipped with the 3-MODCOM must be armed 24 hours a day, and have limited, high-level access.

In mercantile burglar alarm systems, you can locate an alarm sounding device outside the protected area, provided the sounding device is located inside the building, is rated for outside service, and you transmit alarm conditions to one of the following:

- The dispatch location of the law enforcement agency having jurisdiction over the protected property
- A central station or residential monitoring station complying with the Standard for Central Station Alarm Services, UL 827

You can also locate an alarm sounding device within the area of greatest protection, or outside the area of greatest protection within an area protected by an alarm system that shares a common control unit with the alarm system installed in the area of greatest protection, provided the sounding device is rated for inside service and you transmit alarm conditions to one of the following:

- The dispatch location of the law enforcement agency having jurisdiction over the protected property
- A central station or residential monitoring station complying with the Standard for Central Station Alarm Services, UL 827

In either case above, mount alarm sounding devices located inside building at least 10 feet (3.05 m) above the floor or at the surface of the ceiling. When there is fixed construction within the area that could provide access for an intruder, mount the alarm sounding device at least 4 feet (1.2 m) away from the edges of the fixed construction along the surface of the ceiling or at least 10 feet (3.05 m) above it so as to minimize access by an intruder.

Local mercantile alarm certificate

Figure 2-4 shows the equipment that can be used as part of a Local Mercantile Alarm Certificate installation. The control panel cabinet must be fitted with an ATCK Attack Kit and a 3-TAMPRCC Cabinet Tamper Switch. A listed local bell is also required.

The bell requires a tamper detection loop. Both the bell circuit and the tamper detection loop can be supported by a 3-IDC8/4 module.

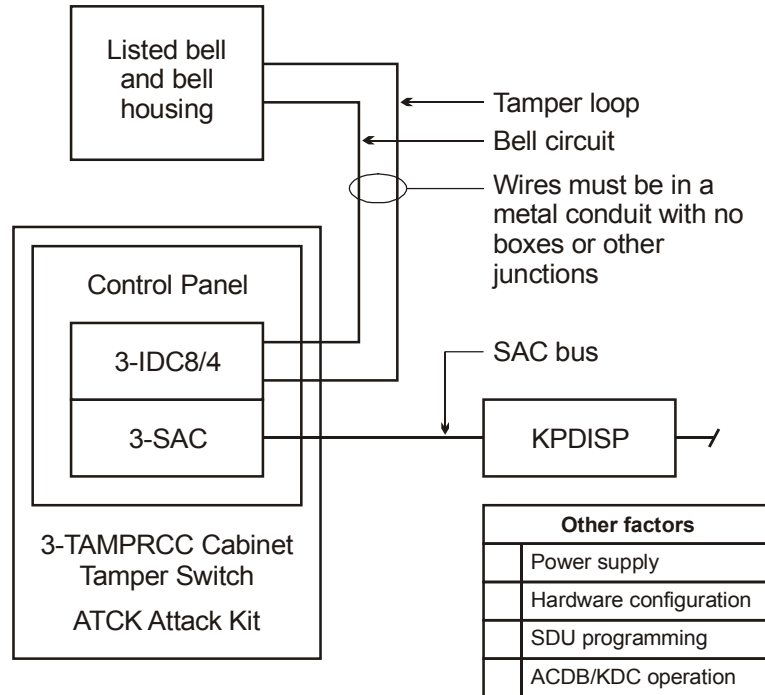

Figure 2-4: Local certificate

The bell must be positioned where it can be heard from every arming station in the system. You can use multiple bells if required.

In mercantile alarm systems that do not provide a remote alarm transmission connection, you must mount the alarm housing on the outside of the building in a location that is accessible, is not more than four stories above street level, and is visible from the public street or highway.

You may locate the alarm housing as high as the seventh floor, provided you do one of the following:

- Mount a second alarm sounding device and housing intended for outside service adjacent to the premises or area of the building in which the alarm system is installed
- Mount a second alarm sounding device and housing intended for inside service within the premises

Multiple 3-MODCOM modules

You can install more than one 3-MODCOM Modem Communicator module in a system. Two or more 3-MODCOM modules can be installed in the same cabinet. Two or more cabinets can contain 3-MODCOM modules.

There are several reasons for using multiple 3-MODCOMs:

- Redundant communication to a CMS
- Backup of critical communication links
- Dedicated security transmission hardware

In a redundant communication system both 3-MODCOMs are programmed to transmit the same message to different receivers at the CMS or at different CMS installations.

One 3-MODCOM can be programmed to back up another. This guarantees CMS communication (or TAP paging) should one panel in the system become disabled.

In a multiple tenant application, there may be a high volume of ACDB/KDC program traffic. You can design such systems with a second 3-MODCOM, dedicating the first module to ACDB/KDC traffic, and the second module to CMS transmissions. This prevents contention for communication channels.

Overall limits for the number of 3-MODCOM modules are:

- 10 modules per node
- 10 modules total per network

Multiple site security and access

Description of the application

Figure 2-5 shows how a company with multiple sites can centralize security and access control functions for all sites. This means an employee only needs to carry a single access card to gain appropriate access to any company site.

The figure shows a company with three plants, designated sites A, B, and C. Site C is chosen as the company headquarters for security and access control purposes.

Each site is a separate SDU project. At each site, the Resource Profile Manager (RPM) tool is used to create a profile for that site. This includes site C, the headquarters plant.

All the profiles are sent to the security office at site C for import into the Keypad Display Configuration (KDC) or Access Control Database (ACDB) program. This means that the programs will present all resources at all sites in a single hierarchy, as shown by the tree diagram.

The security personnel at site C can create global access groups. This means that they can assign an employee the correct security and access privileges for all sites from one central location. The employee can carry a single access card that will grant him the correct security and access privileges at each site.

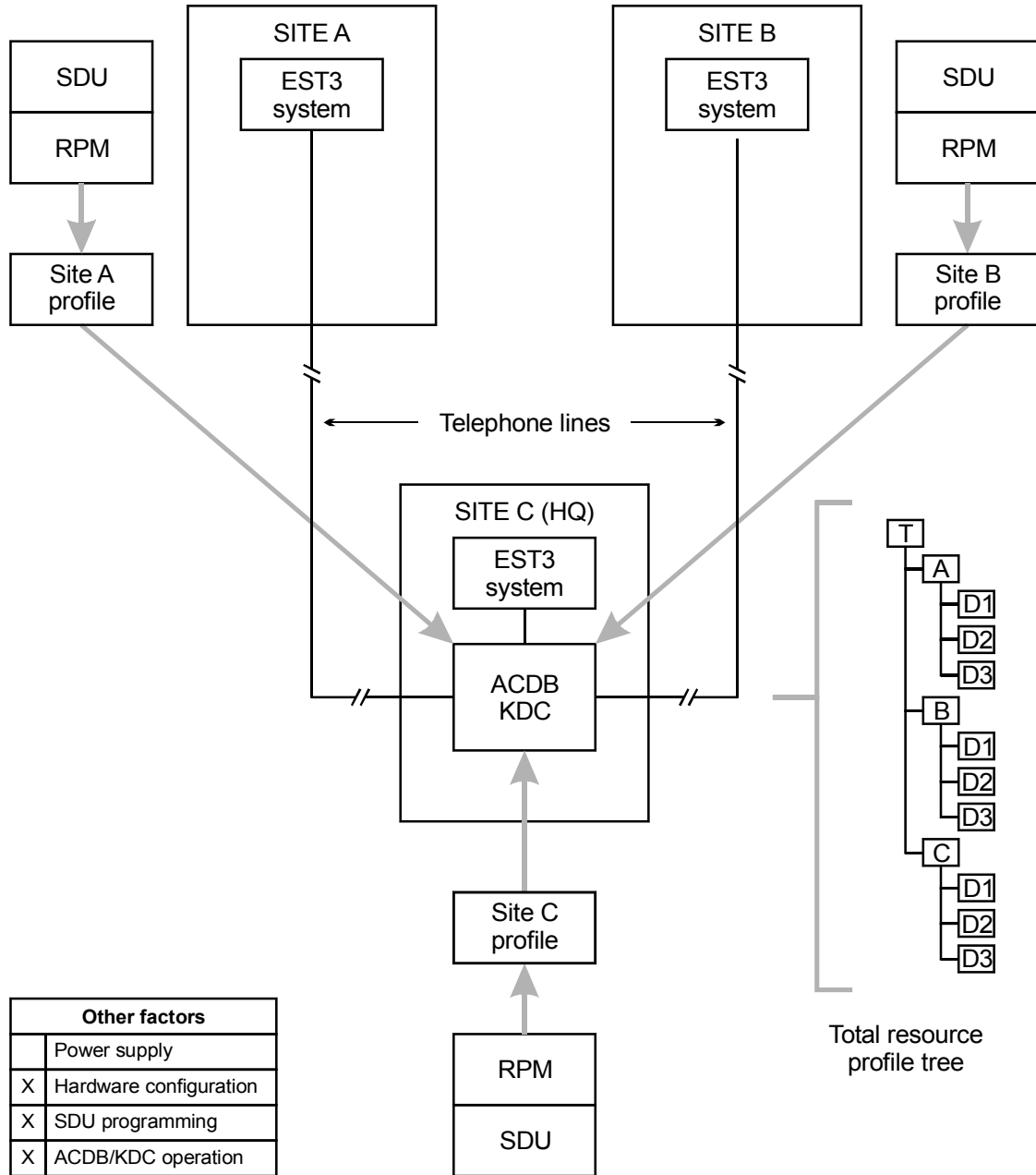

Figure 2-5: Multiple site security and access control system

Hardware configuration

Each site must have an EST3 system. In each EST3 system, at least one panel must include a 3-MODCOM module to support modem communication between headquarters and sites A and B.

The KDC and ACDB programs can communicate with the EST3 system either by modem, or by direct connection to an RS-232 port on the CPU module.

Each system includes 3-SAC modules as required to support the security and access control systems implemented.

Rules covering installation and classification (of extent) of alarm equipment at individual locations are published in the *Standard for Installation and Classification of Burglar and Holdup Alarm Systems* UL681.

SDU programming

No special project programming is required to enable multiple site security and access control systems. When running the RPM tool, each site receives 100% of the resources for that site.

Note that all profiles must be sent to the site C headquarters when the project is finished.

ACDB/KDC operation

At the headquarters site, all three profiles are imported into the ACDB/KDC program. The result is a global tree of resources that includes each KPDISP and CRC device in each site.

Importing all the profiles into one ACDB/KDC program creates the global database.

When additions or changes to the KPDISP database are made, headquarters can transmit the changes to the affected sites.

Multiple tenant security

Description of the application

Figure 2-6 illustrates a simple strip mall security application. The mall consists of three identical stores and an electrical room.

The control panel supports a SIGA data circuit and a SAC bus. The panel also supports modem communications via telephone lines.

The SIGA circuit has pull stations and smoke detectors. In addition, the SIGA circuit has two security devices, the motion detector and the SIGA-SEC2 security loop module. The SIGA-SEC2 connects a conventional door contact to the SIGA circuit.

The SAC bus is used exclusively for the KPDISP devices.

Each company owner has a Keypad Display Configuration (KDC) program. The program runs on a computer equipped with a modem, and uses the modem and a dial-up telephone line to communicate with the control panel.

Each company owner can use the KDC to download changes to that company's portion of the security database. The changes are routed through the panel to the appropriate KPDISP unit.

Note: Fire and security functionality cannot be programmed into a control panel from a remote location. You must perform all panel programming on site. Changes to the security database have no impact on the parameters or operations of listed fire system equipment.

The control panel can be configured to provide telephone connection to a central monitoring station (CMS). Each tenant company can have a separate account at the same CMS, or can use the services of a separate CMS.

Refer to Appendix C, "Listing requirements" for additional information.

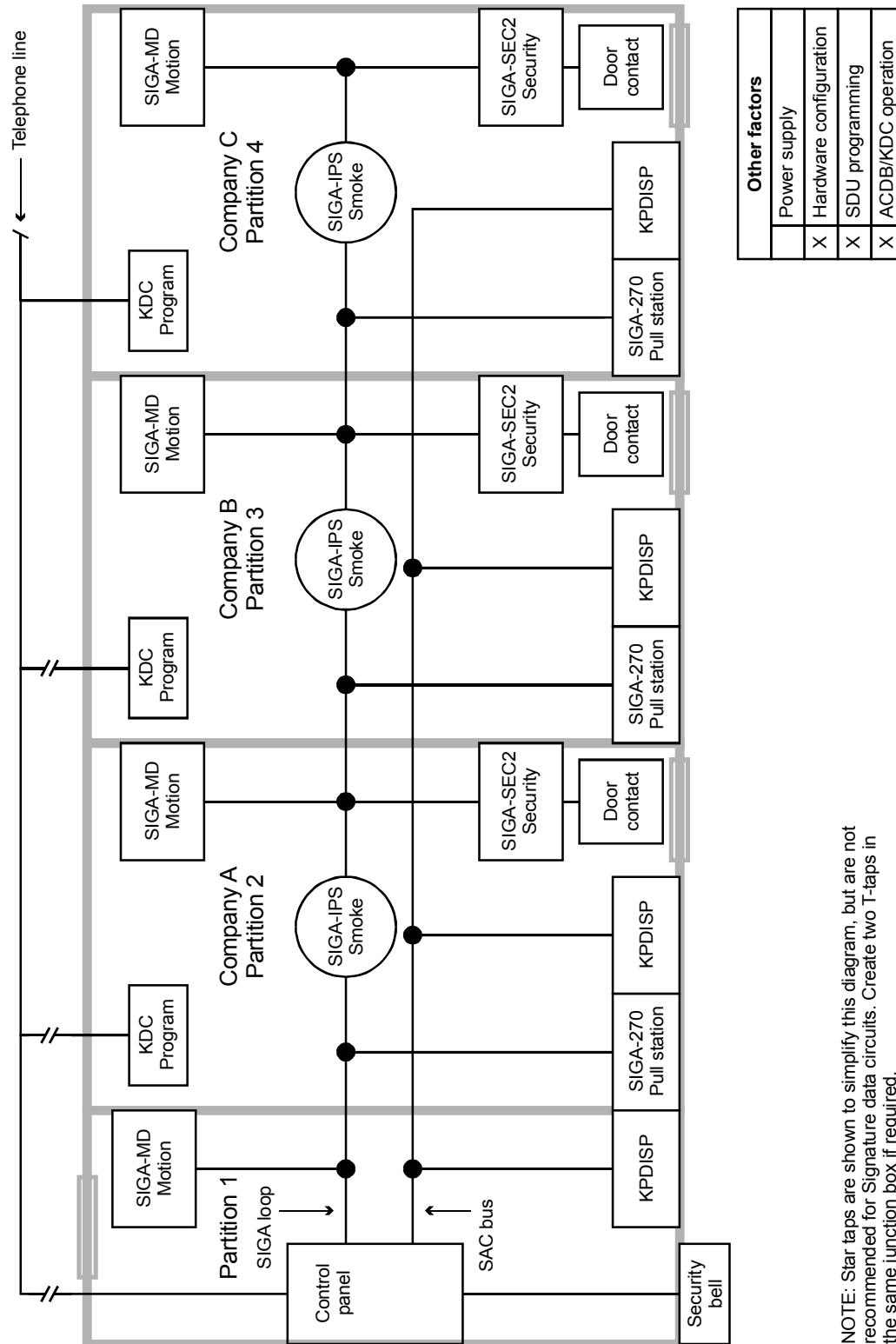

Figure 2-6: Multiple tenant security in a strip mall

Hardware configuration

The control panel contains the following rail modules:

- Signature Controller module
- 3-SAC Security Access Control module
- 3-MODCOM Modem Communicator module

The Signature Controller module supports the SIGA loop.

The 3-SAC module supports the SAC bus. Power for the KPDISP can be taken from the 3-PPS/M and routed with the data lines in a cable composed of two twisted-pair wires.

The 3-MODCOM module supports modem communication between the control panel and the KDC programs via telephone lines.

In the Class B configuration illustrated, an appropriate RS-485 line terminating resistor is required in the KPDISP located in partition 4.

The electrical room, partition 1, must be armed 24 hours a day, and have limited, high-level access.

SDU programming

When programming the system for this application, you define the required partitions and assign the correct partition number to each security device.

Part of the programming effort includes using the Resource Profile Manager (RPM) tool to create resource profiles for the site owner and for each company owner.

Since none of the devices are shared, each company should receive 100% of the resources of their KPDISP. A small percentage may be set aside for use of the site owner, depending on the owner's policy.

Programming for the 3-MODCOM module determines the dialer and modem parameters, defines the receivers and accounts, and assigns each account to the correct receiver.

Finally, when running the RPM tool, you specify which, if any, of the KPDISP modules can execute fire system commands. Typically, this privilege is reserved for the site owner or site security staff.

Refer to the *SDU Online Help* for more information.

KDC operation

Each company owner must import the resource profile output from the RPM. After importing this resource data, each company

owner can create his portion of the security database, according to the instructions included with the KDC program.

Changes to the tenant portion of the security database can be made at any time, and from any location.

Note: Fire and security functionality cannot be programmed into a control panel from a remote location. You must perform all panel programming on site. Changes to the security database have no impact on the parameters or operations of listed fire system equipment.

Secure access

Description of the application

Secure access is a simplified type of security application. Typical secure access applications are operated from a secured control panel, and use partitions with no entry or exit delay timers.

Secure access applications often use the control panel LCD module (or dedicated Control/LED display modules) to control the security partitions. Partitions can be armed or disarmed using any of the following:

- LCD menus
- EST3 Control/LED modules
- FireWorks interface
- ENVOY annunciators
- KPDISP

A secure access system can be implemented using either Signature or Analog Addressable security devices. Signature devices are less prone to false alarms, and are more resistant to tampering, since they cannot be swapped with deliberately compromised devices.

SDU programming

When you create a secure access application, use the SDU to create partitions as required. When configuring the partitions, set the Entry Delay Timer and Exit Delay Timer values to zero. When configuring SIGA-SEC2 and SIGA-MD devices, set the Delay to None.

You can use LCD menu commands to arm and disarm the partitions. To do so, you must check the Enable LCD Security Control Functions check box. This is located on the Options tab of the Cabinet Configuration dialog box. Checking this box causes the Security menu to appear in the Command Menus list.

You can use any suitable Control/LED module to arm and disarm partitions. Configure the switches as momentary contact switches, and use them to activate command lists. Program the command lists to perform the desired arm and disarm actions and control the LEDs.

Refer to the *SDU Online Help* for more information on rule programming for secure access applications.

Access control applications

Summary

EST3 supports rugged and adaptable access control systems. This chapter introduces you to the equipment required for access control applications.

This chapter also illustrates and describes several access control applications. Each application is presented as a separate topic that includes a block diagram and description. These give you an overview of the application, and show the components required and their interconnection.

Refer to the *EST3 Installation Sheets* for specific component settings and terminal connections.

Security applications make use of the CRC Card Reader Controller. Refer to the *CRC and CRCXM—Card Reader Controller Installation Sheet* for specific installation information on this module.

Content

- Access control equipment • 3.2
- Anti-passback • 3.11
- Central monitoring station • 3.14
- Common door access • 3.16
- Delayed egress • 3.18
- Elevator control • 3.21
- Emergency exit door • 3.24
- Handicap access door • 3.26
- Maglock peripherals • 3.28
- Multiple card readers • 3.30
- Muster • 3.32
- Power for continuous locks • 3.35
- Power for intermittent locks • 3.37
- Power from an AC source • 3.39
- Power from a remote source • 3.42
- Remote controls • 3.45
- Two-person rule • 3.47

Access control equipment

Introduction

The equipment required for a basic networked access control system is shown in Figure 3-1. We'll discuss each item shown in the figure, plus the *other factors* called out on the drawing.

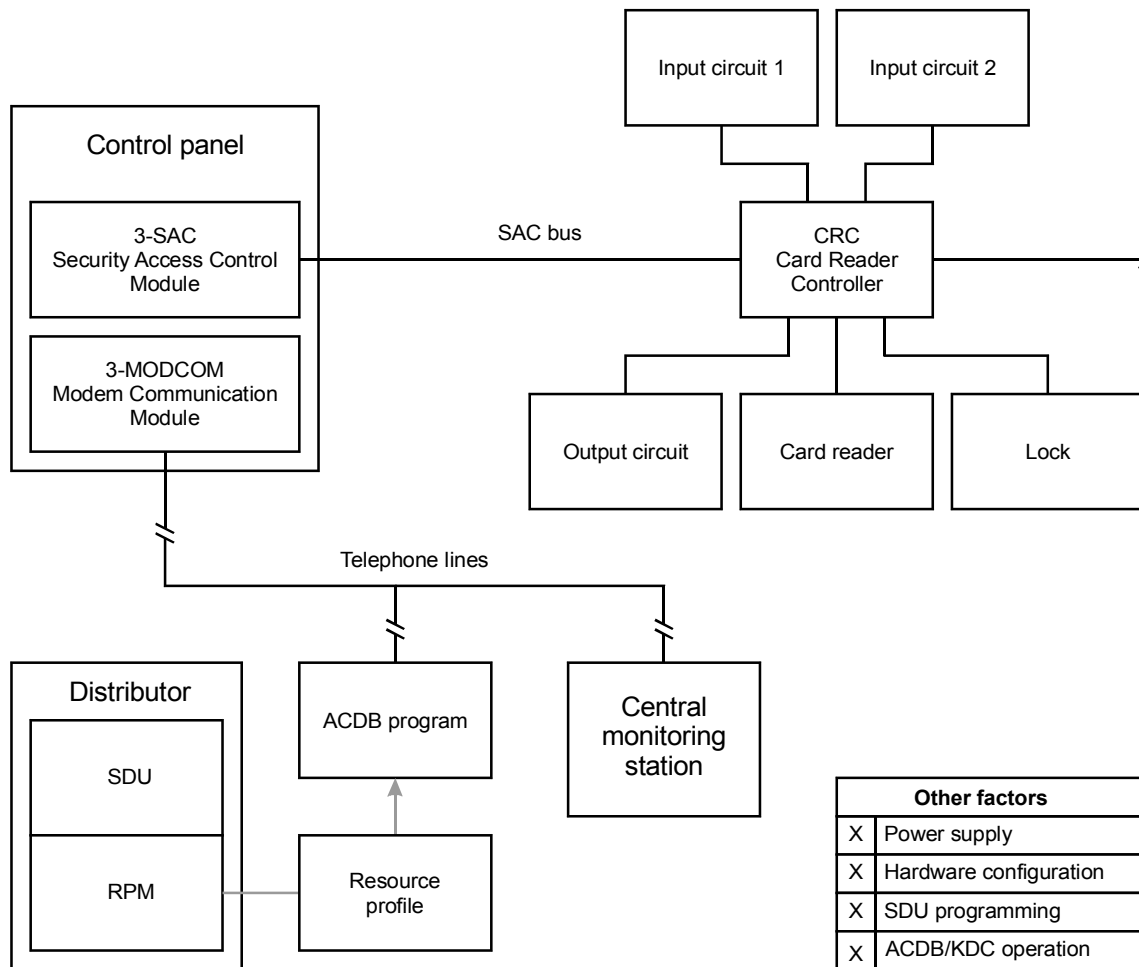

Figure 3-1: Equipment required for a basic access control system

Equipment

Here is a list of the equipment used in a basic networked access control system:

- 3-SAC Security Access Control module
- 3-MODCOM Modem Communication module
- SAC bus
- CRC Card Reader Controller

- Input circuit 1
- Input circuit 2
- Output circuit
- Card reader
- Lock
- RPM Resource Profile Manager tool
- ACDB Access Control Database program

3-SAC Security Access Control module

The 3-SAC Security Access Control rail module controls a high-speed RS-485 circuit called the Security Access Control (SAC) bus. The SAC bus supports fire, security, and access control devices.

The 3-SAC handles message traffic for these devices, interfacing them with the CPU as required. Events are passed from the devices to the 3-SAC module, then to the CPU for alarm processing.

The 3-SAC has two sets of circuit terminals, and is capable of Class A or Class B configuration. Each Class B circuit can include 31 devices, for a total of 62 devices per module. Class A circuits can include 30 devices total. In Figure 3-1, we show a Class B bus with a CRC Card Reader Controller module.

3-MODCOM Modem Communicator module

The 3-MODCOM Modem Communicator module has both modem and dialer functions. It can transmit and receive information.

The 3-MODCOM can transmit alarm, supervisory, or trouble messages to a remote central monitoring station using one or two telephone lines. A variation of the module (3-MODCOMP) can transmit pager messages to a paging company using the TAP protocol.

The module can also receive information sent over telephone lines by the Access Control Database (ACDB) program.

SAC bus

Since our security and access control devices require 24 Vdc, we suggest that you always use a four-wire cable for the SAC bus and a 24 Vdc power supply.

For the data wires, use unshielded, twisted pair, with greater than 6 twists per foot, in 14 to 22 AWG (1.50 to 0.25 sq mm). For the power wires, use 14 or 16 AWG.

You can use a four-conductor cable with an overall jacket containing solid 2-19 AWG and 2-16 AWG for the SAC bus.

The maximum run from a CRC to the 3-SAC is 4,000 ft (1,220 m) at 25 pF/ft. The maximum total capacitance of the run is 0.1 μ F, and the maximum total resistance is 52 Ω .

CRC Card Reader Controller

The Card Reader Controller (CRC) module performs all access decision processing. Each CRC stores a database and is capable of granting or denying entry without external communication. If entry is granted, the CRC applies or removes power to the strike or maglock to unlock the door. The CRC is also capable of unlocking a door by activating a manual push button.

Each CRC stores an access database of users and events for the door it controls. The CRCXM model features enhanced storage capacity. (Refer to the product installation sheets for quantities.)

Each CRC has terminals that support:

- Two card readers, typically one inside and one outside the door
- One lock device, either strike or maglock type
- Two input circuits for devices such as request to exit detectors, door contacts, or motion detectors
- One output circuit with N.O and N.C. contacts for auxiliary devices, such as door openers

With the addition of an internal battery, the CRC can continue processing access events even if there is a loss of communication or power.

CRC options

CRCSDND CRC Sounder

The CRC Sounder is a small horn that mounts inside the card reader controller module. The sounder operates if an emergency exit door is opened without an exit request and can also indicate that a door has been left open.

The CRC Sounder can be programmed, using rules written in the SDU. Further, the ACDB program can control several operating parameters of the sounder.

CRCRL CRC Accessory Relay

The CRCRL is an accessory relay for the CRC (or CRCXM) Card Reader Controller. Use the CRCRL in conjunction with an external power supply to control a lock which requires voltage or current outside the CRC's operating range.

The CRCRL can be mounted inside the CRC housing when connected to power-limited wiring. The unit includes a hook-and-loop patch which can be attached to the CRC battery strap.

When nonpower-limited wiring is used, the CRCRL must be mounted in a junction box.

The CRCRL is listed as an Access Control Accessory and Control Unit Accessory.

Battery

Each CRC has space for an internal, 1.2 Ah, sealed lead-acid battery. The battery supplies power to the CRC and its peripherals, and provides local standby power.

The CRC battery provides 30 minutes of standby power for access control functions and up to 4 hours for security functions. The battery cannot be used for fire applications.

CRCXF CRC Transformer

The CRCXF CRC Transformer is a 16.5 Vac transformer that can power the CRC or CRCXM. It provides local power for applications requiring additional power at door lock. The CRC has AC load terminals for easy connection to transformer.

Be sure to check the CRC installation sheet for a list of applications that prohibit the use of the CRCXF.

Input circuits 1 and 2

Each CRC supports two input circuits for such devices as:

- Door contacts
- Motion detectors
- Request to exit (REX) switches
- Security devices

A door contact device monitors the door position (open or closed) for various applications.

A motion detector detects a person's approach and can be used to unlock the door.

A request to exit (REX) push button (or bar) can be used to manually unlock the door.

Security devices, such as glass-break detectors can be associated with the door to enhance its security, or to monitor a nearby window.

Output circuit

Each CRC supports one output circuit in the form of N.O. and N.C. dry contact connections. The output circuit can be used for such devices as:

- Automatic door openers
- Door holder control

Card reader

By *card reader*, we mean any of the different types of credential reader supported by the CRC. A card reader scans a card to determine the card number and passes the card number to the CRC.

A card reader is a self-contained module capable of reading one type of access card and transmitting the card's code to a card reader controller.

All the required electronics are assembled in the card reader housing. The card reader connects directly to the CRC, which processes the card code and grants or denies access.

Each CRC can support several card readers. Typically, a CRC will control an entry and exit card reader for the doorway. It can also support multiple readers for such applications as two-person rule or anti-passback.

Note that the CRC supports any type of reader that uses the industry standard Wiegand output format. These include:

- Proximity
- Wiegand pin
- Magnetic stripe
- Bar code
- Keypad
- Smart card
- Biometric

For simplicity, we present all the applications in this chapter as operating with proximity readers, but other reader types can be used.

Some applications work best with card readers that support dual LED control. The CRC uses two LEDs, or two LED states, to indicate that further actions are required after the initial badging operation, before access is granted. These applications are:

- Two-person rule
- Visitor and escort
- PIN schedule

Some card readers are also equipped with a keypad. The keypad allows for entry of a PIN number in addition to the card code.

The CRC can accommodate any PIN number of 1-4 digits along with the associated card code. The need to enter a PIN is controlled by two factors: whether or not the CRC is armed, and whether or not the access schedule calls for use of a PIN.

Lock

The CRC supports any type of door locking or releasing device. Common lock devices are strikes and maglocks. A strike *opens* the door when power is supplied, while a maglock *secures* the door while power is supplied.

RPM Resource Profile Manager tool

The Resource Profile Manager (RPM) tool is part of the SDU. It uses the project database to let you create a separate resource profile for each company that will be using the access control system.

The resource profile defines the access control system for the ACDB program. It includes detailed information about each CRC used by a given company. For example:

- Communication method
- Primary or secondary control
- Number of cardholders
- Number of schedules
- Number of holidays
- Number of access levels
- Command lists used

ACDB Access Control Database program

The Access Control Database (ACDB) program lets you define and maintain a database of information about CRCs, cardholders, and access levels.

The ACDB program runs on the your PC. Additions or updates to the access control database can be transmitted to the CRC units in two ways.

The first method is via modem and dial-up telephone line to the 3-MODCOM. The information is then routed to the CPU, through the correct 3-SACs, and finally to the CRC units.

The second method is by connecting your PC directly to the CPU using an RS-232 cable. The connection is made between the PC's COM1 port and any of the RS-232 terminals on the CPU. As in the first method, after reaching the CPU additions and changes are routed through the correct 3-SACs to the CRCs.

Note: Changes to the access control database have no impact on the parameters or operations of listed fire system equipment.

Other factors

Next, we'll cover the additional factors listed on the drawing:

- Power supply
- Hardware configuration
- SDU programming
- ACDB/KDC operation

These factors are called out on each application diagram given in this chapter.

Power supply

The CRC is designed to operate on 24 Vdc. For this reason, we recommend that you include power from the panel with the SAC bus cable. You can use the panel 3-PPS/M or 3-BPS/M power supplies.

When using CRCXF CRC Transformer you must provide a circuit common path between all devices, using the -24 Vdc terminals.

If you use an additional power supply other than the CRCXF, that power supply must be listed for fire alarm applications, must have ground fault detection disabled, and must have a circuit ground (circuit common) that is isolated from earth ground.

Hardware configuration

The CRC has two jumpers that configure the power source and usage for the module. See the CRC installation sheet for details on the jumper settings.

No other configuration settings are made at the device itself. All other configuration is done via SDU or ACDB programming.

The SDU determines site-level configuration and parameters. The ACDB program controls end-user settings.

SDU programming

While the ACDB program defines the access control database, all other definition, configuration, and programming for the access control system happens in the SDU.

The SDU controls the general configuration of the 3-SAC modules, plus the configuration of all CRC devices on the SAC busses.

CRC modules can be configured to execute a specific, predefined command list when a specific access control event occurs. You write the command lists in the SDU, and assign them to CRC events when you configure the CRC module.

Partitions are fundamental groups used with access control systems. To use such access control features as two man rule, muster, or anti-passback, CRCs must belong to the same partition. All partitions are created and defined in the SDU, and each CRC can be assigned to a partition.

For the 3-MODCOM module, the SDU determines the dialer and modem parameters, defines the receivers and accounts, and assigns each account to the correct receiver. These settings control CMS reporting and ACDB download operation.

Finally, the SDU includes the RPM tool, described earlier in this topic.

ACDB operation

The ACDB program lets you create and revise your access control database. Parameters stored in the database identify cardholders, schedules, and holidays, and assign access privileges.

The SDU includes a tool called the Resource Profile Manager (RPM). The RPM lets you create a resource profile for each company using the system for access control purposes. During setup of the ACDB program, you import the resource profile created by the RPM. This defines the system devices for the ACDB program.

The ACDB runs on your computer. You can connect the computer to the access control system in two ways:

- From an RS-232 port on the computer to an RS-232 port on the CPU
- From the computer modem to a 3-MODCOM via telephone lines

The end result is that the ACDB database can be downloaded from your computer to the system. Each CRC stores that portion of the database pertinent to its operation.

Locally defined unlock and open timers

Using the ACDB program, you can control how much time a cardholder has to enter or exit after badging in or pressing a request-to-exit button (REX). The CRC controls both the unlock time and door open time. Both can be set in the ACDB program.

Unlock timers control the number of seconds that the door stays unlocked after a cardholder badges in. When the unlock timer expires, the door locks. The ACDB has four unlock timers:

- Standard unlock
- Handicap unlock

Access control applications

- Manual unlock
- Minimum unlock

The CRC relay can be used to control a door opener. Door open timers control the number of seconds that the relay remains active. The ACDB has two door open timers:

- Manual open time
- Relay open time

Access control applications

The remaining topics in this chapter discuss specific access control applications. Each topic gives you an overview of the application, showing the components required and their interconnection.

Each topic includes a block diagram and general description of the application. Other factors (as called out on the drawings) are discussed under separate headings in the topic.

Anti-passback

Description of the application

Anti-passback is a feature of the access control system that prevents successive use of one card to pass through any door in the same direction. Anti-passback prevents a card from being passed back to another person for the purpose of gaining unauthorized access.

The CRC supports three forms of anti-passback:

- Strict
- Logged
- Timed

Strict anti-passback is the most restrictive form of anti-passback. It requires all personnel to badge in and out, denying them access to an area when they fail to do so.

Logged anti-passback is less restrictive than strict anti-passback. It still requires personnel to badge in and out but does not deny access when anti-passback rules are violated. Rather, such access is logged as an access granted anti-passback event. With logged anti-passback, security staff can work to correct violations, but personnel are not locked out.

Timed anti-passback prevents reuse of a card for a specific period, but does not require personnel to badge out. A timed anti-passback system automatically badges a cardholder out of the controlled partition after a specified time period, allowing the card to be used again.

Note: Timed anti-passback cannot be used with a muster application, since the system automatically logs cardholders out of the partition, defeating muster accounting.

To implement anti-passback, a separate CRC is required at each doorway in the controlled partition. Each doorway requires an outside card reader. Strict and logged anti-passback applications also require an inside reader at every doorway. Timed anti-passback does not require the use of an inside card reader.

A typical anti-passback application is shown in Figure 3-2, below.

The figure shows a building with a perimeter fence. It would be easy for an employee to pass his access card to an unauthorized individual through the fence, thereby allowing access. Configuring the access control system for anti-passback operation can help prevent this from happening.

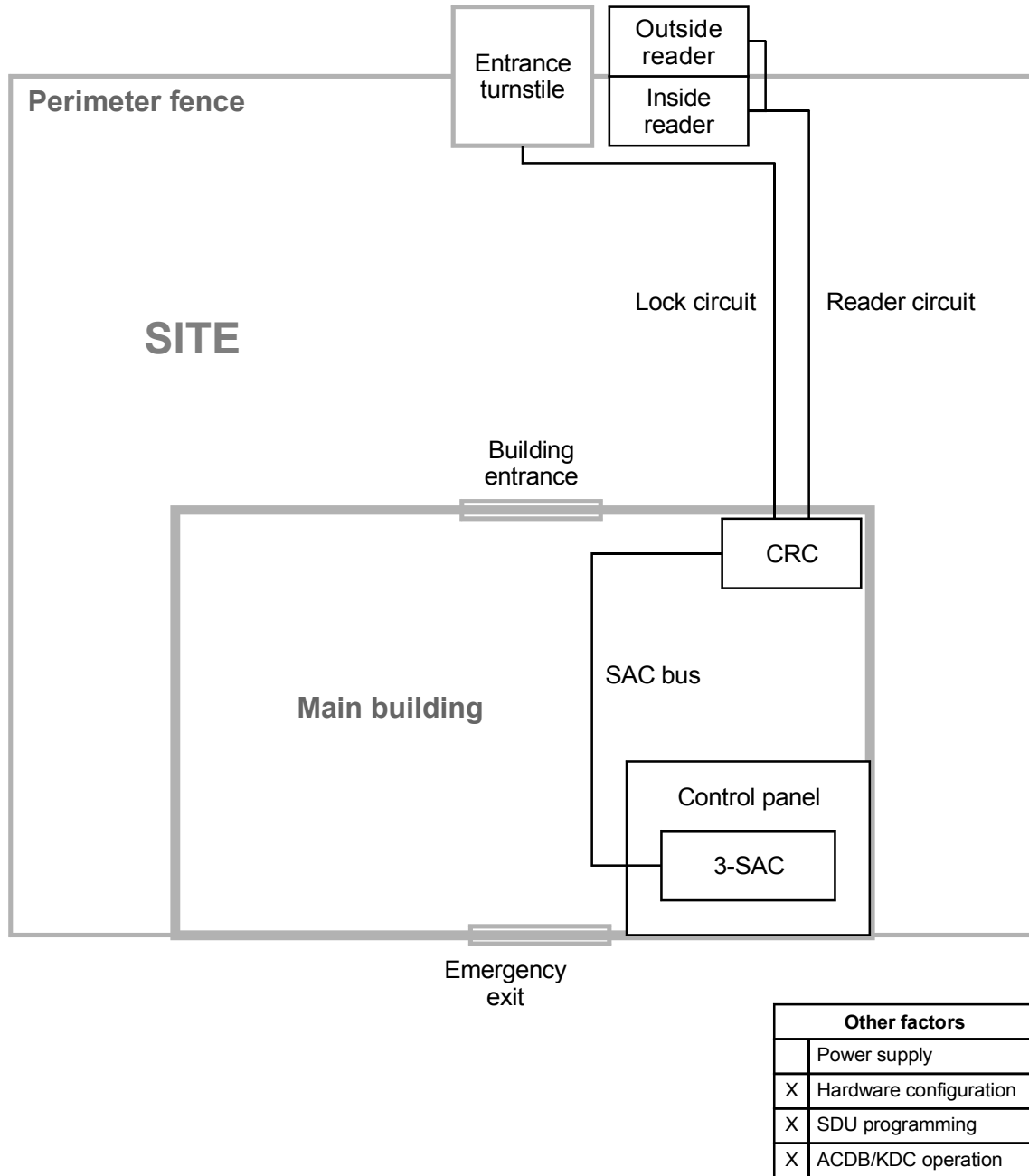

Figure 3-2: Anti-passback

Hardware configuration

The control panel must contain a 3-SAC Security Access Control module. The 3-SAC module supports the SAC bus. Power for the CRC can be taken from the 3-PPS/M and routed with the data lines in a cable composed of two twisted-pair wires (the SAC bus).

SDU programming

If the CRC is to be used for anti-passback this must be configured using the SDU. The CRC configuration dialogs let you select the type of anti-passback you want to use:

- None
- Logged
- Timed
- Strict

You can also assign a predefined command list to various access granted or access denied events, including the anti-passback events:

- Access granted anti-passback
- Access denied anti-passback

The CPU runs the command list you specify when either of these events occurs.

ACDB programming

With timed anti-passback, the cardholder is automatically marked out after a specified period of time. This period is defined by the ACDB. The period can be set from 0 through 255 minutes (4 hours and 15 minutes).

Central monitoring station

Description of the application

An access control system can transmit different kinds of event information to a central monitoring station (CMS). The basics for such a system are shown in Figure 3-3.

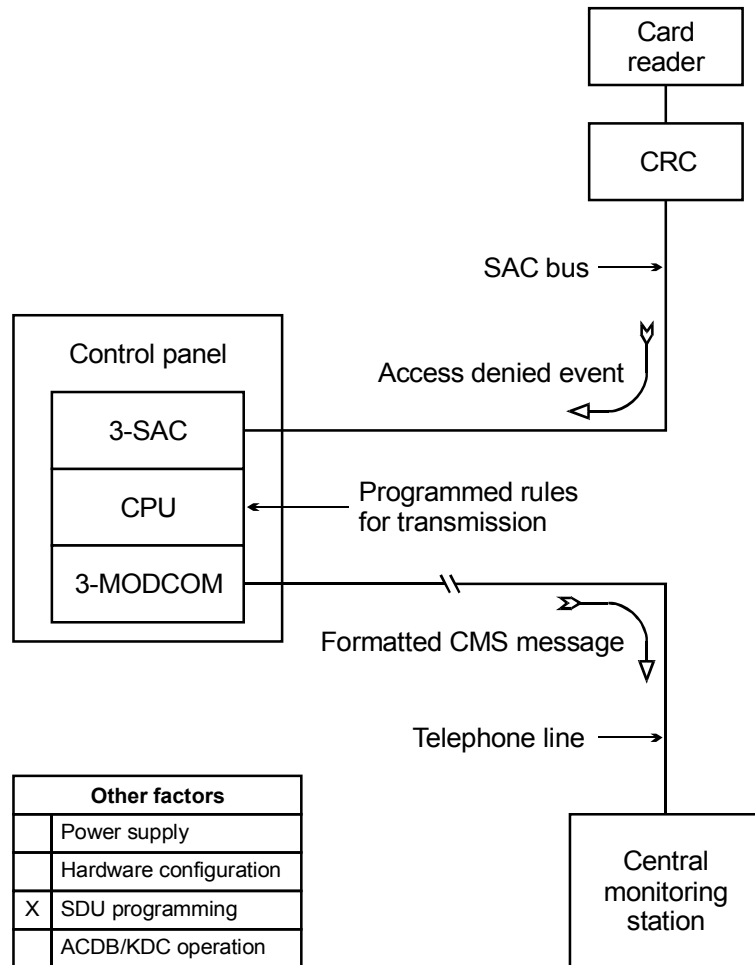

Figure 3-3: Access control reporting to a central monitoring station

When a reportable access event occurs, the event message travels from the CRC to the 3-SAC. The 3-SAC passes the message to the CPU which executes a predefined command list. The command list specifies the details of the message that is sent to the 3-MODCOM for transmission to the CMS.

SDU programming

Reporting access control events to a CMS depends entirely on programming and the creation of command lists. In essence, you must assign a command list to each CRC event you want to report. The command list contains the details of the message to be transmitted.

The following CRC events can be assigned command events:

- Access granted
- Access granted irregular
- Access granted anti-passback
- Access granted muster
- Access denied unknown
- Access denied reader disabled
- Access denied access level not active
- Access denied outside schedule 1
- Access denied outside schedule 2
- Access denied partition armed
- Access denied PIN not entered
- Access denied PIN not valid
- Access denied two-person timeout
- Access denied anti-passback
- Access denied escort

Common door access

Description of the application

A site that makes use of a common door is shown in Figure 3-4. Here, the door is the main entrance of an office building, and leads into a common lobby area. Within the building, two companies rent offices, each with controlled access doors.

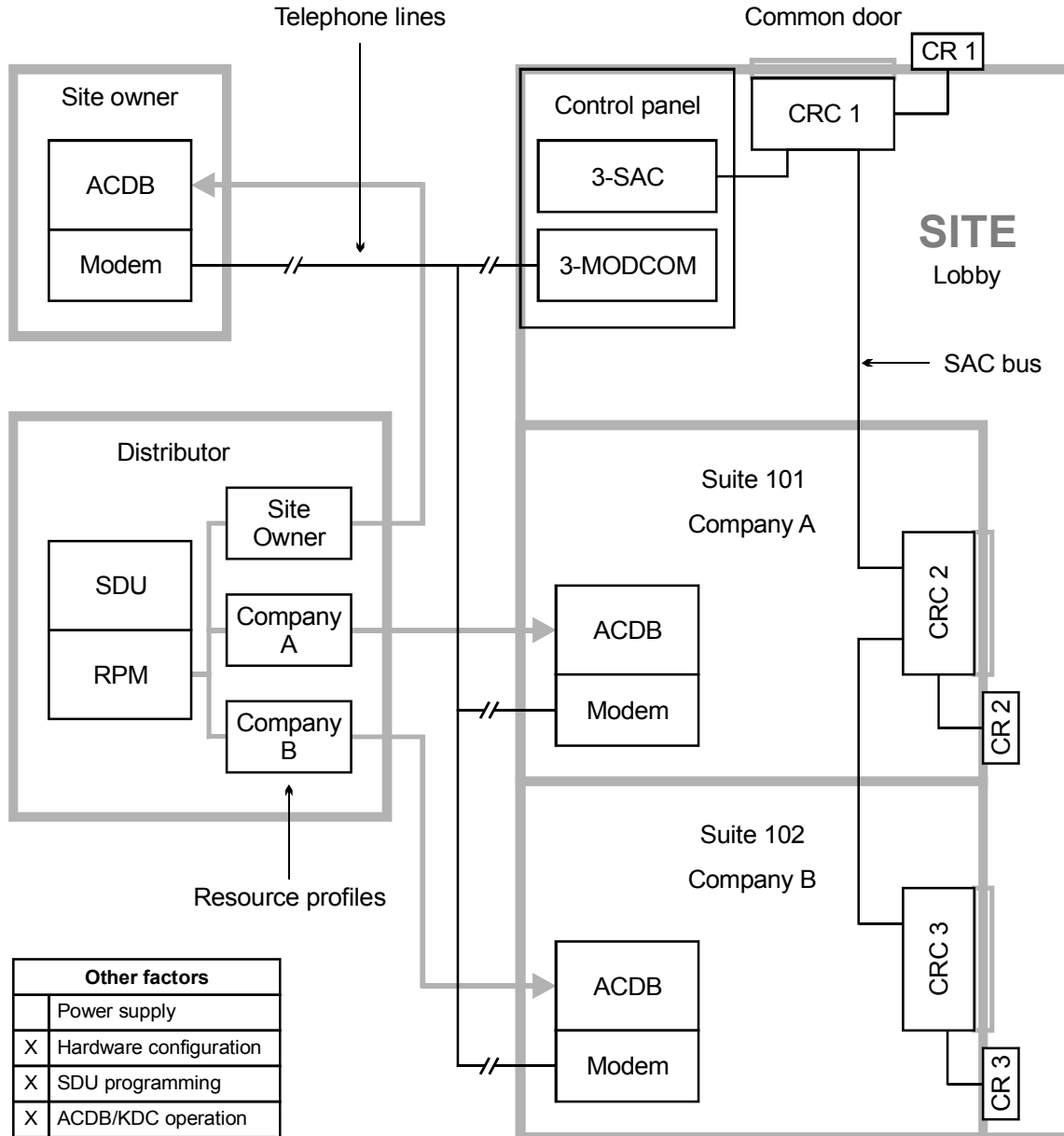

Figure 3-4: Common door in a lobby area

Hardware configuration

The site has an EST3 control panel that includes a 3-SAC and a 3-MODCOM module. The 3-SAC supports the SAC bus. The 3-MODCOM module supports modem communication with the control panel over telephone lines.

SDU programming

As the distributor, you use the SDU to program the control panel for this application. Part of the programming job is to use the Resource Profile Manager (RPM) to create resource profiles for the site owner and for each tenant company.

Resource profiles are imported into the Access Control Database (ACDB) program. They determine which devices the user can see and program. Resource profiles also establish transmission routes that permit modem communication with the EST3 panel.

When a device is shared, the RPM lets you specify how much of the device is allocated to each company. You can allocate resources either by percentages or by actual numbers.

It's a good idea to hold some allocation in reserve, giving each company only what it needs. It is much easier to allocate additional resources as needed than to reclaim resources that are already allocated.

In our example, the resource profile for company A would contain CRC 1 (the lobby door) and CRC 2 (the suite 101 door). For Company A, you might choose to allocate 80% of CRC 2, and 20% of CRC 1.

Similarly, the resource profile for company B would allocate 80% of CRC 3 and another 20% of CRC 1.

The site owner will need access to the CRC2 and CRC3 doors for cleaning or inspection purposes. The site owner resource profile could allocate 20% of CRC 1, 10 % of CRC 2, and 10% of CRC 3.

This leaves 40% of CRC 1 unallocated, and 10% of CRC 2 and CRC 3 unallocated. The unallocated resources are reserved for future expansion or changes.

ACDB operation

The site owner, the owner of company A, and the owner of company B, can all use telephone lines to communicate with the control panel via the 3-MODCOM module. They can download additions and changes to the CRCs, and upload usage data for various ACDB reports.

Delayed egress

Description of the application

Delayed egress doors help to control shoplifting at retail sites. A delayed egress door has card readers and a request to exit (REX) switch. Employees can badge in and out as they would at any other door. In an emergency, customers must press the REX switch to unlock the door.

When the REX switch is activated, the CRC sounds the CRCSND horn and sends a security alarm event to the panel. It does not unlock the door immediately, thus allowing site staff time to investigate.

The CRC waits for a specific interval of time before unlocking the door. The typical delay time is 15 seconds; however, you may be able to use a delay of up to 30 seconds with the approval of the AHJ. The horn continues to sound for a specific period of time, or until the CRC is reset.

After the delay time passes, the CRC unlocks the door, and latches it in the unlocked state. The CRC must be reset in order to relock the door and silence the horn. To reset the CRC, site staff must use a valid badge at the card reader.

The CRC also activates the CRCSND horn if the door is opened without badging. For example, if the door is forced open from the outside, the CRCSND activates, even though the REX switch has not been pressed.

Many codes require that delayed egress doors unlock during a fire alarm, or when the panel is in trouble. This requirement allows occupants to evacuate the site immediately when a fire is detected, or when the panel loses its ability to detect a fire or sound the alarm.

Figure 3-5 shows a delayed egress door with inside and outside card readers and a request to exit switch. The CRC uses a door contact switch to determine the position of the door, and a maglock to lock the door. The door contact switch and REX switch are connected to the input loops of the CRC.

Note: Refer to NFPA 101 and the local AHJ to determine the requirements for delayed egress applications.

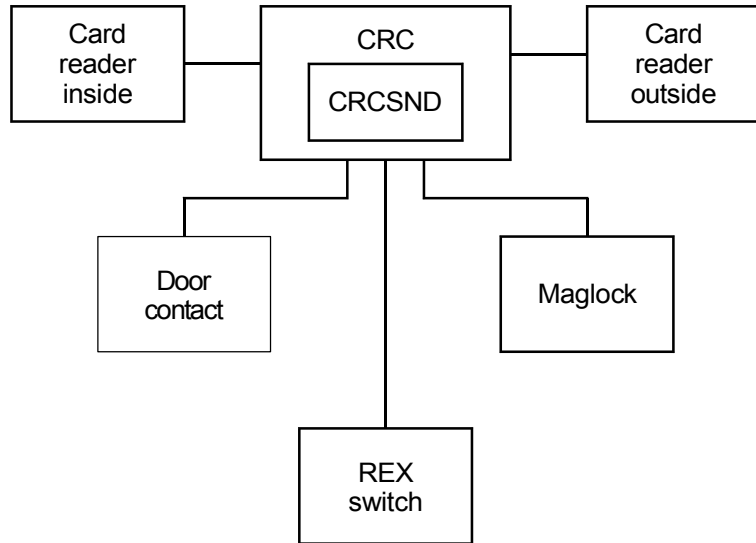

Other factors	
	Power supply
X	Hardware configuration
X	SDU programming
X	ACDB/KDC operation

Figure 3-5: Delayed egress doorway

Hardware configuration

A maglock is most commonly used for delayed egress applications, but you can use any locking device that has no manual override. For example, a strike with no knob could be used.

The door contact is used to detect unauthorized opening of the door. The CRC activates the CRCSND and reports a security alarm event when the door is opened without badging or use of the REX.

The door contact signal is also required to relock the door when the CRC is reset. The lock cannot be reset until the door is closed.

SDU programming

Most codes require you to program rules that unlock the door when the panel goes into alarm or when the panel goes into trouble.

When configuring the CRC, set the Delayed Egress Time field to the value (in seconds) you want to use. Define the input loops as follows.

For the door contact input loop:

- Device Type = Security P Monitor
- Input Circuit Partition = as determined by project
- Max Delta Count = as determined by project
- Delays = None
- Application = Emergency Exit Door Contact
- Personality = Basic

For the request to exit switch:

- Device Type = Monitor
- Input Circuit Partition = None
- Max Delta Count = not applicable
- Delays = None
- Application = Request to Exit with Delayed Egress
- Personality = N.O. with Trouble

ACDB operation

When an employee badges in or out at the door, the CRC bypasses the door contact for a specified period of time. This is called the Bypass Time, and is specified in the ACDB.

The duration of the CRCSND horn is also specified in the ACDB, as the Emergency Exit Sounder Time. This can be set to any value between 0 and 255 seconds.

Setting the value to 0 seconds effectively inhibits the CRCSND. Setting the value to 255 seconds programs the CRC to operate the CRCSND until the CRC is manually reset by badging at the CRC card reader.

Elevator control

Description of the application

An access control system can determine which floors are available to a given cardholder. This application is shown in Figure 3-6.

A CRC and independent power source are installed in the elevator cab. When a cardholder presents his card it is processed by the CRC. If valid, the CRC sends an access granted event and a command list request to the CPU via the 3-SAC.

The command list operates the Signature relay modules attached to the Signature Controller module. The relays are connected to the elevator controller, and turn on or off access to the correct floors, according to the cardholder's access level privileges.

The command list includes timing, so the cardholder has a limited window of opportunity during which he can press the desired floor button. After the time has lapsed, he must present his card again.

Note: This application must be used only for floor access, and *not* for elevator control.

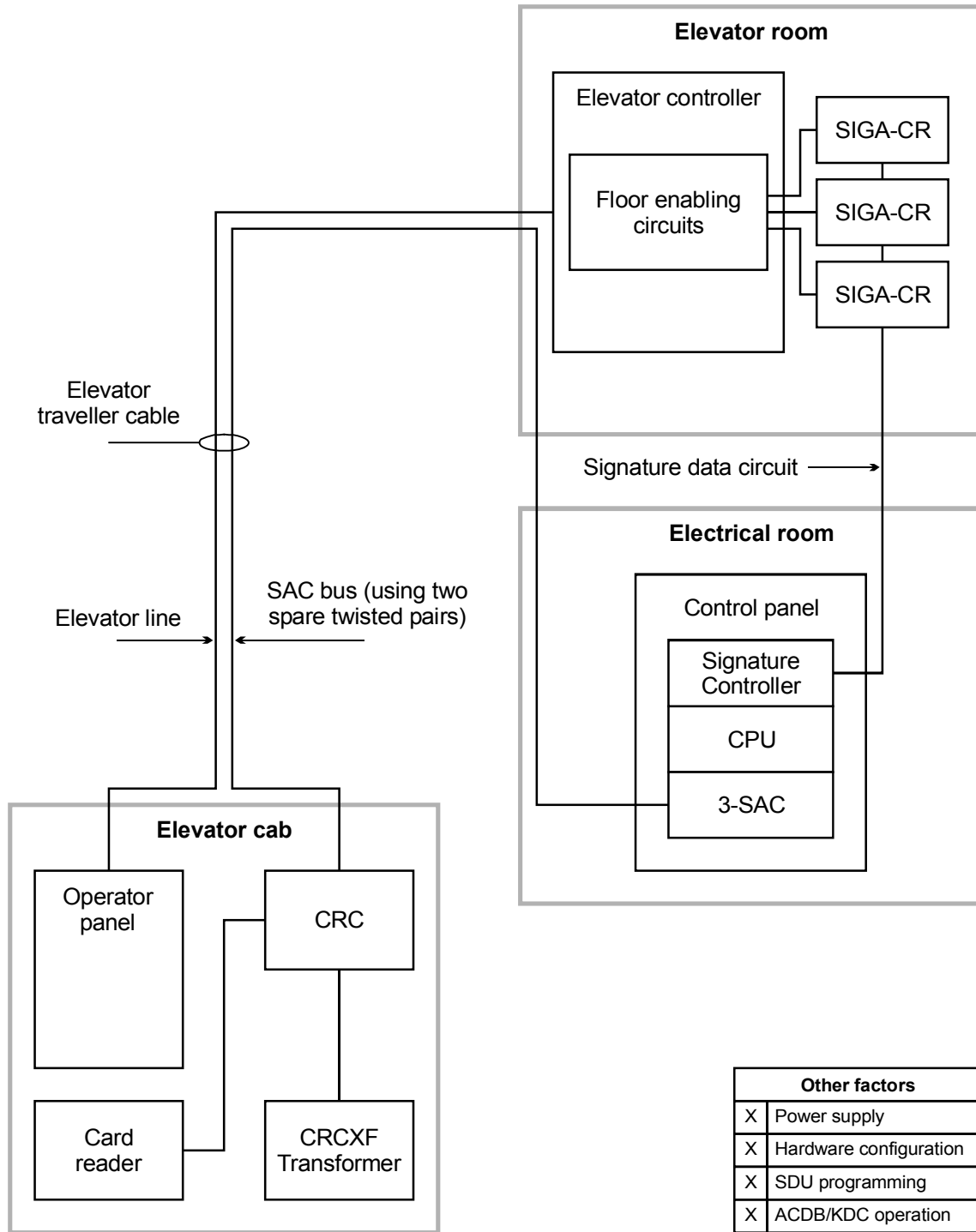

Figure 3-6: Access control and elevators

Power supply

The figure shows an independent power source for the CRC. This is suggested due to the length of cable from the cab to the electrical room.

Two pairs of wires are used to connect the CRC to the control panel. The SAC bus requires one pair for data communication. One wire of the second pair is required to maintain a common ground between the control panel and the CRC. For details, refer to the topic “Power from an AC source,” later in this chapter.

If you use an additional power supply other than the CRCXF, that power supply must be listed for fire alarm applications, must have ground fault detection disabled, and must have a circuit ground (circuit common) that is isolated from earth ground.

Hardware configuration

In this application, none of the CRC input circuits or relay contacts are used. The CRC simply reads the card and passes the command list request to the 3-SAC and CPU for processing.

Since the CRC lock and input circuits are not used, you must provide dummy loads to maintain correct supervision currents. See the installation sheet for the correct load values.

SDU programming

The SDU programmer must create a command list for each combination of floors desired.

ACDB operation

The site security officer determines which floors should be accessible for an access level, and assigns the correct command list to the access granted event for that level. The site security officer also determines which cardholders belong to each access level.

Emergency exit door

Description of the application

An *emergency exit door* is a door that is unlocked from the inside either by badging out or by opening the door.

If the door is opened without badging out, it causes an immediate alarm. Badging out bypasses the door for a specific period of time, so no alarm event occurs.

A typical CRC application for emergency exit door is shown in Figure 3-7 below.

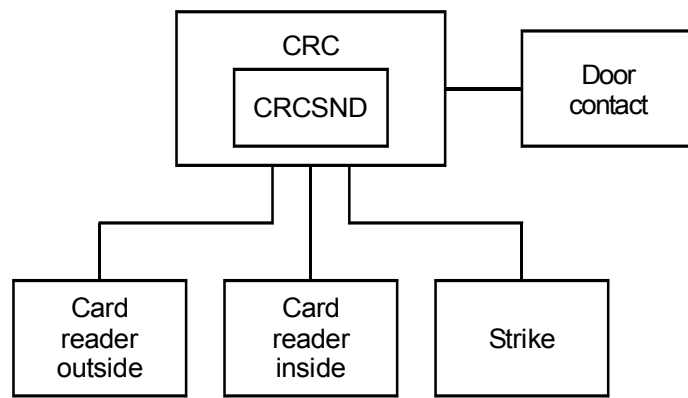

Other factors	
	Power supply
X	Hardware configuration
X	SDU programming
X	ACDB/KDC operation

Figure 3-7: Emergency exit door

Note: Refer to NFPA 101 and the local AHJ to determine the requirements for emergency exit applications.

Hardware configuration

A CRC used for an emergency exit door requires the following additional hardware:

- CRCSND CRC Sounder
- Door contact

The CRCSND is installed inside the CRC. The sounder provides a local sound alarm. Opening the door without badging out activates the CRCSND.

The door contact is connected to the CRC via the input circuit.

SDU programming

In the SDU, you'll need to define the input circuit for the door contact as follows:

- Device type: Security P Monitor
- Delays: None
- Application: Door Contact
- Personality: Basic

ACDB operation

Two time periods are defined in the ACDB: Emergency Exit Sounder Time, and Bypass Time.

Emergency Exit Sounder Time is the number of seconds (0 through 255) the CRC Sounder sounds when an emergency exit door is opened without badging out.

When set to zero, the sounder is disabled. When set to 255, the sounder sounds until manually reset. The sounder is reset when a cardholder badges in at the door.

In all cases badging in on the affected CRC can silence the sounder.

Bypass Time is the number of seconds (0 through 255) that the door is bypassed after a cardholder badges out.

Handicap access door

Description of application

A *handicap access door* is a door that helps a handicapped person enter and exit a door by allowing extra access time and providing an automatic door opener. See Figure 3-8, below.

The door can function for both normal access and handicap access. A person without handicap privileges would operate the door just as any other door.

When a person with handicap privileges badges in, the CRC recognizes that the person has handicap privileges and provides two extra benefits. The first is giving the handicap person extra time to enter or exit the doorway before relocking the door. The second is an automatic door opener.

A second card reader can be installed in parallel to the entry or exit card reader to make it easier for a handicapped person to reach. The second card reader should be placed at a lower level and farther away from the door. The distance from the door should allow the automatic door to open fully without a person needing to move backwards.

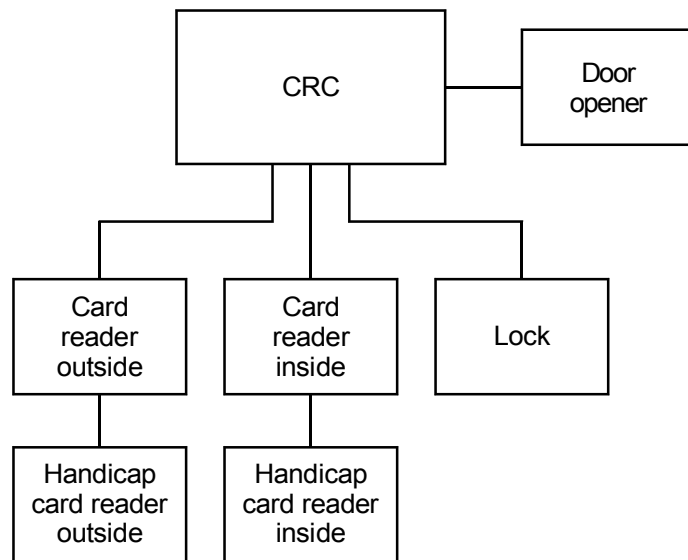

Other factors	
	Power supply
X	Hardware configuration
X	SDU programming
X	ACDB/KDC operation

Figure 3-8: Handicap access door

Note: Refer to the appropriate ADA codes and the local AHJ to determine the requirements for handicap access door applications.

Hardware configuration

A CRC used for a handicap access door may require the following additional hardware:

- Automatic door opener
- Additional card readers

The automatic door opener is installed directly to the access door. The CRC controls the opening of the door with its internal relay.

Caution: The CRC relay is for low-voltage only. Do not exceed the relay limits stated on the installation sheet.

The additional card readers are wired to the standard card readers in parallel.

SDU programming

In the SDU, you'll need to define the CRC relay device type as Access Door Control. This will activate the door opener for the time specified by the ACDB.

ACDB operation

The relay open time needs to be defined in the ACDB. This is the number of seconds (0 through 255) that the CRC will activate the relay that automatically opens the door. The default is 30 seconds.

The handicap unlock time also needs to be defined in the ACDB. This is the number of seconds (0 through 255) that the lock will stay unlocked. The default is 20 seconds. The door will relock when the unlock time has expired and the door has closed.

Both of these times can be set to allow a longer access time for a handicapped person.

Maglock peripherals

Description of the application

Maglocks require *maglock peripherals* due to NFPA codes. In general, these devices are intended to ensure that an egress door secured with a maglock can always be opened in an emergency.

Figure 3-9 shows the CRC using a maglock and required peripherals.

Maglock application requires a passive infrared motion detector (PIR) to be mounted above the door. Also required is a request to exit (REX) switch to be mounted within five feet of the door and 40 to 48 inches above the ground. The PIR is connected on the input circuit of the CRC. The REX is connected directly to the maglock so that when activated it unlocks the door independently of the CRC.

The CRC is designed so that on detection of a fault on the input circuit of the PIR, the door will unlock. The PIR detects an approaching body and unlocks the door. Similarly, the REX switch unlocks the door when it is pressed. The REX switch must unlock the door for a minimum of 30 seconds.

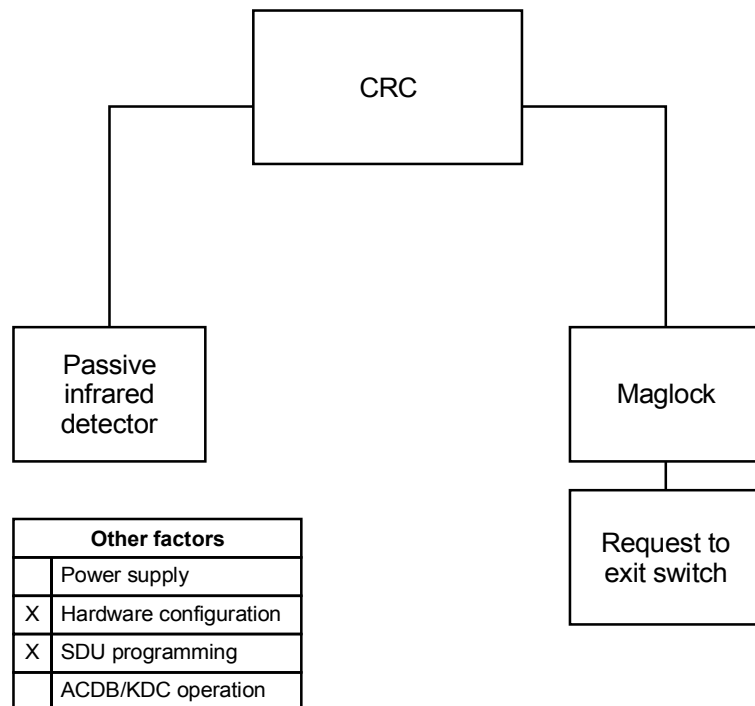

Figure 3-9: Maglock and peripherals

Hardware configuration

The maglock peripherals consist of the following:

- Passive infrared motion detector (PIR)
- Request to exit (REX) switch

The PIR is connected via the CRC input circuit. The REX is connected directly to the maglock instead of the CRC input circuit to meet NFPA requirements.

SDU programming

When programming the system for this application you'll need to configure the CRC, defining the device type. You'll also need to define the input circuits. For this application define the input circuit for the PIR as follows:

- Device type = Security interior
- Application = Request to exit motion detector.

Multiple card readers

Description of the application

Several access control applications require the use of multiple card readers. For example:

- Visitor and escort readers
- High and low position readers

The CRC lets you use multiple card readers of the same technology or of mixed technologies. It can support up to four card readers, provided that the total current draw of the readers does not exceed the limits specified on the CRC installation sheet.

A visitor and escort application using multiple card readers is shown in Figure 3-10, below. In this application, both the escort and visitor must badge in to gain access.

The escort has a permanent, plastic card, and uses the proximity card reader. The visitor is issued an inexpensive paper bar code card, and uses the bar code reader.

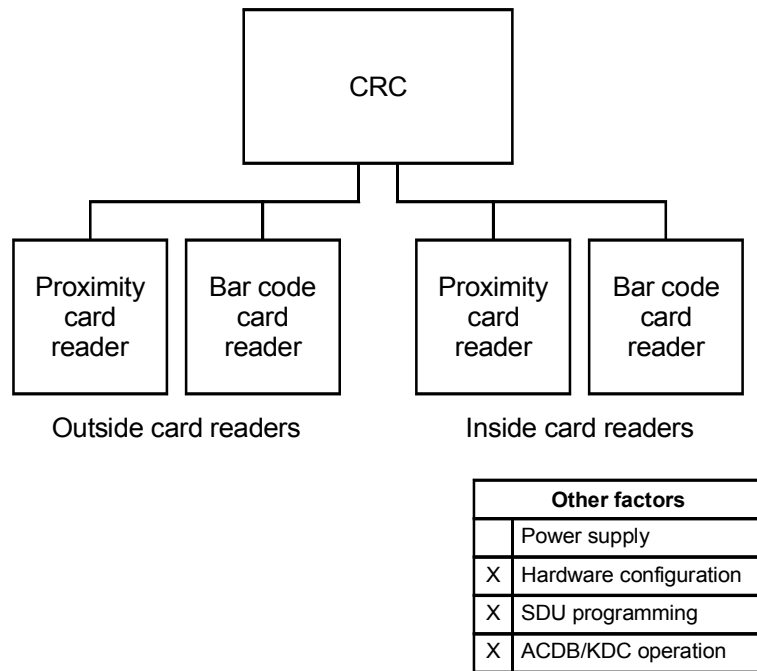

Figure 3-10: Multiple card readers

Card reader

This application works best with card readers that support dual LED control. The CRC uses the second LED (or LED state) to signal the visitor that the escort must badge in before access is granted.

Hardware configuration

The proximity card reader and barcode card reader are connected to the same terminals of the CRC.

SDU programming

When an escorted visitor tries to enter a controlled area without an employee, the CRC generates an access denied escort event. You can select a predefined command list that the CPU executes in response to this event.

ACDB operation

Like employees, visitors must be assigned an access level using the ACDB. The site security officer can elect to assign the same access level to all visitor cards, or assign different access levels to ranges of visitor cards.

Muster

Description of the application

The *muster* application can be used to determine who has exited the building in the event of an evacuation.

During normal operations, staff badge in and out using the inside and outside readers. Note that muster reporting will only work if all employees badge in and out.

During an evacuation, everyone exits the building immediately and goes to one of the predetermined muster stations. At the muster station personnel badge in using a reader that is attached to a CRC designated as a muster station.

After everyone has badged in at the muster station security staff use the ACDB program to create a muster report. The report lists staff who badged into the building but did not badge out at a muster station.

Figure 3-11 shows a typical muster application. CRCs 2, 3, 5, and 6 are normal access control CRCs. CRCs 1 and 4 are muster station CRCs.

The ACDB computer must be located in a safe area so security staff can create the muster report after the evacuation. This computer can connect to the access control system either via telephone lines and a 3-MODCOM, or by direct connection to the EST3 control panel.

Note: Links between the ACDB computer and the control panel should be tested regularly to ensure correct operation.

Staff must be made aware of the importance of badging in and out at all times. Failure to do so can result in a false muster report, indicating that someone is still in the building. This in turn can result in rescue personnel risking danger to search for someone who is not actually in the building.

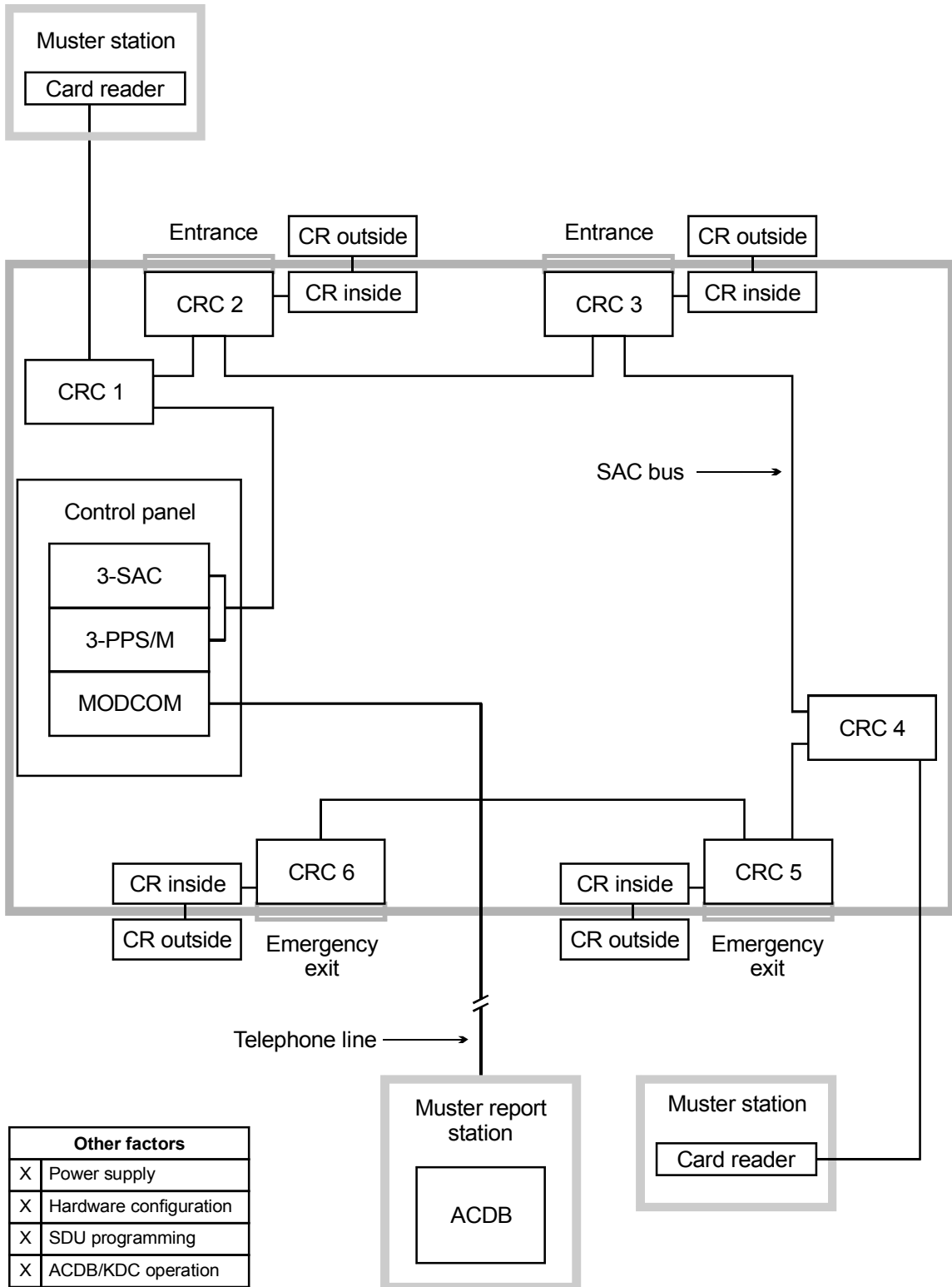

Figure 3-11: Muster application

Hardware configuration

The control panel must contain the following rail modules:

- 3-SAC Security Access Control module
 - 3-PPS/M Primary Power Supply module
 - 3-MODCOM Modem Communication module
- or—
- 3-RS232 Card option installed in the CPU

The 3-SAC module supports the SAC bus. Power for the CRC is normally taken from the 3-PPS/M and is routed with the data lines in a cable composed of two twisted-pair wires.

The 3-MODCOM module supports modem communication between the control panel and the ACDB program via telephone lines. Alternately, the 3-RS232 Card supports RS-232 communications on a cable connected directly to the CPU.

All CRCs controlled by a muster station must be on the same 3-SAC card as the muster station. Badging out at a muster station badges the person out of all partitions for that 3-SAC card. Therefore, a single muster station can serve multiple partitions, provided that they are on the same 3-SAC card.

The system must have at least one muster CRC per 3-SAC module. The system cannot exchange muster information between 3-SAC modules, so each must be handled separately for muster purposes.

A CRC used for a muster station requires the specified dummy load on the lock terminals to maintain supervision. (Refer to the CRC installation sheet for correct resistor values.)

The card reader used for the muster station must be wired as an outside reader.

SDU programming

Each CRC used in a muster application requires specific configuration settings. These are made in the SDU program, on the CRC Configuration tab.

If the CRC is used in a partition that has muster control, check the Muster Support box.

For the CRC designated as the muster station, check the Muster Station box, but leave the Muster Support box clear.

In the SDU, you can also assign a predefined command list to the Access Granted Muster event.

Power for continuous locks

Description of the application

By *continuous locks*, we mean locks that operate, on average, more than 30 seconds in every minute. Normally, power for the lock is taken from the CRC battery. However, for continuous locks there is not enough recharge time for the CRC battery to keep up with the drain. Consequently, the CRC must be configured so that an external power supply operates the lock.

The CRC can be powered by the 3-PPS/M, by a CRCXF (CRC Transformer), or by a remote 24 Vdc power supply. Any of these supplies is suitable for powering continuous locks. (See the topics “Power from an AC source” and “Power from a remote source” for more information about these options.)

A typical application using continuous locks is shown in Figure 3-12, below.

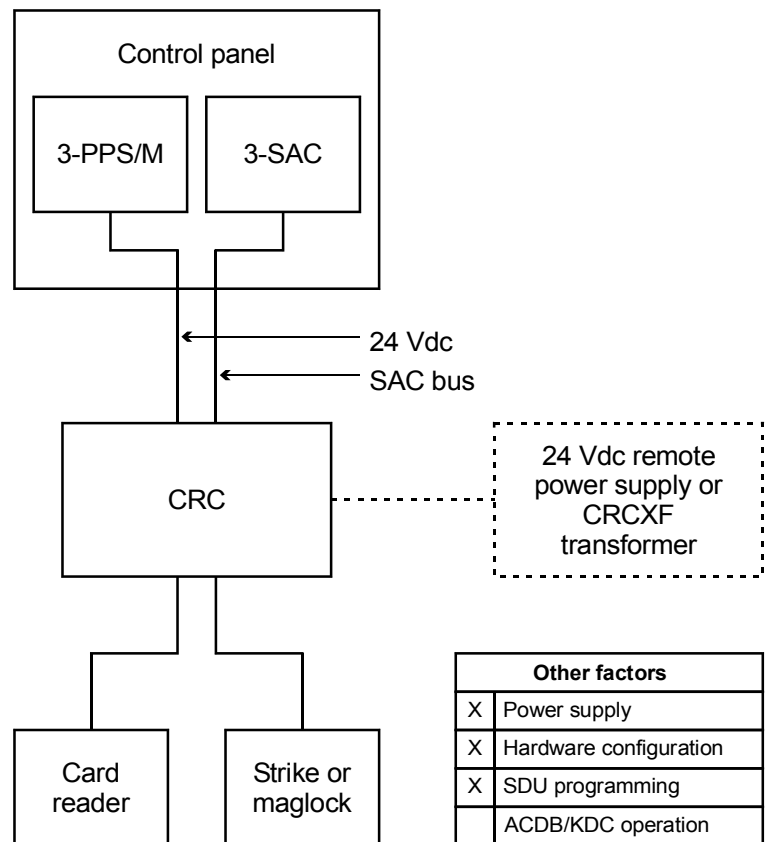

Figure 3-12: CRC controlling a continuous lock

The figure shows the power coming from the 3-PPS/M in the control panel. This power supply could be used to operate the

lock, but use of a CRCXF or remote 24 Vdc supply is recommended to minimize the load on the panel power supply.

During open schedules, or when an authorized card is read at a card reader, the CRC provides power from the 3-PPS/M to the door strike to unlock the door. For maglocks, the CRC provides power from the 3-PPS/M (or CRCXF or 24 Vdc power supply) to activate the lock during closed schedules, or between authorized card accesses.

Power supply

Use power and load calculations to determine the need for remote power supplies or transformers. Refer to *the CRC Technical Reference Manual* for calculation guidelines.

Jumper settings determine the power source and usage for the CRC. Refer to the installation sheet for correct jumper settings. Configure the input power as DC when using power from the control panel or a remote supply. Configure input power as AC when using a transformer.

For this application, configure the output power as continuous.

Hardware configuration

The control panel must contain the following rail modules:

- 3-SAC Security Access Control module
- 3-PPS/M Primary Power Supply module

The 3-SAC module supports the SAC bus. Power for the CRC is taken from the 3-PPS/M and is routed with the data lines in a cable composed of two twisted-pair wires.

SDU programming

When configuring the system for this application, you'll need to configure the CRC and define the appropriate lock type in the SDU. For this application the Lock Type can be either Strike or Maglock as required to match the lock actually used.

Power for intermittent locks

Description of the application

By *intermittent locks*, we mean locks that operate, on average, less than 30 seconds in every minute. In these applications, the CRC battery can provide the power needed to operate the lock.

The CRC can be powered by the 3-PPS/M. It uses this power source to charge an internal 1.2 Ah sealed lead acid battery. The battery then provides the power needed to operate the door lock.

Because the battery powers the door strike, this configuration cannot be used for maglocks or strikes that are active more than 30 seconds in a minute. In these conditions the battery would not have enough time to charge and keep up with the drain. For heavy or continuous duty applications, refer to the topic *Power for continuous locks* presented in this chapter.

A typical application using CRC battery power is shown in Figure 3-13, below.

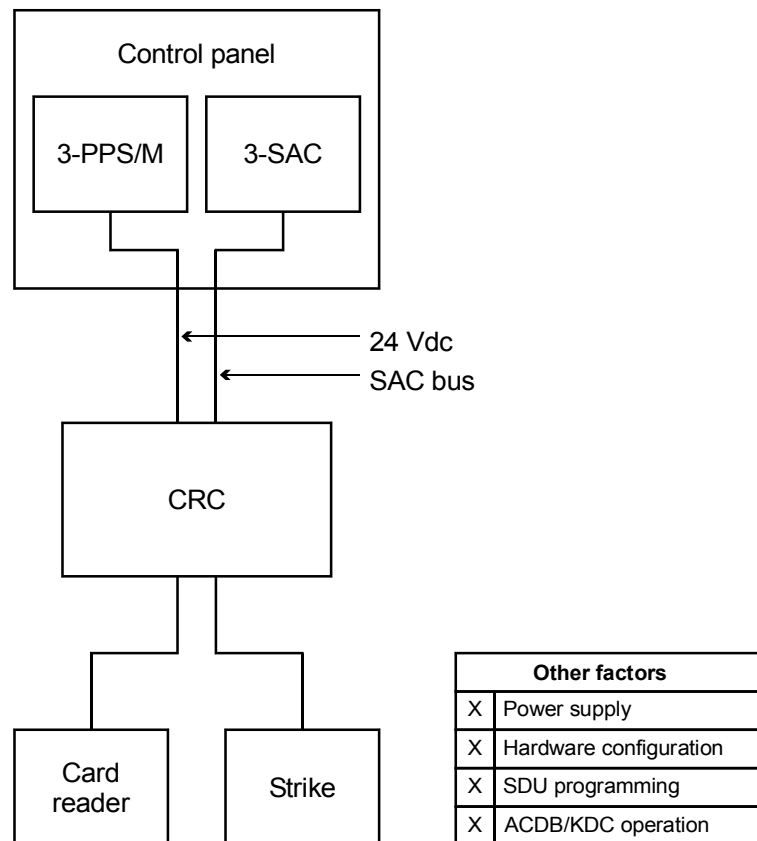

Figure 3-13: CRC controlling an intermittent strike

The figure shows the charging power coming from the 3-PPS/M in the control panel. The access control system requires a 24 Vdc power supply to power the CRC and to charge its battery. The 3-SAC connects to the CRC through the SAC bus.

When an authorized card is read at a card reader, the CRC provides power from its internal battery to the door strike and unlocks the door.

Power supply

Jumper settings determine the power source and usage for the CRC. Refer to the installation sheet for correct jumper settings. Configure the input power as DC. Configure the output power as intermittent.

Hardware configuration

The control panel must contain the following rail modules:

- 3-SAC Security Access Control module
- 3-PPS/M Primary Power Supply module

The 3-SAC module supports the SAC bus. Power for the CRC is taken from the 3-PPS/M and is routed with the data lines in a cable composed of two twisted-pair wires.

SDU programming

When configuring the system for this application, you'll need to configure the CRC and define the appropriate lock type in the SDU. For this application set the Lock Type to Strike.

ACDB operation

Note that a CRC configured and programmed for intermittent lock use cannot support an open schedule (a period when the lock is kept open). Such a schedule would quickly drain the CRC battery and the lock would close.

You should document the CRC configuration and include this in your project plans. Make a copy of this documentation available to the site security staff who will use the ADCB to create and assign schedules.

Power from an AC source

Description of the application

By *AC power*, we mean that the CRC provides the power to operate the electric door strike or maglock by using a 16.5 Vac transformer (model CRCXF). This supply can provide continuous power to the door strike or maglock, and also power the CRC.

Using an AC source:

- Limits power drawn from the control panel
- Supports continuous duty locks
- Supports schedules with unlock periods

Note: Be sure to check the installation sheet for the *CRC and CRCXM—Card Reader Controller Installation Sheet* (P/N 387625) for a list of applications that prohibit the use of the CRCXF.

A typical CRC using AC power is shown in Figure 3-14.

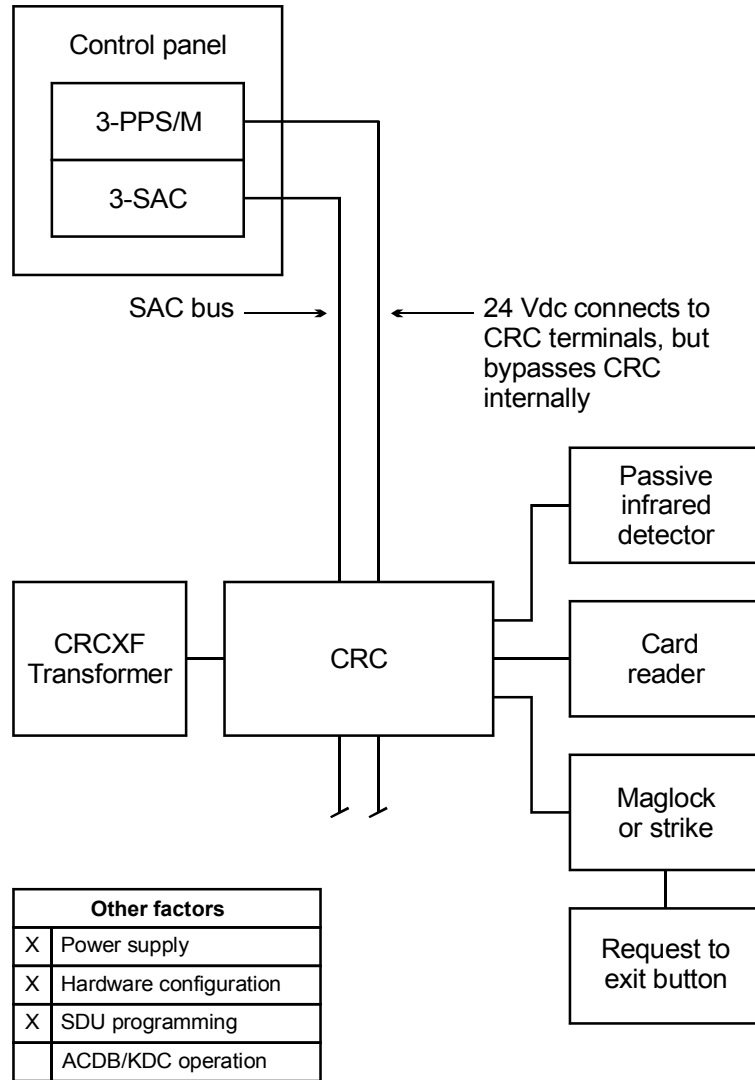

Figure 3-14: CRC using AC power

The figure above shows the CRC power coming from the 16.5 Vac transformer. The 3-PPS/M power supply coming from the control panel simply passes through the CRC. The 3-SAC connects to the CRC through the SAC bus.

This wiring is shown in Figure 3-15.

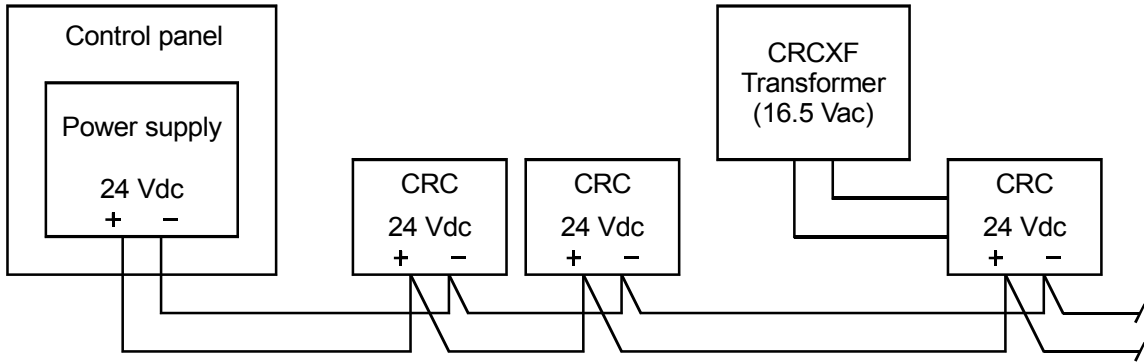

Figure 3-15: Wiring details for transformer supply

Power supply

Jumper settings determine the power source and usage for the CRC. Configure the input power as AC. Configure the output power as continuous.

If you use an additional power supply other than the CRCXF, that power supply must be listed for fire alarm applications, must have ground fault detection disabled, and must have a circuit ground (circuit common) that is isolated from earth ground.

Hardware configuration

The control panel must contain the following rail modules:

- 3-SAC Security Access Control module
- 3-PPS/M Primary Power Supply module

The 3-SAC module supports the SAC bus. Power for the CRC is normally taken from the 3-PPS/M and is routed with the data lines in a cable composed of two twisted-pair wires. In this case the power from the 3-PPS/M is connected to the CRC terminals, but internally bypassed.

The 16.5 Vac transformer should be plugged into a continuously energized AC socket, not one controlled by a switch.

SDU programming

When programming the system for this application, you'll need to configure the CRC and define the appropriate lock type in the SDU. This can be either a strike or maglock.

Power from a remote source

Description of the application

By *remote power*, we mean that the CRC provides the power to operate the electronic door strike or maglock by using a remote DC power supply. This additional power can provide continuous power to the door strike or maglock.

A typical CRC using remote power is shown in Figure 3-16. The additional power is needed because the CRC battery can not keep up with the power needs of maglocks or strikes with an active duty cycle greater than 30 seconds in a minute. In these conditions the battery does not have enough time to charge and keep up with the drain.

The figure shows power coming from the additional remote power supply to power the CRC and maglock. The supply is supervised by the Signature data circuit derived from the 3-SSDC(1) module. The 3-SAC connects to the CRC through the SAC bus.

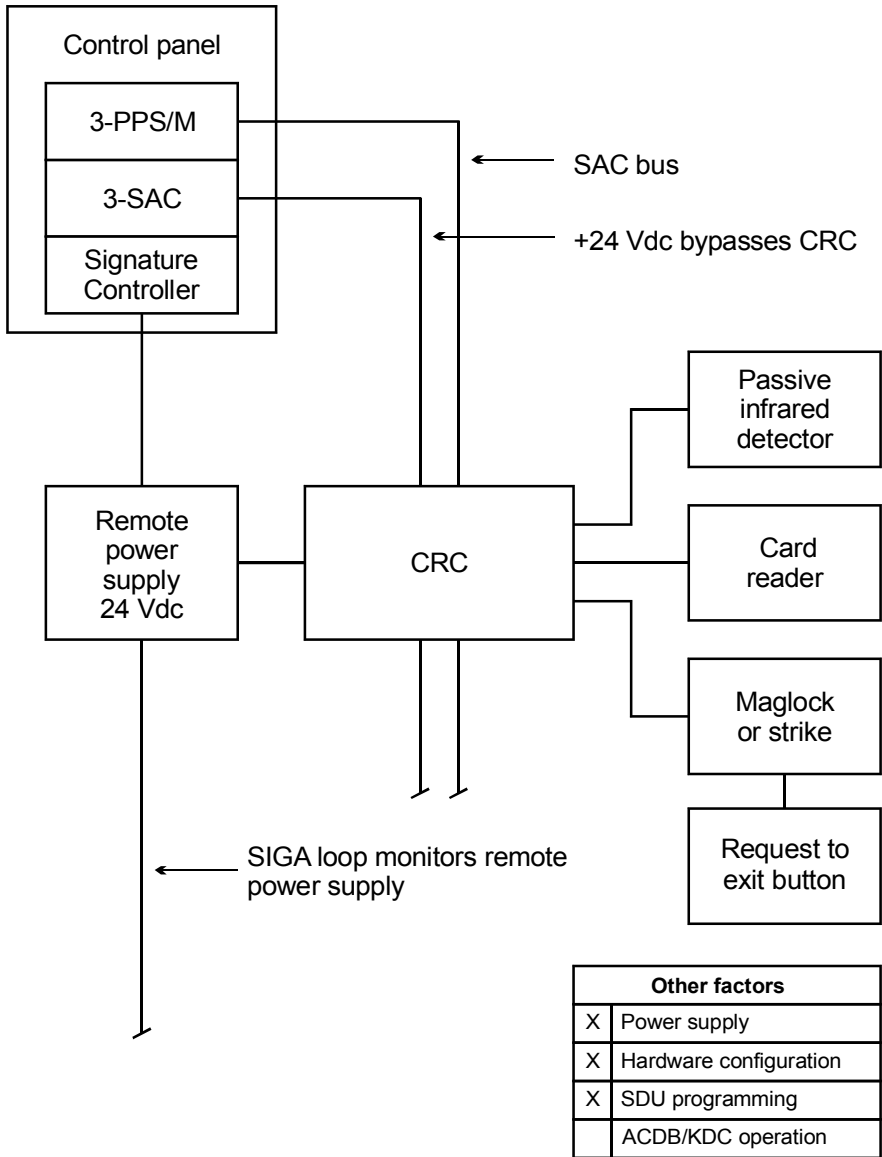

Figure 3-16: CRC using remote power

The negative side of the 3-PPS/M power supply coming from the control panel connects to the CRC (and to all other CRCs). The positive side is broken and the remote power supply picks up the load. This wiring is shown in Figure 3-17.

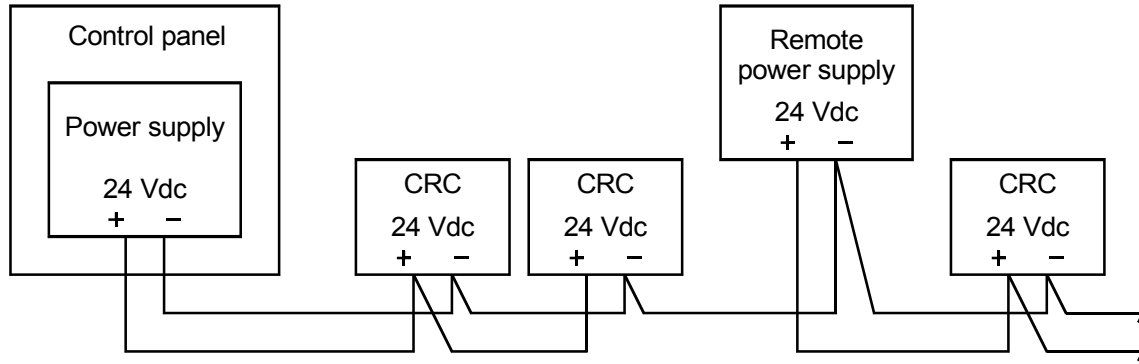

Figure 3-17: Wiring for remote power supply

Power supply

Jumper settings determine the power source and usage for the CRC. Configure the input power as DC. Configure the output power as continuous.

Note that additional power supplies must be listed for fire alarm applications, must have ground fault detection disabled, and must have a circuit ground that is isolated from earth ground.

Hardware configuration

The control panel must contain the following rail modules:

- 3-SSDC(1) Single Signature Controller module
- 3-SAC Security Access Control module
- 3-PPS/M Primary Power Supply module

The 3-SSDC(1) module supports the SIGA loop, which supervises the remote power supply

The 3-SAC module supports the SAC bus. Power for the CRC is normally taken from the 3-PPS/M and is routed with the data lines in a cable composed of two twisted-pair wires. In this case the power from the 3-PPS/M is simply passed through the CRC.

The remote power supply is supervised by the 3-SSDC(1) module via the Signature loop. The remote power supply must share a common ground with the 3-PPS/M.

SDU programming

When programming the system for this application, you'll need to configure the CRC and define the appropriate lock type in the SDU. This can be either a strike or maglock.

Remote controls

Description of the application

In any access control system, a card reader and CRC can be used to operate devices that are completely remote from the CRC. In such cases the CRC simply creates an access event and passes it to the 3-SAC for processing by the CPU. Any device that can be controlled by an EST3 panel can be operated in response to an access event.

As a typical example, Figure 3-18 shows how the entrance devices to a secured parking area could be operated from a remote card reader. Note that any type of CRC input device could be used in place of a card reader.

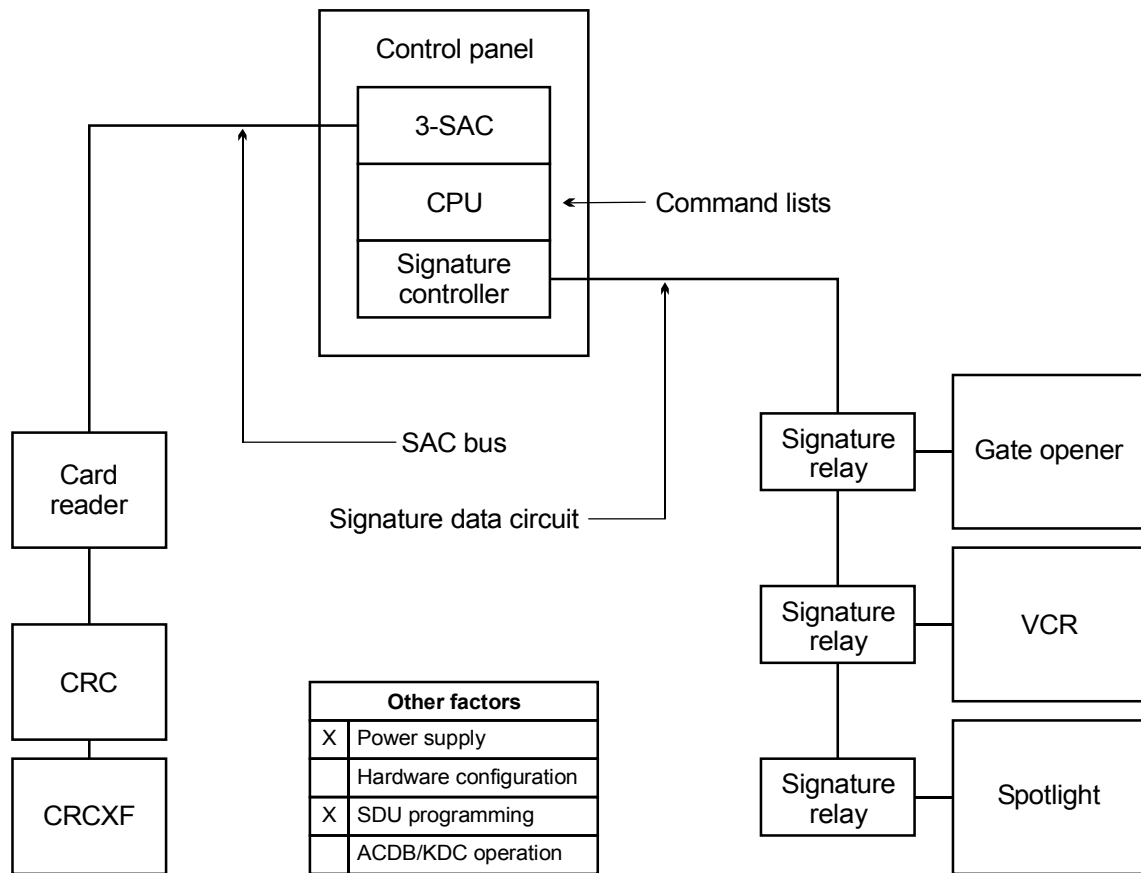

Figure 3-18: Remote control of a parking garage entrance

When the cardholder badges in, the access event is sent from the CRC to the 3-SAC and then to the CPU. At the CPU, the access event activates a predefined command list.

The command list operates the Signature relays on the Signature data circuit supported by the Signature controller module. These relays activate the gate opener, a spotlight, and a VCR image recording system.

An inside card reader and could be used to control exits from the area, but it would be more appropriate to use a motion detector, since egress from the area is not controlled.

Power supply

A CRCXF—CRC Transformer power supply is shown, assuming that the CRC is located at some distance from the electrical room and control panel.

If you use an additional power supply other than the CRCXF, that power supply must be listed for fire alarm applications, must have ground fault detection disabled, and must have a circuit ground (circuit common) that is isolated from earth ground.

SDU programming

The SDU programmer must create a command list that specifies activation of the correct relays and devices, the delays required, and the deactivation of the devices.

Since there is no restoration phase of access events, the command list should include commands that turn off the devices.

Two-person rule

Description of the application

A *two-person rule* ensures that no staff member can be in a controlled area alone. A CRC operating under two-person rule prevents the entrance of a single person into the controlled area. When two people are present in the area, one cannot exit without the other.

The controlled area can have a single entrance or multiple entrances. The network coordinates user information between the CRCs that serve a common area.

A typical two-person rule application is shown in Figure 3-19, below.

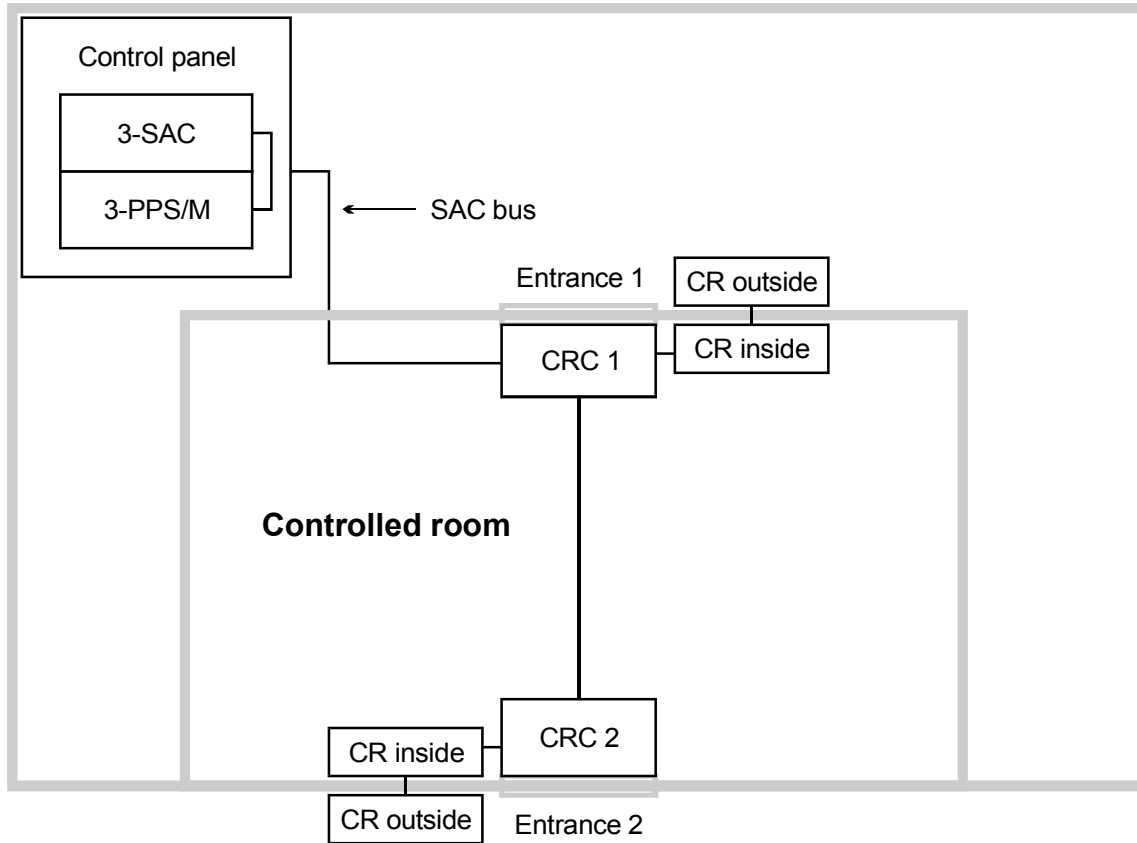

Other factors	
X	Power supply
X	Hardware configuration
X	SDU programming
X	ACDB/KDC programming

Figure 3-19: Two-person rule

Card reader

This application works best with card readers that support dual LED control. The CRC uses the second LED (or LED state) to signal the cardholder that a second person must badge in or out of the controlled area.

Hardware configuration

The control panel must contain the following rail modules:

- 3-SAC Security Access Control module
- 3-PPS/M Primary Power Supply module

The 3-SAC module supports the SAC bus. Power for the CRC is normally taken from the 3-PPS/M and is routed with the data lines in a cable composed of two twisted-pair wires.

SDU programming

If the CRC is to be used for two-person rule it must be configured in the SDU. On the CRC Configuration tab, the 2 Person Rule box must be checked.

You can also assign a predefined command list to the Access Denied 2 Person Timeout event. This setting is found on the CRC Command Lists tab.

Centralized audio applications

Summary

EST3 supports centralized audio. This chapter introduces you to the equipment required, and discusses special installation and backup considerations for centralized audio applications.

Refer to the manual entitled *EST3 Installation Sheets* for specific component settings and terminal connections.

Content

- Equipment required • 4.2
- ATPC Amplifier Terminal Panel Cabinet • 4.3
 - Overview • 4.3
 - Equipment racks • 4.3
- ATP Amplifier Terminal Panel • 4.6
 - Battery backup • 4.7
- Audio amplifiers • 4.8
- URSM Universal Riser Supervisory Module • 4.10
 - Application • 4.10
 - Installation • 4.11
 - Terminal connections • 4.11
 - Operation • 4.11
- ATP installation • 4.13
- ATP wiring • 4.14
- ATP terminal connections • 4.14
- ATP jumper settings • 4.15
- 3-ATPINT terminal connections • 4.15
- 3-ATPINT jumper settings • 4.16
- ATP external battery charger • 4.20
- Amplifier backup • 4.22
- Branch speaker wiring • 4.25
- Troubleshooting • 4.27

Equipment required

The EST3 system requires one 3-ZA20 amplifier for each audio channel to be operated *simultaneously*. The output of each amplifier is reduced from 25 Vrms to the appropriate input level (1 Vrms) using the 3-ATPINT interface, and then fed into the input of the banked amplifiers.

The wiring between the output of each 3-ZA20 and its associated amplifier bank input should be twisted, shielded pair, and can be configured for Class A or Class B integrity monitoring.

The output of the banked amplifiers (the audio riser) is directed to the appropriate areas using Signature Series modules. The SIGA-CC1 module, Figure 4-16, is used for single channel systems and the SIGA-CC2 module, Figure 4-17, is used for two channel systems.

EST3 audio system programming requires that the Signature modules controlling the audio signals be programmed in addition to the programming required for the 3-ZAxx amplifier(s) supplying the audio signal.

Note: Remember to follow power-limited or nonpower-limited wiring practices as determined by the amplifier providing the audio signal.

ATPC Amplifier Terminal Panel Cabinet

Overview

The Amplifier Terminal Panel (ATP), the 3-ATPINT Interface, RKU series enclosures, and Dukane 125 W or 250 W audio power amplifiers are the basic components of the Amplifier Terminal Panel Cabinet (ATPC). Appropriately sized standby batteries, and in some situations an external battery charger, round out the equipment required in the ATPC. The ATPC can be located up to 3,000 ft (914 m) from the 3-ZAxx amplifiers supplying the audio signals.

Equipment racks

RKU-Series Equipment Racks are designed to support standard 19 in (48.26 cm) wide rack-mount components. These UL listed enclosures are constructed of 16 gauge steel, and finished in either white or black enamel.

Interior-facing louvers on the two side panels and the back door provide ventilation for installed equipment, while maintaining a flush outside surface for side-by-side stacking of multiple racks. Six conduit knockouts for 1/2 in or 3/4 in conduit are available on the top end panel (three on top, three on the flange), and six on the bottom end panel (three on the bottom and three on the flange). Three 2.875 in (7.3 cm) diameter cable access holes are located on the bottom end panel for routing wiring to cabinet components. The equipment mounting rails on the front of the rack are recessed 0.625 in (1.59 cm).

The louvered back door attaches to the cabinet with spring hinges allowing easy field access and door removal. A key lock is provided on the door for added security. Multiple racks can be installed side by side where additional cabinet capacity is required.

The RKU series of 19 in (48.3 cm) equipment racks is used to house the banked amplifiers and associated equipment. Five sizes of racks are available to meet all requirements. These are listed in Table 4, below.

Table 4-1: RKU enclosure specifications

Model	Width	Height	Depth	Rack Space
RKU-36(B)	22.31 in (56.7 cm)	41.06 in (104.3 cm)	18.50 in (47.0 cm)	36.75 in (93.3 cm)
RKU-42(B)	22.31 in (56.7 cm)	46.31 in (117.6 cm)	18.50 in (47.0 cm)	42.00 in (106.7 cm)
RKU-61(B)	22.31 in (56.7 cm)	65.56 in (166.5 cm)	18.50 in (47.0 cm)	61.25 in (155.6 cm)
RKU-70(B)	22.31 in (56.7 cm)	74.31 in (188.7 cm)	18.50 in (47.0 cm)	70.00 in (177.8 cm)
RKU-77(B)	22.31 in (56.7 cm)	81.31 in (206.5 cm)	18.50 in (47.0 cm)	77.00 in (195.6 cm)

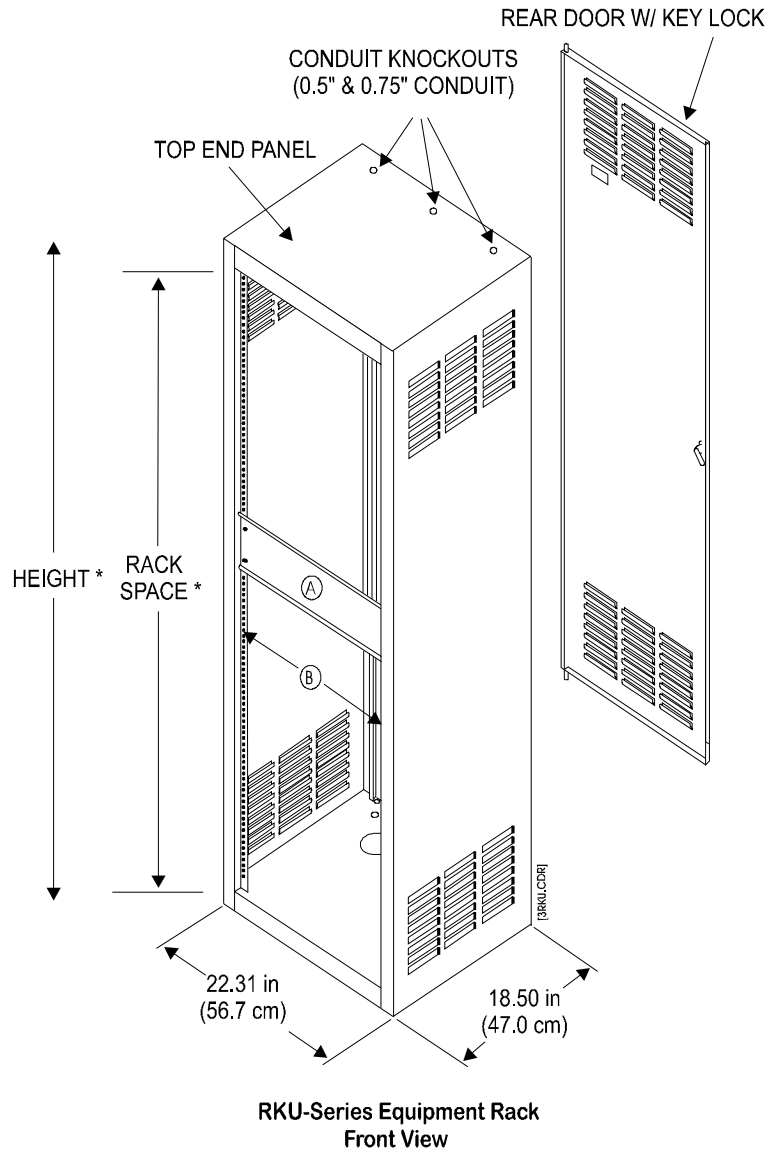

* Refer to Text for Dimensions

(A) = SUPPORT BAR

(B) = 19" RACK MOUNT

Figure 4-1: RKU Equipment Rack

ATP Amplifier Terminal Panel

A 3-ATPINT Interface must be installed on the ATP when used with the EST3 system.

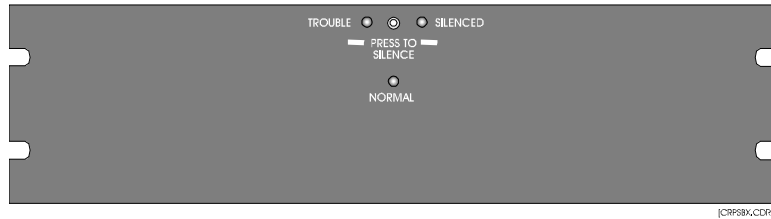

Figure 4-2: 3-ATP, front view

The Amplifier Terminal Panel, is a 5-1/4 inches (13.34 cm) high x 19 inches (48.3 cm) wide unit that senses loss of AC power or brownout conditions affecting the amplifiers. It also provides battery backup to the amplifiers if the audio system is active when the power failure or brownout occurs. The ATP must have a 3-ATPINT interface Card installed in order to work with the EST3 system.

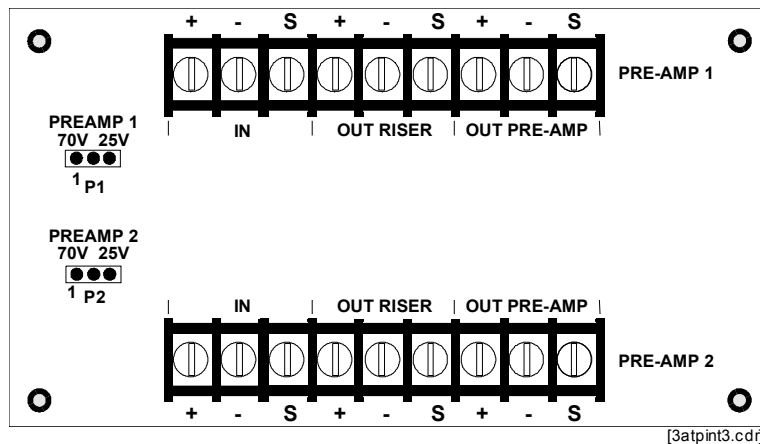

Figure 4-3: 3-ATPINT Interface Card

The ATP with 3-ATPINT installed, is mounted in an RKU rack and provides termination for the power amplifier's audio power and control signals. The panel has an integral battery charger capable of charging a maximum of 40 Ah sealed, lead-acid batteries. The charger is fully supervised and provides a silenceable trouble buzzer and trouble contacts. One ATP is required for every two amplifiers.

When a brownout condition is sensed at the ATP, the trouble contacts and AC fail contacts are closed, and an EST3 supervisory zone reports the condition to the EST3 system. The EST3 system is designed to provide +24 Vdc to the ATP's audio activity input via control relay, enabling backup power only when *both* primary

power to the amplifiers has failed *and* the EST3 audio is active during an alarm condition.

Battery backup

When multiple ATPs share a common battery, an external battery charger must be used.

To charge the batteries, you will use either the ATP's integral battery charger or an external LaMarche model A33-10-24 battery charger.

The internal battery charger is capable of charging 40 Ah batteries.

Caution: Do *not* connect the battery chargers of multiple ATPs in parallel to increase charger current.

When multiple ATPs share a common battery, or when the amplifier backup is to be supplied from a single battery source, a LaMarche model A33-10-24 external battery charger must be used. The Amplifier Terminal Panel switches battery power to the amplifiers.

When calculating the battery size required to support the amplifiers, the alarm current must be known. Each 250 W amplifier connected to the system draws 20 amperes at 24 Vdc at full load; 125 W amplifiers draw 10 amperes at 24 Vdc at full load.

The amplifiers draw no current in the standby mode. NFPA 72 specifies that designing the system to provide 15 minutes of the evacuation alarm at full load is the equivalent of 2 hours of emergency operation. The local authority having jurisdiction or local codes can modify the amount of time for which standby power must be provided.

Audio amplifiers

Two Dukane amplifiers are available. Model 1B3125 is rated at 125 watts output. Model 1B3250 is rated at 250 watts output. Both amplifiers operate from 120 Vac, 50/60 Hz, as well as 24 Vdc battery backup. The amplifiers are mounted in an Amplifier Terminal Panel Cabinet.

Note: The Model 1B3250 amplifier should be loaded to no more than 72% of rated capacity. The amp is derated by 28% to allow for continuous operation and line loss averages.

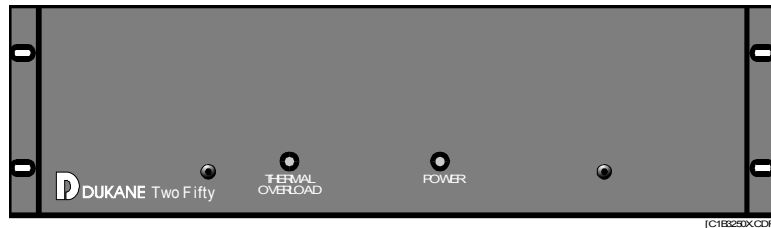

Figure 4-4: Dukane 250-watt Amplifier, Front View

Table 4-2: 1B3125 Amplifier specifications

Rated output power	125 W
Max. signal input	1 Vrms
Input impedance	75 kΩ
Output voltage	25 or 70 Vrms
Primary power	120 Vac, 60 Hz
Battery power	24 Vdc
AC power consumption standby	27 W
full load	360 W
DC power consumption standby	0 W (when using the ATP)
full load	11.5 A
Dimensions (HWD)	5.25 x 19.0 x 6.625 in (13.3 x 48.3 x 16.8 cm)
Weight	22.5 lb (10.1 kg)

Table 4-3: 1B3–250 Amplifier specifications

Rated output power	250 W (180 W max. loaded)
Max. signal input	1 Vrms
Input impedance	75 kΩ

Table 4-3: 1B3–250 Amplifier specifications

Output voltage	25 or 70 Vrms
Primary power	120 Vac, 60 Hz
Battery power	24 Vdc
AC power consumption standby	48 W
full load	700 W
DC power consumption standby	0 W (when using the ATP)
full load	20 A
Dimensions (HWD)	8.5 x 19 x 15 in (21.6 x 48.3 x 38.1 cm)
Weight	55 lb (24.9 kg)

URSM Universal Riser Supervisory Module

The Universal Riser Supervisory Module (URSM) provides open and short circuit, and amplifier supervision of two risers, audio (25 or 70 Vrms), and/or firefighter telephone riser. A form C dry relay contact is provided for each riser circuit's trouble annunciation. Ground fault detection is also provided for the risers using a GFD Ground Fault Detector.

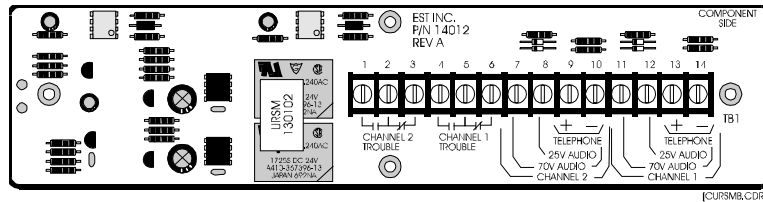

Figure 4-5: URSM

Application

The URSM is required on 70 Vrms audio system risers, and 25 Vrms audio systems. The URSM should be located in an equipment cabinet convenient to the end of the risers, which has 24 Vdc power available. URSM trouble contacts should be monitored with a SIGA-CT2 module to signal riser trouble information back to the network.

The URSM riser inputs should be connected to a GFD, which provides ground fault monitoring. The GFD should be monitored with a SIGA-CT1 module to signal riser ground fault conditions back to the network. The GFD and SIGA-CT1 must be installed in the same enclosure and should be located adjacent to the fire alarm control panel.

Table 4-4: URSM specifications

Voltage	24 Vdc
Standby Current	40 mA
Trouble Contact Rating	30 Vdc @ 2A
Trouble Detection Levels	
25 Vrms audio	10 Vrms
70 Vrms audio	23 Vrms
Firefighter's phone	2.7 Vrms

Installation

The URSM requires one-half of a standard mounting footprint and should be installed where the power pigtails can reach the power supply.

The GFD and CT1 must be installed in the same enclosure, located adjacent to the fire alarm control panel. Jumper JP1 on the GFD should be set to the 2-3 position.

Terminal connections

Refer to Figure 4-6.

Black pigtail = (-)24 Vdc power in

Red pigtail = (+)24 Vdc power in

TB1-1 to 3 = Channel 2, trouble relay contacts

TB1-4 to 6 = Channel 1, trouble relay contacts

TB1-7 = Channel 2, 70 Vrms audio riser input

TB1-8 = Channel 2, 25 Vrms audio riser input

TB1-9 = Firefighter's Telephone riser input, Ch 2

TB1-10 = Channel 2, Riser input, common

TB1-11 = Channel 1, 70 Vrms audio riser input

TB1-12 = Channel 1, 25 Vrms audio riser input

TB1-13 = Firefighter's Telephone riser input, Ch 1

TB1-14 = Channel 1, Riser input, common

Operation

The trouble relay will activate 45–60 seconds after a circuit short, circuit open, or amplifier failure is detected.

Centralized audio applications

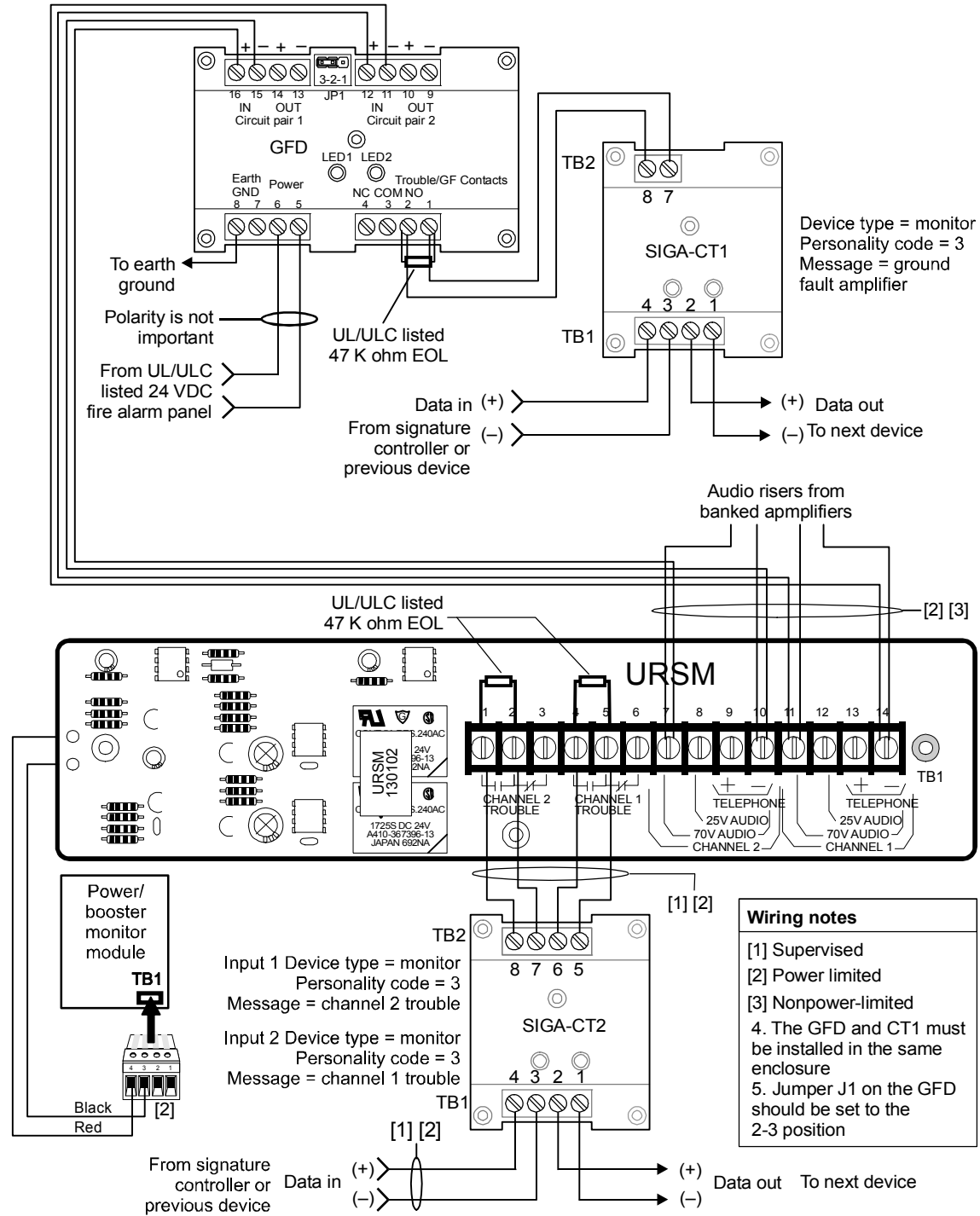

Figure 4-6: URSM wiring

ATP and 3-ATPINT installation

ATP installation

Refer to Figure 4-7.

To install the ATP:

1. Remove the cover plate from the left side of the ATP. The cover plate is held in place by four screws.
2. Install four short spacers [5] in the flanges of the card cage, and secure with nuts [6].
3. Mount the 3-ATPINT board [4] on the four short spacers [5] and secure with four long spacers [3].
4. Install the new cover plate [2] on the long spacers with the screws [1] provided.

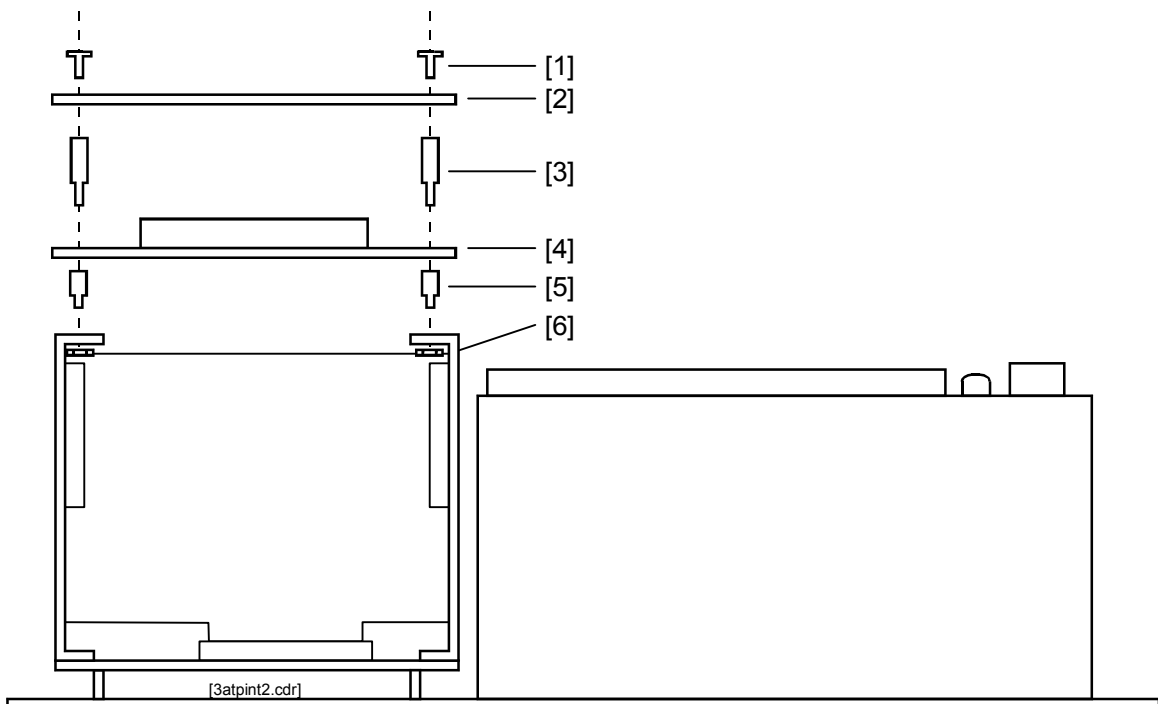

Figure 4-7: 3-ATPINT installation, bottom view

ATP wiring

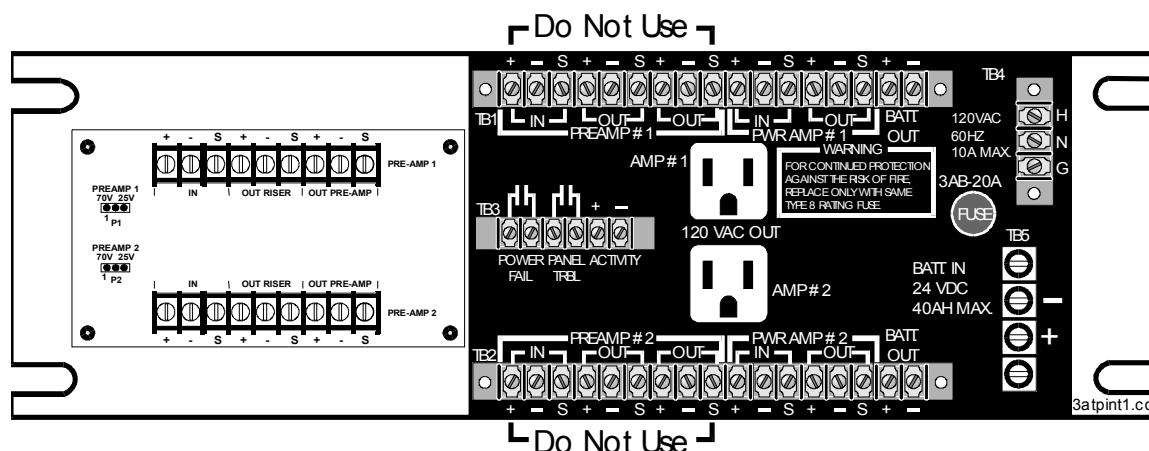

Figure 4-8: ATP with 3-ATPINT installed, rear view

ATP terminal connections

AMP POWER 1 = Type NEMA 5–15p receptacle to plug in one amplifier. Output is rated at 120 Vac, 5 A max.

AMP POWER 2 = Type NEMA 5–15p receptacle to plug in one amplifier. Output is rated at 120Vac 5 A max.

BATT IN - These terminals are for connection of gel cell batteries. When the internal battery charger is enabled (J3 on the APSB terminal board installed) a maximum of 40 Ah of gel cell batteries can be charged.

POWER FAIL - Normally open that activates when primary power to the amplifiers is either lost or in brownout condition. This contact is to be supervised by Signature series input module configured as a supervisory input.

PANEL TROUBLE - Normally open relay contacts that close when any of the following power problems are sensed:

- Loss of 24 Vdc power
- Failure of the battery charger circuit (if enabled)
- Any blown fuse or circuit breaker
- Ground fault, if enabled

ACTIVITY = 24 Vdc should be provided to these terminals through SIGA-CR contacts when either an alarm is present in the system or when the system user activates the paging system. When this input is active and the amplifier is in power fail, power relay contacts will transfer and provide battery power to the terminals marked BATT OUT. Each battery output terminal is capable of providing 20 A of battery current.

In addition to the terminals listed above, two groups of terminals are provided for connection of audio signals, one for each channel

WARNING: Do not use the preamp in and out terminals on the main body of the ATP if the 3-ATPINT Interface is installed. Route *all* preamp wiring to the 3-ATPINT.

The following terminals are provided on the ATP for audio channel 1 and channel 2.

PREAMP IN = Not used. Refer to 3-ATPINT terminal connections.

PREAMP OUT = Not used. Refer to 3-ATPINT terminal connections.

PREAMP OUT = Not used. Refer to 3-ATPINT terminal connections.

AMP IN = From the 70 V or the 25 V output of the power amplifier.

AMP OUT = to be connected to the Signature Series control modules and terminated with a URSM Universal Riser Supervisory Module. The URSM must be monitored by a Signature Series input module configured as a supervisory circuit. Each riser cannot supply a load greater than 180 W.

ATP jumper settings

Refer to Figure 4-9.

Table 4-5: 3-ATP Jumper Settings

Function	Jumper Setting
Ground fault detection	J1 = enable
No ground fault detection	J1 = disable
Internal battery charger operable	J2 = in
Internal battery charger disabled	J3 = in

3-ATPINT terminal connections

Refer to Figure 4-9.

IN RISER = To audio source amplifier 25 or 70 Vrms output, or previous 3-ATPINT riser output.

OUT RISER = 25 or 70 Vrms output to next 3-ATPINT IN RISER or EOL resistor.

OUT PRE-AMP = Low level audio to audio power amplifier input.

3-ATPINT jumper settings

Refer to Figure 4-9.

Table 4-6: 3-ATPINT jumper settings

Input / Voltage	Jumper setting
Pre-Amp #1, 70 Vrms	P1 = 1/2
Pre-Amp #1, 25 Vrms	P1 = 2/3
Pre-Amp #2, 70 Vrms	P2 = 1/2
Pre-Amp #2, 25 Vrms	P1 = 2/3

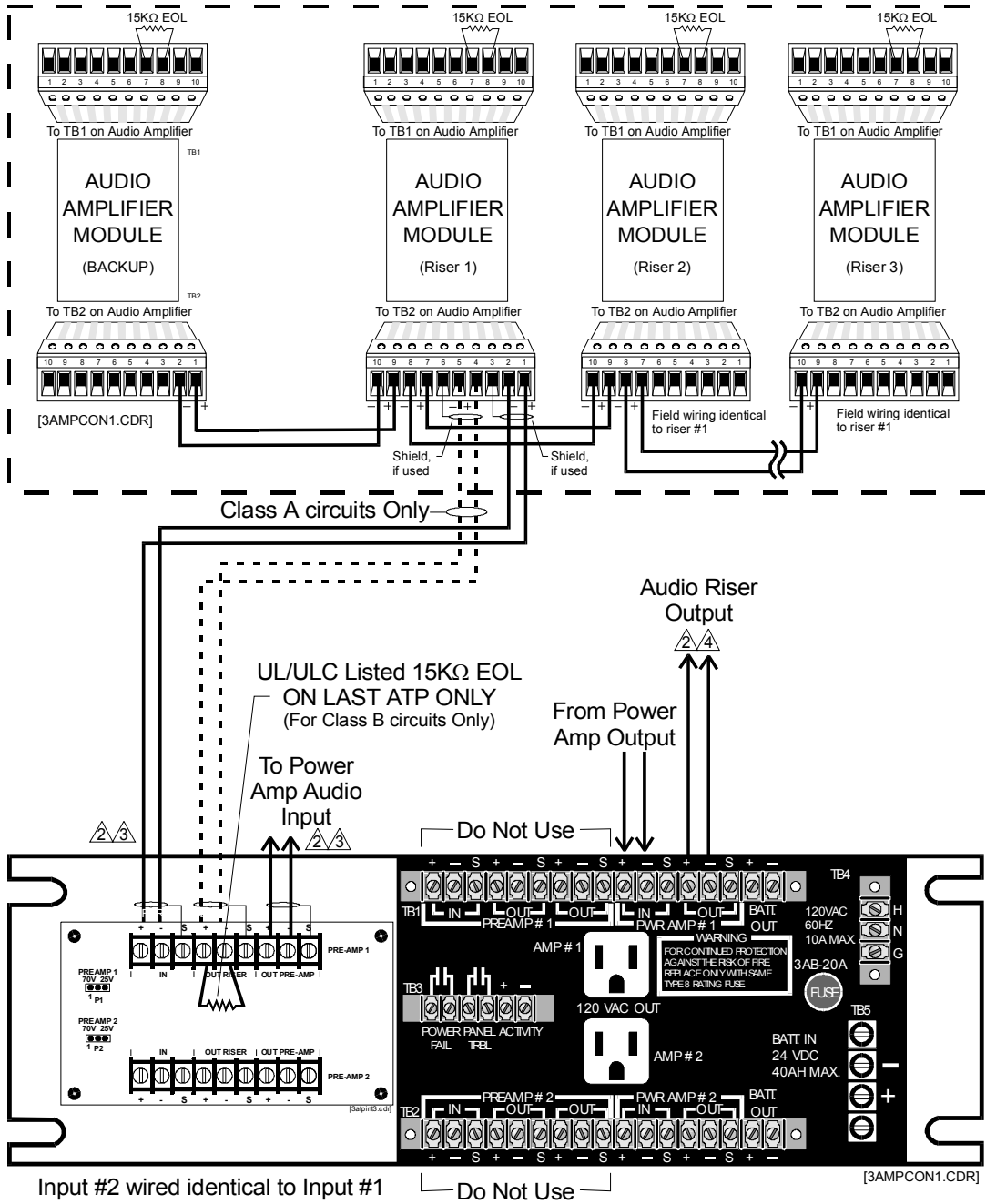

JUMPER SETTINGS
 P1 = 1/2, Pre-Amp #1 Input 70 V_{RMS}
 P1 = 2/3, Pre-Amp #1 Input 25 V_{RMS}
 P2 = 1/2, Pre-Amp #2 Input 70 V_{RMS}
 P2 = 2/3, Pre-Amp #2 Input 25 V_{RMS}

- Wiring Notes**
1. Circuit polarity shown in supervisory condition.
 - ⚠ Supervised circuit.
 - ⚡ Power limited circuit.
 - ⚡ Non-Power limited circuit.
 5. Back up amplifier size must equal the wattage of the largest amplifier to be backed up.
 6. Set J1 & J2 to match source amplifier output voltage.
 7. Additional ATPs may be connected to the same audio source by connecting the ATP pre-amp output to the pre-amp input of the next ATP.

Figure 4-9: ATP with 3-ATPINT wiring

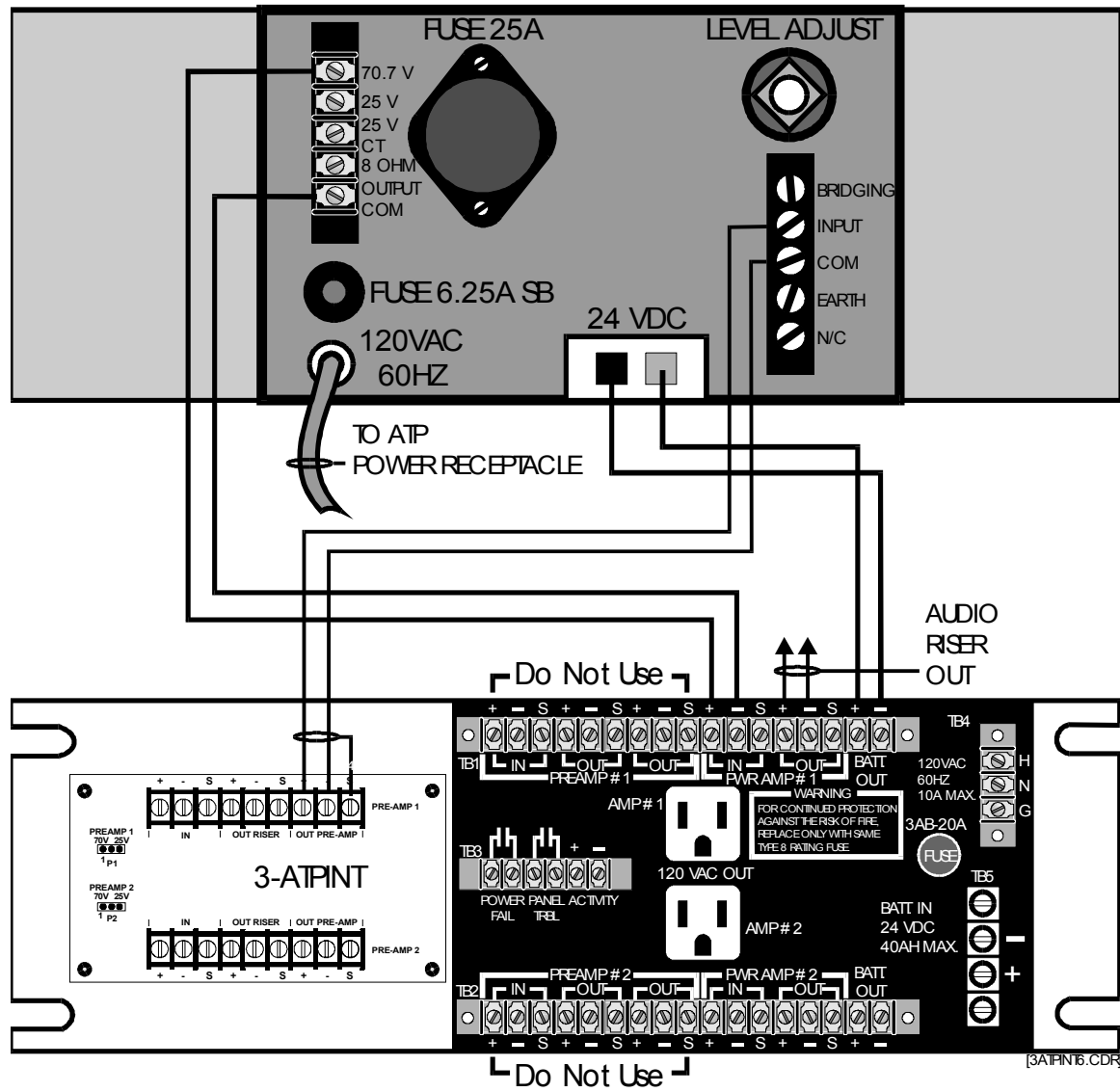
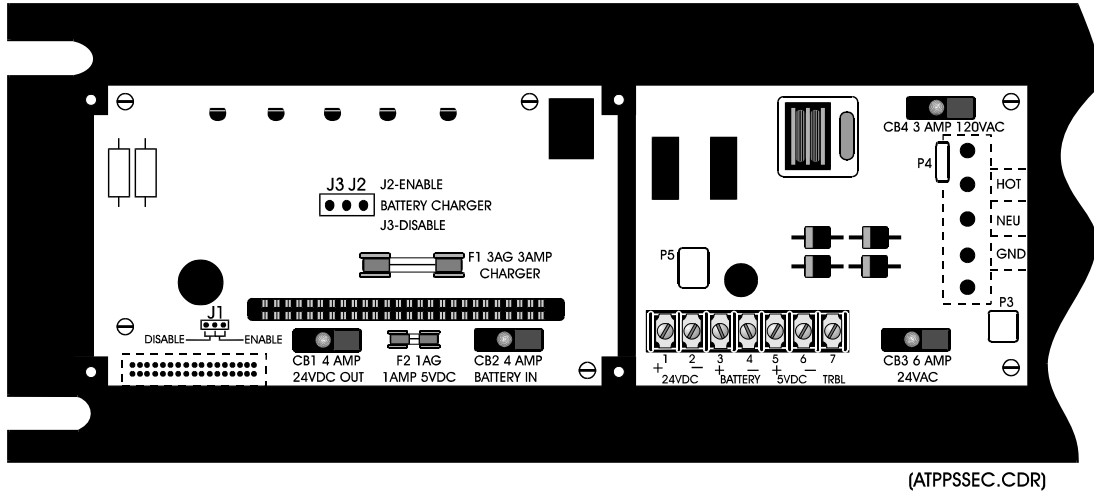

Figure 4-10: Wiring from Dukane amplifier to ATP



(ATPPSSEC.CDR)

Figure 4-11: Power supply terminal card, with 3-ATPINT, cover removed

The output of the amplifier must be set for the proper value by adjusting the INPUT LEVEL adjustment on the back of the amplifier. With a 1,000 Hz tone generated by the 3-ACPor 3-ZA20, the amplifier must be adjusted for 70 Vrms output using the appropriate RMS voltmeter.

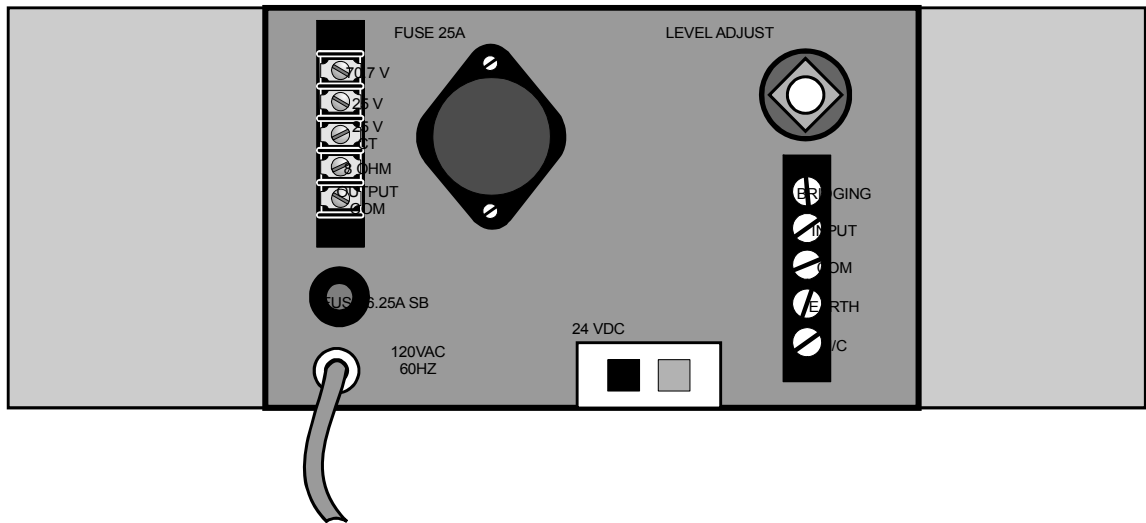

Figure 4-12: Dukane amplifier, rear view

ATP external battery charger

When multiple ATPs are connected to a common battery set, disable the ATP internal battery charger, by installing J3 and removing J2 on the APSB terminal board. This is located in the ATP. (see Figure 4-11). Use a La Marche model A33-10-24 external battery charger, which can charge up to 160-Ah batteries, as shown in Figure 4-13.

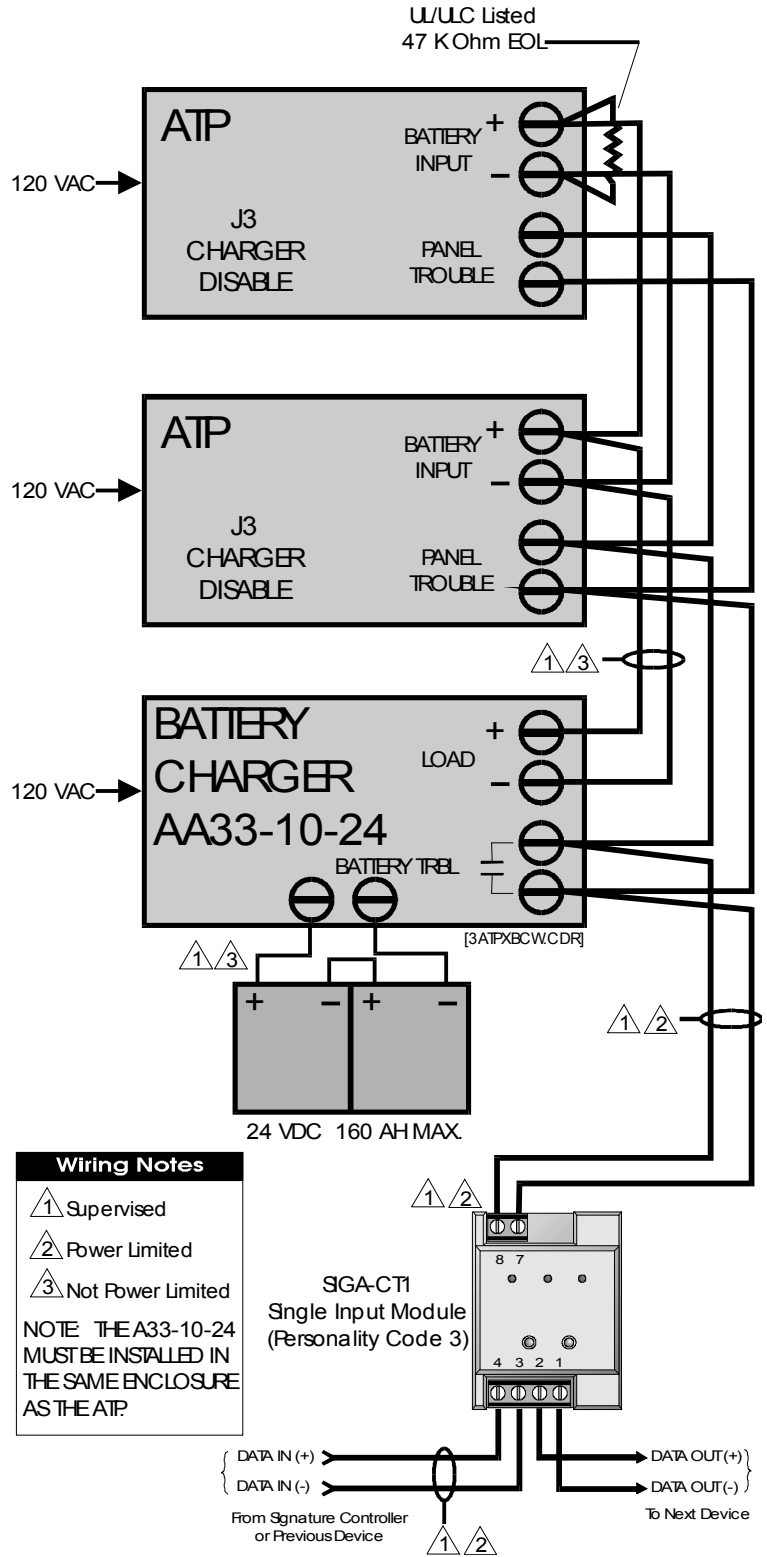
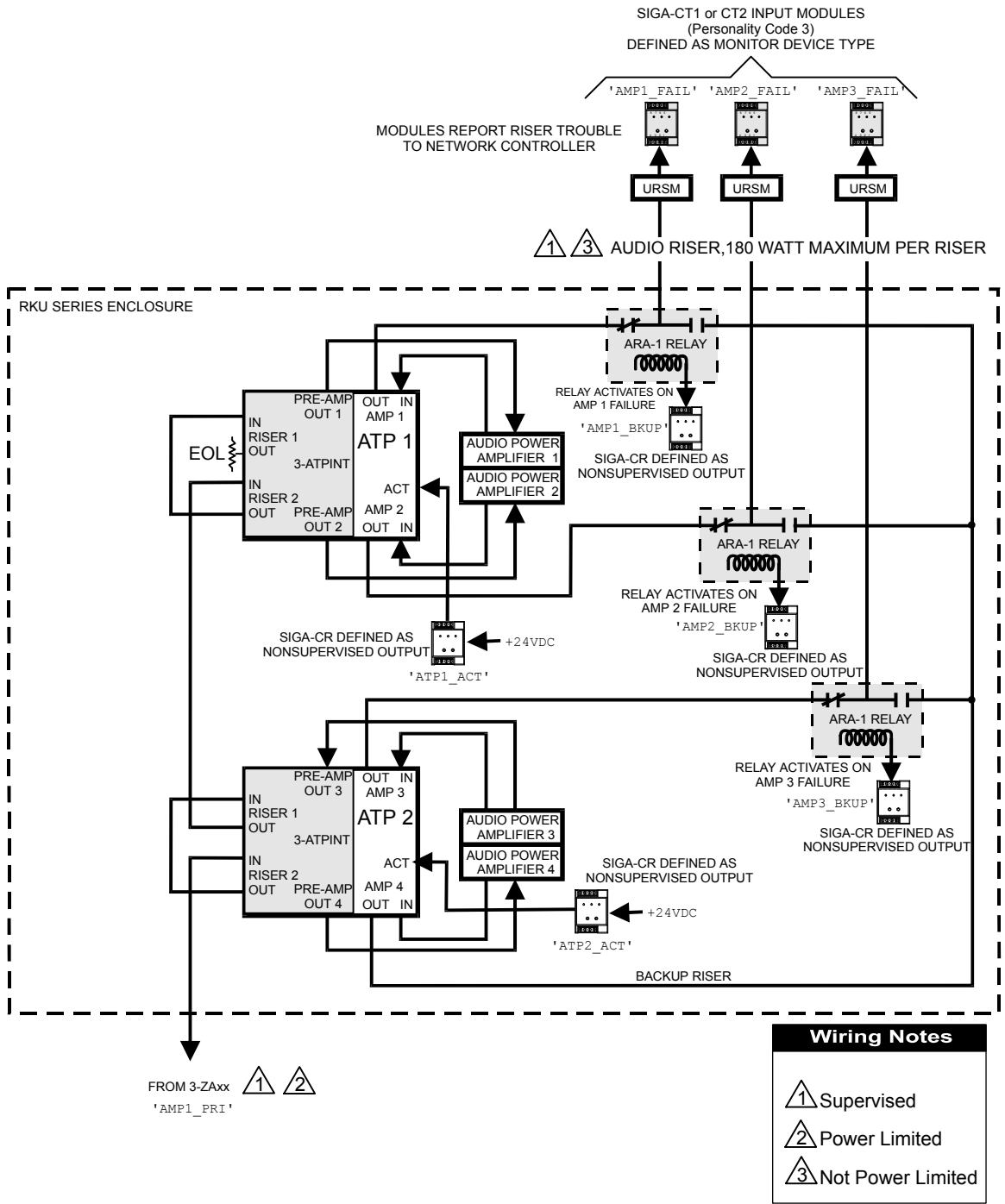

Figure 4-13: ATP external battery charger wiring

Amplifier backup

Various methods are available to provide a spare amplifier in the event that a primary amplifier fails. Depending upon the local Authority Having Jurisdiction, a single backup amplifier can be required for each primary amplifier or a single backup per bank of amplifiers.



(3ATPINT5.CDR)

Figure 4-14: Amplifier bank with spare amplifier

Centralized audio applications

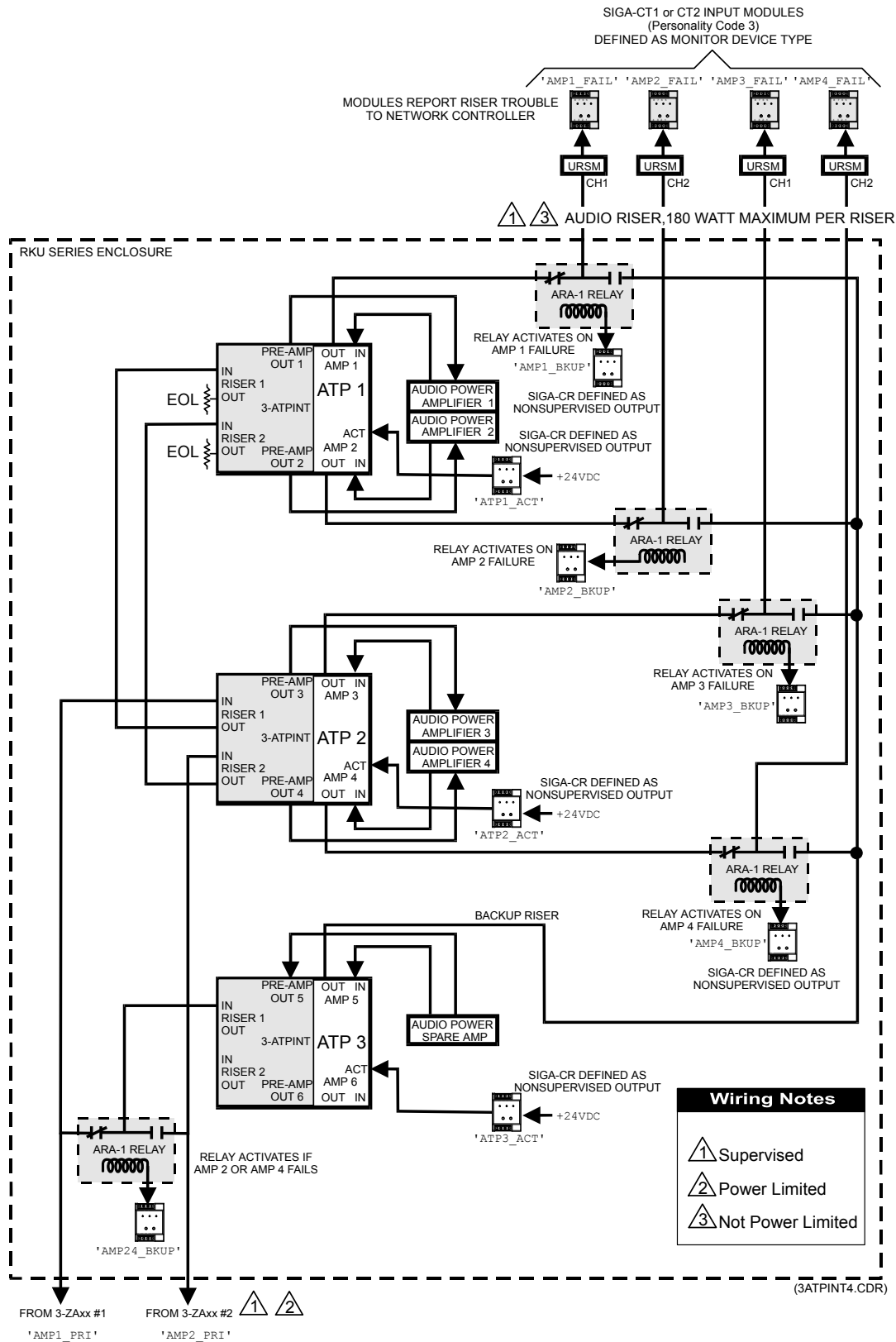

Figure 4-15: One spare amplifier in dual channel system

Branch speaker wiring

Signature modules are used to connect individual floor branch speaker circuits to the main riser. Single channel branch speaker circuits can be wired as Class A (Style Z) using the SIGA-UM module. Class B (Style Y) circuit configuration can be accomplished using either the SIGA-UM or SIGA-CC2 modules. The branch speaker circuits of two channels can be wired as Class B (style Y) circuits using the SIGA-CC2 module.

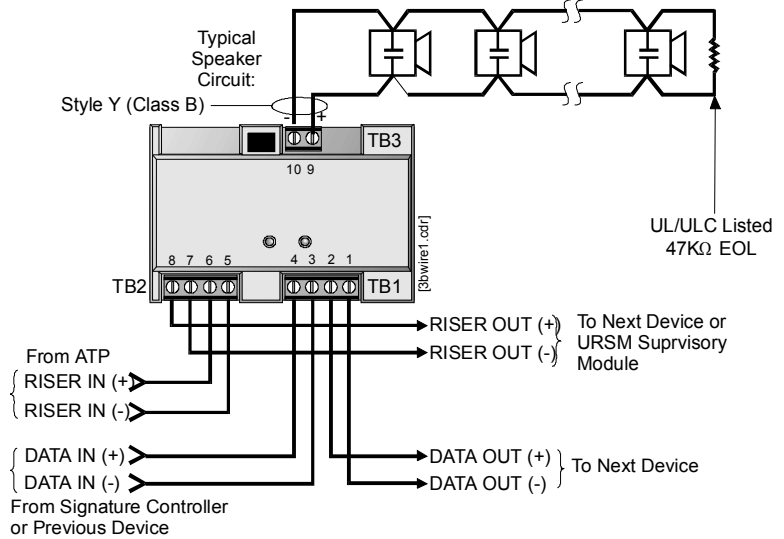

Figure 4-16: Single channel Class B wiring, SIGA-CC1 Module

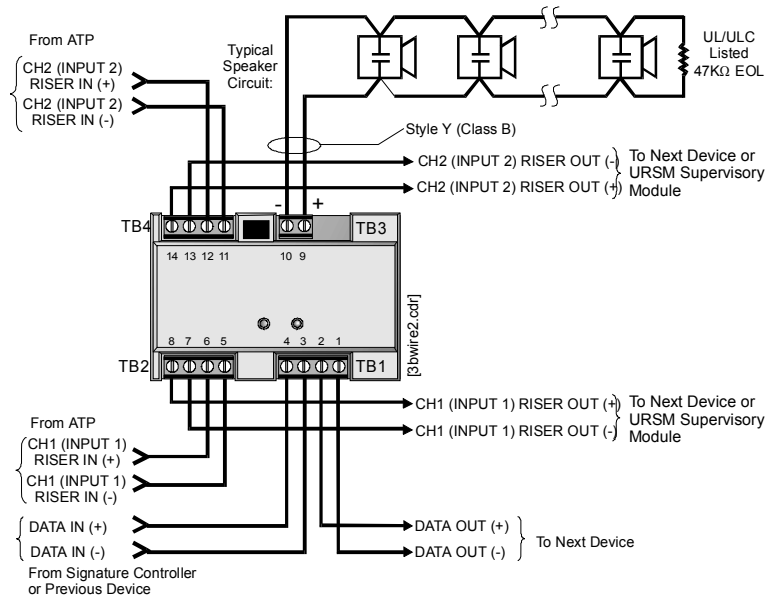

Figure 4-17: Two channel Class B wiring, SIGA-CC2 Module

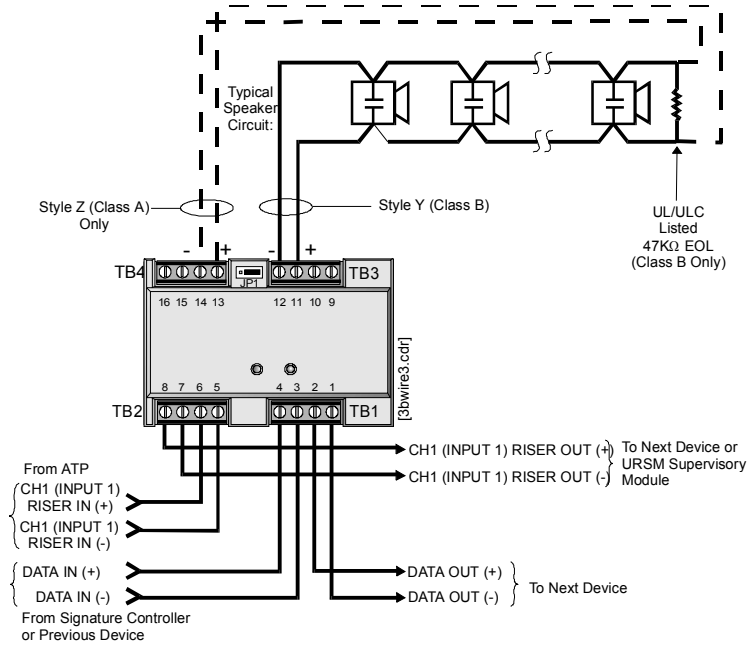

Figure 4-18: Single channel Class A wiring, SIGA-UM Module

Troubleshooting

The ATP senses loss of AC power or brownout conditions affecting the amplifiers. It also provides battery backup to the amplifiers if the audio system is active when the power failure or brownout occurs. The ATP must have a 3-ATPINT interface Card installed in order to work with the EST3 system.

The ATP enters a trouble state if any of the following events occur:

- ATP brownout or loss of AC power
- Low battery charge or missing battery (with J2 enabled)
- Ground fault (if ground fault detection J1 is enabled)
- Fuse failure

Centralized audio applications

Summary

This chapter provides installation information for system components and applications that supplements the instructions provided on individual component installation sheets.

Content

- Installation overview • 5.3
 - Electrostatic discharge precaution • 5.3
 - Energized system precaution • 5.3
 - Circuit compatibility • 5.3
 - Recommended cable manufacturers • 5.4
- UL 864 NAC signal synchronization • 5.6
 - Requirements • 5.6
 - Typical circuits • 5.8
- Creating an initial startup version of the project database • 5.16
- System installation sequence • 5.18
- Preliminary field wiring testing • 5.19
- Chassis installation in EIA 19-inch racks • 5.22
- ATCK Attack Kit for cabinets • 5.23
- Local rail module installation • 5.24
- 3-MODCOM Modem Communicator module • 5.26
 - Features • 5.26
 - Functions • 5.27
 - Equipment • 5.28
 - Configuration options • 5.29
 - Failover operation • 5.30
 - Compatibility • 5.32
 - Transmission protocols • 5.32
 - Transmission process • 5.33
 - Programming considerations • 5.35
 - Installation • 5.36
- 3-SAC Security Access Control module • 5.40
 - Product description • 5.40
 - SAC bus • 5.40
 - Recommended cabling • 5.40
 - Additional power supply wiring • 5.40
- 3-AADC1 Addressable Analog Driver Controller and IRC-3 • 5.41
- AC power and DC battery wiring • 5.42
- Connecting auxiliary/booster power supplies • 5.44
 - Installation • 5.44
 - Configuration • 5.44
- Connecting the PT-1S impact printer • 5.46
 - System printer power supply • 5.48
- Adjusting amplifier output levels • 5.49
 - What you will need • 5.49
 - Adjustment procedure • 5.49

Installation

- Design considerations • 5.49
- Connecting a CDR-3 Zone Coder for coded tone output • 5.50
 - What you will need • 5.50
 - Adjusting the gain on the 3-ASU auxiliary input • 5.50
- Connecting an external modem for use with the Remote Diagnostics Utility • 5.53
- Running the RPM and distributing profiles • 5.55

Installation overview

Electrostatic discharge precaution

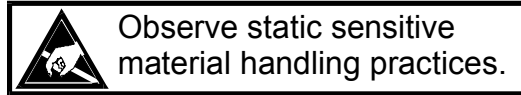

The components used in this system are sensitive to electrostatic discharge (ESD). When handling electronic assemblies, you must take precautions to avoid the build up of static charges on your body and on the equipment.

- Do not open the anti-static packaging until you are ready to install the electronics.
- Wear a grounded wrist strap to bleed off any static charge which may have built up on your body.

Energized system precaution

Caution: Never install or remove a module or cabinet component with power applied to the cabinet.

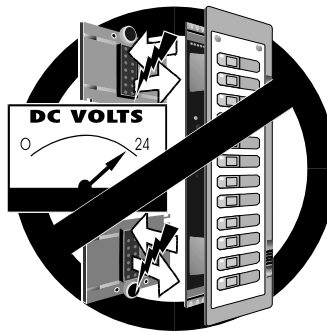

Circuit compatibility

The following circuit compatibility matrix indicates which circuit types may occupy the same conduit or be bundled together, where permitted by code.

CIRCUIT COMPATIBILITY MATRIX

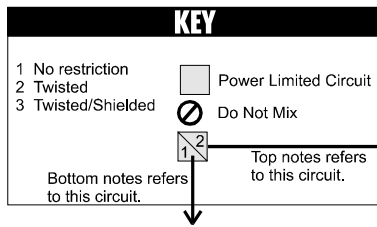

Circuits permitted by manufacturer to occupy the same conduit. Check local codes for additional restrictions.

WMATRIX2.CDR

	24 VDC-power limited	Network Audio-digitized	Network Com (RS-485)	25 V _{RMS} Audio-power limited	25 V _{RMS} Audio-not power limited	70 V _{RMS} Audio-power limited	70 V _{RMS} Audio - not power limited	Signature Data Circuit	Addressable Analog "ZAS" Circuit	Traditional 2-Wire IDC	RS-232 Peripheral Data Circuit	Telephone	AC Mains - not power limited	Fiber Optic Cable	Circuit Wiring Specifications
24 VDC-power limited	1	1	2	2	1	1	1	2	1	2	1	3	1	1	Size conductors per acceptable voltage drop.
Network Audio-digitized	2	1	2	2	2	2	2	2	2	2	2	3	2	1	Max. Ckt. Res = 70Ω, NO T-Taps Max. Ckt. Capacitance = 0.07μF.
Network Com (RS-485)	2	1	2	2	2	2	2	2	2	2	2	3	2	1	Max. Ckt. Res = 90Ω, NO T-Taps Max. Ckt. Capacitance = 0.3μF.
25 V _{RMS} Audio-power limited	1	1	2	2	2	2	2	2	2	2	2	3	2	1	Size conductors per acceptable voltage drop.
25 V _{RMS} Audio-not power limited	2	2	2	2	2	2	2	2	2	2	2	3	2	1	Size conductors per acceptable voltage drop.
70 V _{RMS} Audio-power limited	1	1	2	2	2	2	2	2	2	2	2	3	2	1	Size conductors per acceptable voltage drop.
70 V _{RMS} Audio - not power limited	2	2	2	2	2	2	2	2	2	2	2	3	2	1	Size conductors per acceptable voltage drop.
Signature Data Circuit	1	1	2	2	2	2	2	2	2	2	2	3	2	1	Max. Ckt. Res = 76Ω. Max. Ckt. Capacitance = 0.5μF.
Addressable Analog "ZAS" Circuit	2	1	2	2	2	2	2	2	2	2	2	3	2	1	Max. Ckt. Res = 36 w/RZB; 50Ω w/o RZB. Max. Ckt. Capacitance = 0.2μF.
Traditional 2-Wire IDC	1	1	2	2	2	2	2	2	2	2	2	3	2	1	Max. Ckt. Res = 50Ω.
RS-232 Peripheral Data Circuit	2	1	2	2	2	2	2	2	2	2	2	3	2	1	Max. length 50 Ft. (15.2 M) without modem.
Telephone	3	1	2	2	2	2	2	2	2	2	2	3	2	1	#18 AWG Twisted/Shielded. 4,000 Ft. (1,220 M) Max
AC Mains - not power limited	2	2	2	2	2	2	2	2	2	2	2	3	2	1	230V, 20A Max.
Fiber Optic Cable	1	1	2	2	2	2	2	2	2	2	2	3	2	1	Jacket material must be rated for application.

Recommended cable manufacturers

Atlas Wire and Cable Corp.
133 S. Van Norman Road
Montebello, CA 90640
(213) 723-2401

West Penn Wire Corp.
2833 West Chestnut Street
P.O. Box 762
Washington, PA 15301
(412) 222-7060

Belden Wire and Cable Corp.
P.O. Box 1980
Richmond, IN 47375
(317) 983-5200

BSCC
233 Florence Street
Leominster, MA 01453
Telephone: (508) 537-9138
Fax: (508) 537-8392

Remeo Products, Inc.
186 North Main Street
Florida, NY 10921

Table 5-1: Recommended cable manufacturer's part numbers

MFG	Type	#14 (1.50 mm ²) Twisted Pair		#16 (1.00 mm ²) Twisted Pair		#18 (0.75 mm ²) Twisted Pair	
		Unshielded	Shielded	Unshielded	Shielded	Unshielded	Shielded
ATLAS	FPL	218-14-1-1TP	218-14-1-1STP	218-16-1-1STP	218-16-1-1STP	218-18-1-1TP	218-18-1-1STP
	FPLP	—	1762-14-1-2J	1761-16-1-2J	1762-16-1-2J	1761-18-1-2J	1762-18-1-2J
BELDEN	FPL	9580	9581	9572	9575	9571	9574
	FPLP	—	83752	—	—	—	—
BSCC	FPL	—	231402	—	241602	—	241802
	FPLP	341402	—	341602	351602	341802	351802
REMEE	FPLP	NY514UH	NY514SH	NY516UH	NY516SH	NY518UH	NY518SH
WEST PENN	FPL	994	995	990	991	D9780	D975
	FPLP	60993	60992	60991	60990	60980	60975

UL 864 NAC signal synchronization

Requirements

Table 5-2 lists the installation requirements for systems that must meet UL 864 NAC signal synchronization requirements.

Table 5-2: Installation requirements for UL 864 signal synchronization

Circuit	Installation requirements
3-ASU audio riser	The 3-ASU audio subsystem uses a single signal source, so audible NACs on the 3-ASU network audio riser are synchronized network-wide.
3-AADC(1)	<p>Signals are synchronized for a NAC when you use a riser selection module, a Genesis Signal Master synchronization module, and Genesis or Enhanced Integrity notification appliances. Separate NACs on the loop are not synchronized.</p> <p>Configure the audible notification appliances for temporal or steady output as desired.</p>
3-IDC8/4	<p>Signals are synchronized for a NAC when you use a Genesis Signal Master synchronization module and Genesis or Enhanced Integrity notification appliances. Separate NACs on the module are not synchronized.</p> <p>To silence audible appliances separately, use two NAC channels from the 3-IDC8/4 to provide separate audible and visible power to the NAC. In this configuration, the signal silence function operates as defined in your project. See Figure 5-1 for typical wiring.</p> <p>Configure the audible notification appliances for temporal or steady output as desired.</p>
3-SSDC(1)	<p>Signals are synchronized for all NACs on the Signature data circuit when you use SIGA-CC1S or SIGA-MCC1S modules and Genesis or Enhanced Integrity notification appliances. See Figure 5-3.</p> <p>The system does not synchronize Signature data circuits on separate 3-SSDC(1) modules in one panel or between panels.</p> <p>Signals are synchronized for a NAC on the Signature data circuit when you use SIGA-CC1 and SIGA-MCC1 addressable NAC modules, a Genesis Signal Master synchronization module, and Genesis or Enhanced Integrity notification appliances. [1] Separate NACs on the Signature data circuit are not synchronized. See Figure 5-4.</p> <p>Configure the audible notification appliances for temporal or steady output as desired.</p>
3-SDDC(1)	Synchronization is not supported between two daughter cards on the same 3-SDDC(1) module. NACs on the individual daughter cards are synchronized as described above for the 3-SSDC(1).

Table 5-2: Installation requirements for UL 864 signal synchronization

Circuit	Installation requirements
SIGA-CC1, SIGA-MCC1, SIGA-CC1S, and SIGA-MCC1S	Signature CC1 modules do not generate temporal signals, they simply turn the NAC circuit on or off. You must configure the notification appliances for temporal or steady output as desired.
G1M and G1M-RM	<p>The G1M and G1M-RM Genesis Signal Master modules can be used to synchronize NACs consisting of Genesis appliances.</p> <p>They can also be used to synchronize mixed NACs consisting of Genesis and Enhanced Integrity appliances, but the first appliance must be a Genesis device, and the Genesis Signal Master module must be mounted on this device.</p> <p>G1M and G1M-RM Genesis Signal Master modules cannot be used to synchronize NACs consisting of Enhanced Integrity appliances.</p>
<p>[1] You can also use SIGA-UM and SIGA-MAB modules configured as Class B addressable NAC modules (personality code 16.)</p> <ol style="list-style-type: none"> 2. If notification appliances are used on the data line for more than one zone, each zone must have isolation so that a break, ground, or wire-to-wire fault shall not affect more than one zone. 3. If the riser is used for more than one notification zone, install in accordance with the survivability from attack by fire requirements in NFPA 72 <i>National Fire Alarm Code</i>. 	

Typical circuits

The circuit diagrams that follow use the term *zone* to indicate *notification zones* as defined in UL 864.

“Notification zone: An area covered by notification appliances that are activated simultaneously.”

Figure 5-1 shows a typical application of the 3-IDC8/4 module to support two notification zones. In this example, power is being supplied from the EST3 rail, and the jumpers (JP1 through JP4) are set accordingly.

It is also possible to create a similar application that uses external power, supplied to NAC 1/2 IN and NAC 5/6 IN. Refer to the 3-IDC8/4 installation sheet for wiring details and the required jumper settings.

In Figure 5-1, both zones are configured with separate NAC circuits for audible and visible appliances. NAC 1 and NAC 5 are programmed as visible device types, and NAC 2 and NAC 6 as audible device types. This means that the signal silence function can be configured to silence only the horns.

Separating the visible and audible devices is optional and may not be required for your project. Refer to the Genesis Signal Master installation sheet for additional configurations and wiring details.

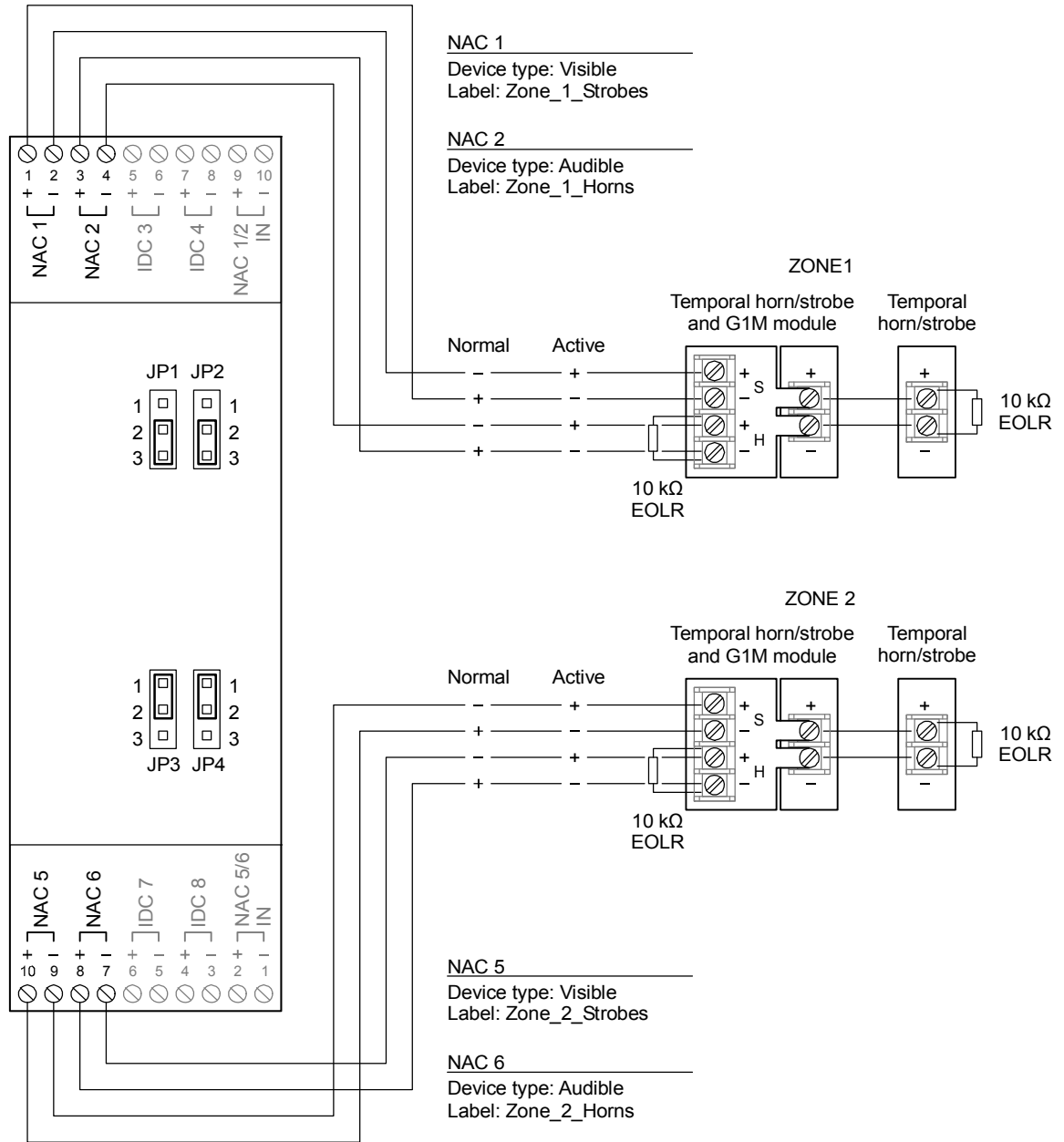

Figure 5-1: Typical 3-IDC8/4 card NAC wiring

Figure 5-2 shows a Signature circuit, wired as Class A, and using isolation modules or bases for each IDC and NAC.

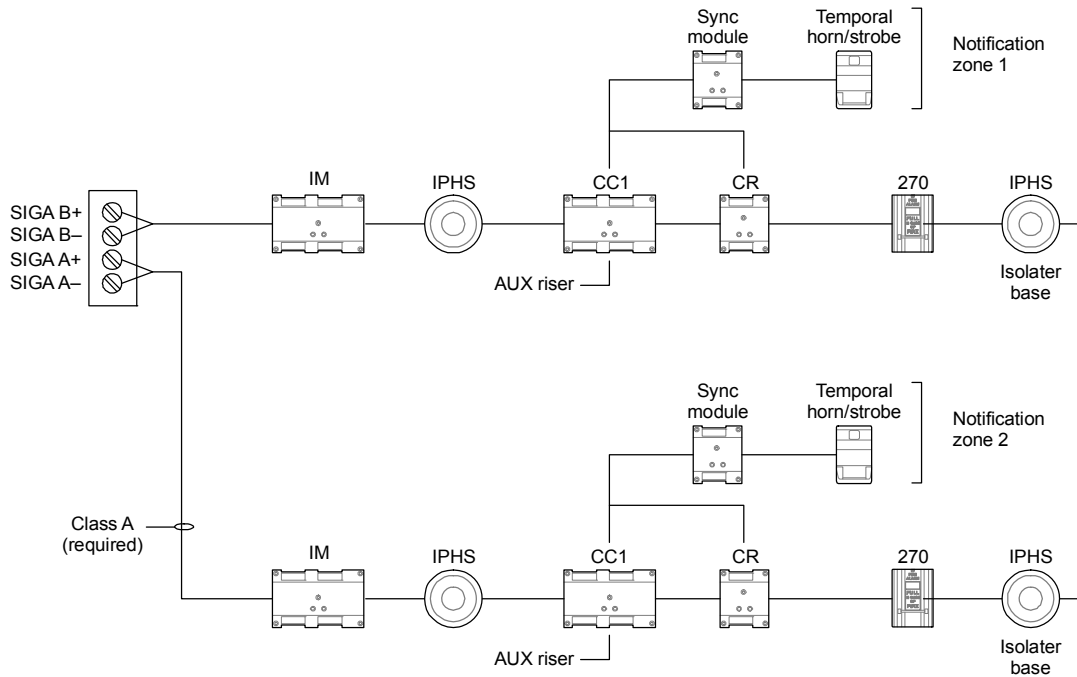

Figure 5-2: Signature wiring for notification circuit signal synchronization

Figure 5-3 Shows two NACs on a Signature data circuit. Each NAC is controlled by a SIGA-CC1S module, one for audible appliances, and one for visible appliances.

As in Figure 5-1, this configuration allows the audible appliances to be silenced independently of the visible appliances. This operation is optional, and may or may not be required for your project.

The SIGA-CC1S modules provide signal synchronization for both NACs.

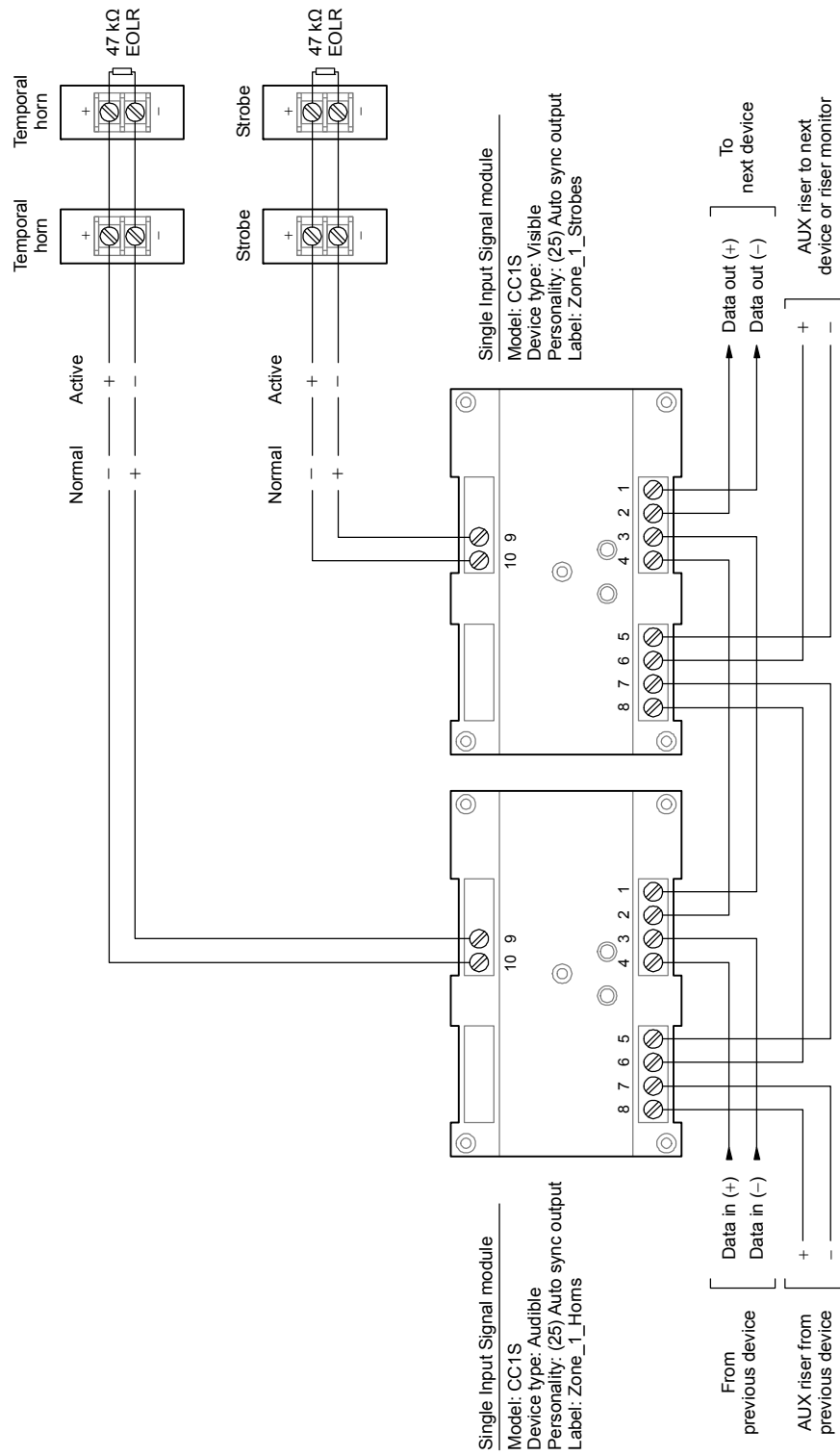

Figure 5-3: Typical SIGA-CC1S NAC wiring

Figure 5-4 shows a single SIGA-CC1 switching an NAC on or off. The G1M module provides signal synchronization for the temporal horn/strobe appliances.

As in earlier examples, this circuit allows for independent silencing of the audible appliances. This operation is provided by the SIGA-CR module, which opens or closes the circuit between S+ and H+ on the G1M module. In this case, however, you must program the operation of the SIGA-CR. The project settings for signal silence operation will not determine the operation of the audible appliances in this NAC.

Note also, that this application could be implemented with a SIGA-CC1S module. The SIGA-CC1S provides signal synchronization compatible with the operation of the G1M module.

The advantage to using a SIGA-CC1S module is that the NAC would then be synchronized with other NACs on the Signature data circuit.

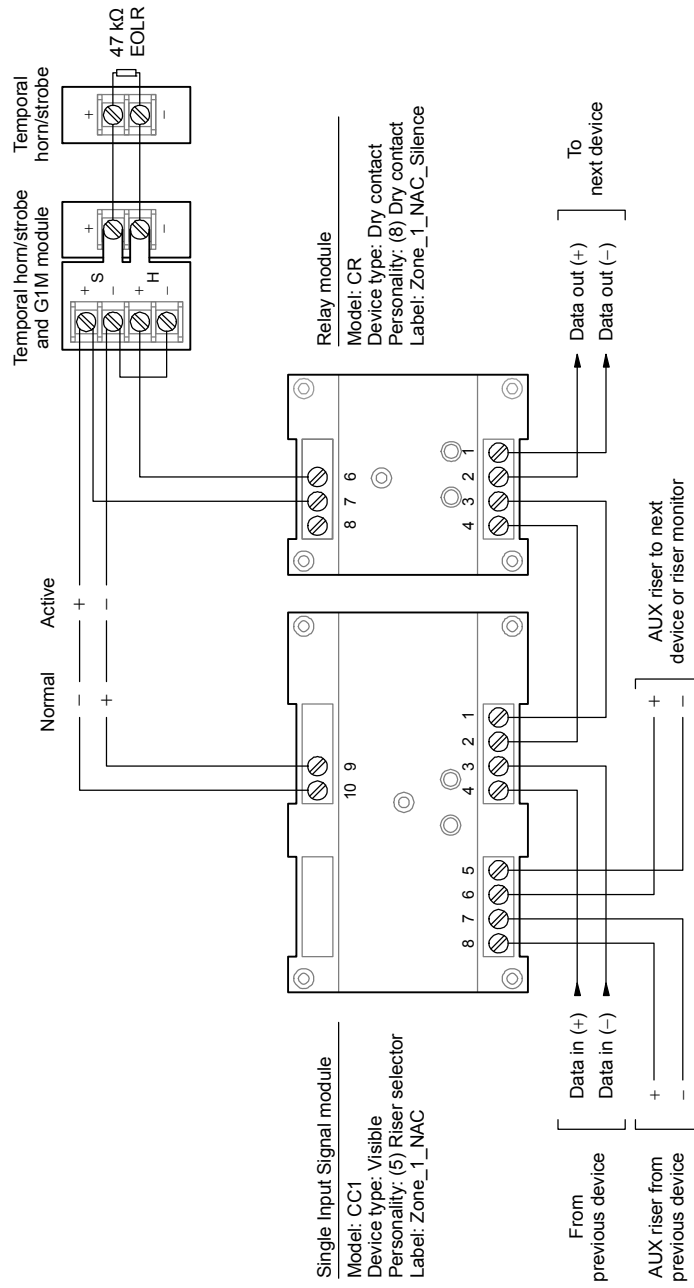

Figure 5-4: Typical SIGA-CC1 NAC wiring

Figure 5-5 shows an auxiliary/booster power supply being used to power the NAC, to provide synchronization, and to provide horn silence capability. Because the auxiliary/booster supply has the ability to silence the horn circuit, this application can be created using only the Signature loop wiring.

The SIGA-CT1 module monitors the power supply for AC failure. The SIGA-CR module signals the power supply to turn the horns on or off. The SIGA-CC1 module signals the power supply when the system goes into alarm, turning the NAC on.

Note that the power supply can only synchronize the notification appliances to which it is connected. If you need to synchronize several similar NACs on the same Signature loop, you can use a SIGA-CC1S module in place of the SIGA-CC1.

Notes

1. All wiring is supervised and power-limited unless otherwise noted
- [2] Install a PAM-1 or equivalent listed relay only when you are required to supervise the 200 mA AUX circuit wiring
- [3] Use part number EOL-47
- [4] Configure Sense 1 and Sense 2 operation for Genesis Master mode and NAC operation for Continuous. See the auxiliary/booster supply documentation for details.
- [5] Use a CC1S if you want to maintain signal synchronization across multiple auxiliary/booster supplies on the same Signature loop.

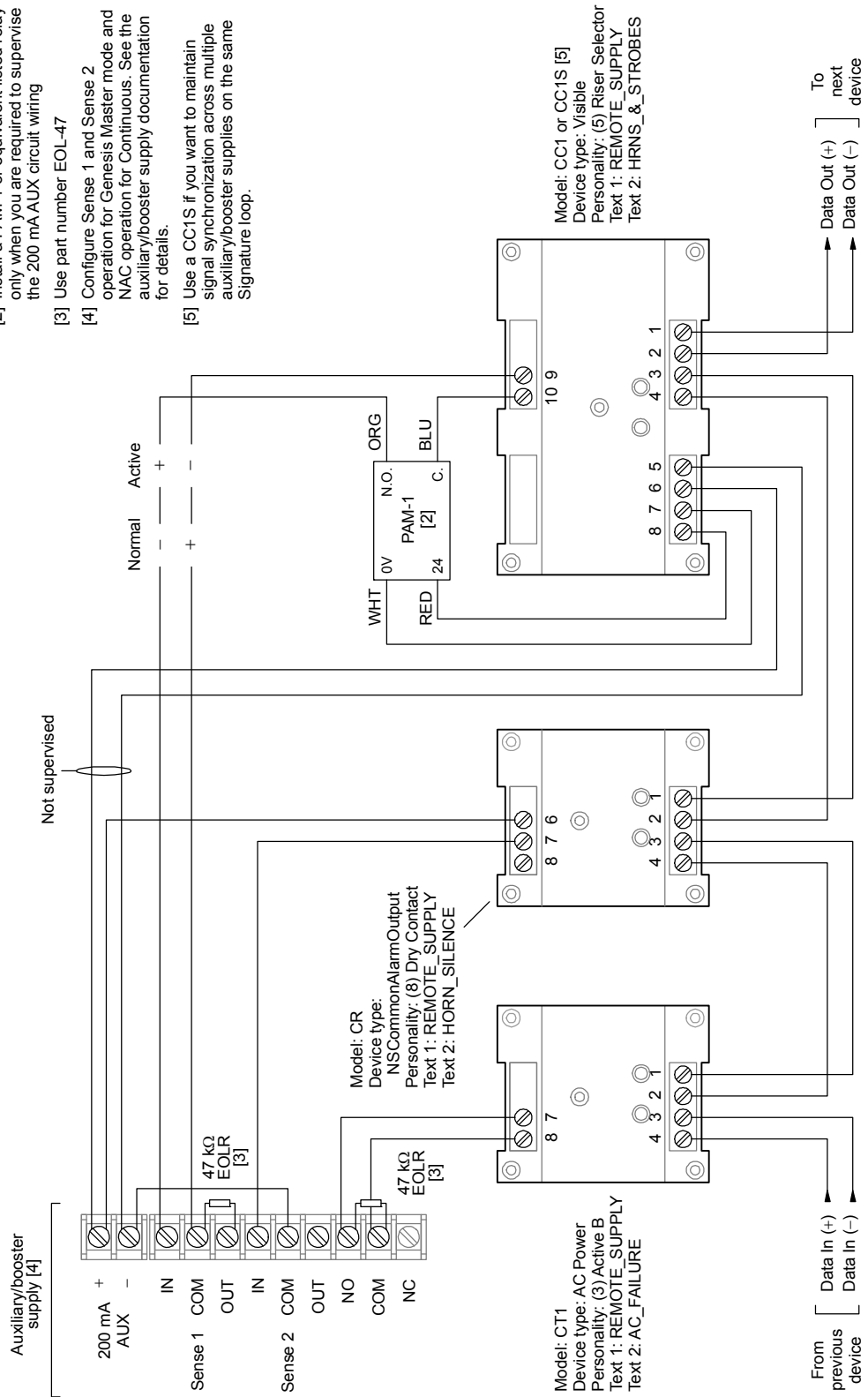

Figure 5-5: Using an auxiliary/booster supply to provide horn silence capability with two wires

Creating an initial startup version of the project database

Creating an initial startup version of the project database is useful for:

- Assigning panel addresses when you bring up a system for the first time
- Verifying the correct installation of the rail modules and control/display modules
- Adjusting the gain on the 3-ASU and amplifier modules installed in a cabinet

Follow these suggestions when creating an initial startup version of the project database:

Only include the hardware configuration for each cabinet in the system. Do not include any device loops in the database. These should be installed after verifying the cabinet configuration. It is also not necessary to configure any rail modules.

The easiest way to create an initial startup version of the project database is to save the project under a different name using the Save As command. Save the project as a different version after you have defined the cabinet chassis configuration and added all the rail modules for all the cabinets in the system. Using this method eliminates doubling your workload by having to edit two databases as you add cabinets to the system.

If the cabinet contains amplifiers and a 3-ASU, include the following features in the initial startup version of the project database:

- Program a control/display module toggle switch to send a 0.7 Vrms, 1 kHz tone to the amplifiers. Label the switch 1KHZ_TONE and add the following rule to the rules file:

```
[AMPLIFIER_SETUP]
SW '1KHZ_TONE':
    AMPON '*' TO 'Ch_Gen*',
    MSGON '1KHZ_TONE' TO 'Ch_Gen*';
```
- Record a message in the 3-ASU database labeled 1KHZ_TONE. Import the *Steady tone at 1kHz.wav* file from the EST3 Fire Alarm Support Tools CD-ROM into this record.

Note: For firmware versions earlier than 1.5, copy the *Steady tone at 1kHz.wav* file from the \Library\Sounds\FCCA directory on the EST3 Fire Alarm Support Tools CD-ROM to a directory on your hard drive that doesn't contain any other files. You can import the file from this directory.

If a CDR-3 Zone Coder is installed and connected to the AUX input on a 3-ASU, include the following features in the initial startup version of the project database:

- Program a control/display module toggle switch that is to turn on the amplifiers and select the Auxiliary channel. Label the switch AUX_INPUT_ADJUST and add the following rule to the rules file:

```
[3-ASU_AUX_INPUT_SETUP]
SW 'AUX_INPUT_ADJ':
    AMPON '*' TO 'Ch_Aux*';
```

System installation sequence

Follow these general instructions when installing a panel as part of an EST3 system. Refer to the installation sheets that came with the product for specific instructions. The *EST3 Installation Sheets* book contains copies of the installation sheets.

1. Install the equipment enclosure backbox at the required location and pull all the required conductors through the conduit into the backbox.
2. Verify the field wiring. Refer to Table 5-3.
3. Install the chassis assemblies that go into the panel.
4. Install the primary and booster power supplies.
5. Install all rail modules and control / display modules in their required locations.
6. Apply power to the panel. Refer to the topic “Cabinet power-up procedure” in Chapter 6.
7. Download an initial startup version of the CPU database, and clear panel troubles. See the topic “Creating an initial startup version of the project database,” later in this chapter.
8. Connect field wiring and clear any field wiring problems.
9. Download the final applications program. Refer to Chapter 6, “Power-up and testing.”
10. Disconnect the SDU from the panel.
11. Verify proper operation. Refer to the topic “Detector, input module, and output module testing” in Chapter 6.
12. Fill out a Certificate of Completion for the system. Example forms are included in Chapter 5.

Preliminary field wiring testing

We recommend that you test all circuits before they are connected to the control equipment. Table 5-3 indicates the recommended tests and acceptable test results.

Note: Individual devices are not checked as part of these tests. All equipment installed on field circuits must be individually tested to ensure proper operation when the system running.

Table 5-3: Field wiring tests

Circuit type	Test
DC notification appliance circuit	<ol style="list-style-type: none"> 1. Measure the resistance between conductors. The circuit resistance should be infinite if no devices are installed on the circuit. The circuit resistance should be approximately 15 kΩ when the polarized notification appliances and the end-of-line resistor are correctly installed. 2. Reverse the meter leads. The circuit resistance between conductors should read approximately 10 Ω to 20 Ω. If the resistance reading is still approximately the same value when the meter leads are reversed, one or more polarized devices are installed incorrectly. 3. Measure the resistance between each conductor and earth ground. The resistance should be infinite.
Audio notification appliance circuit	<ol style="list-style-type: none"> 1. Measure the resistance between conductors. The circuit resistance between conductors should be infinite if no devices are installed on the circuit. The circuit resistance should be approximately 15 kΩ when the polarized notification appliances and the end-of-line resistor are correctly installed. 2. Reverse the meter leads. The circuit resistance between conductors should still read approximately 15 kΩ. 3. Measure the resistance between each conductor and earth ground. The circuit resistance between a conductors and earth ground should be infinite.
Signature data circuits	<ol style="list-style-type: none"> 1. With field wiring disconnected, verify the continuity of each conductor. Each conductor should measure less than 38 Ω. 2. Measure the resistance between conductors. The circuit resistance between conductors should be infinite if no devices are connected to the circuit. The circuit resistance between conductors should be between approximately 18 kΩ (250 devices) and 4.5 MΩ (1 device) when devices are installed. 3. Measure the resistance between each conductor and earth ground. The circuit resistance between a conductors and earth ground should be infinite.

Table 5-3: Field wiring tests

Circuit type	Test
Addressable analog circuits	<ol style="list-style-type: none"> 1. Verify the continuity of each conductor. Each conductor should measure less than 50 Ω. 2. Measure the resistance between conductors. The circuit resistance between conductors should be infinite if no devices are connected to the circuit. 3. Measure the resistance between each conductor and earth ground. The circuit resistance between a conductors and earth ground should be infinite.
Traditional initiating device circuits	<ol style="list-style-type: none"> 1. Verify the continuity of each conductor. 2. Measure the resistance between conductors. The circuit resistance between conductors should be infinite if no devices are connected to the circuit. The circuit resistance between conductors should be approximately 4.7 kΩ when devices are installed. 3. Measure the resistance between each conductor and earth ground. The circuit resistance between a conductors and earth ground should be infinite.
Telephone riser circuit	<ol style="list-style-type: none"> 1. Verify the continuity of each conductor. Each conductor should measure between 0 and 25 Ω. 2. Measure the resistance between conductors. The circuit resistance between conductors should be infinite if no devices are installed on the circuit. The circuit resistance between conductors should be approximately 15 kΩ with SIGA-CC1 Single Input Signal Modules and the end-of-line resistor correctly installed. 3. Measure the resistance between each conductor and earth ground. The circuit resistance between a conductors and earth ground should be infinite.
RS-485 communication circuits	<p>EST3 uses RS485 circuits for the:</p> <ul style="list-style-type: none"> • Network data riser • Network audio riser • SAC bus <ol style="list-style-type: none"> 1. Verify the continuity of each conductor. Each conductor should measure between 0 and 50 Ω. 2. Measure the resistance between conductors. The circuit resistance between conductors should be infinite if no devices are connected to the circuit. The circuit resistance between conductors should be approximately 50 Ω when devices are installed. 3. Measure the resistance between each conductor and earth ground. The circuit resistance between a conductors and earth ground should be infinite.

Table 5-3: Field wiring tests

Circuit type	Test
RS-232 Communication Circuits	With both ends of the circuit disconnected: <ol style="list-style-type: none">1. Verify the continuity of each conductor. Each conductor should measure between 0 and 25 Ω.2. Measure the resistance between conductors. The circuit resistance between conductors should be infinite.3. Measure the resistance between each conductor and earth ground. The circuit resistance between a conductors and earth ground should be infinite.
Earth Ground	<ol style="list-style-type: none">1. Measure the resistance between the earth ground terminal and a convenient water pipe or electrical conduit. The circuit resistance should be less than 0.1Ω

Chassis installation in EIA 19-inch racks

Each 3-CHAS7 chassis or 3-ASU(/FT) Audio Source Unit requires 12 inches (30.48 cm) of vertical rack space. 3/4 inch (1.9 cm) blank plates are required at the top of the upper chassis and the bottom of the lower chassis. A 1-1/2 inch (3.81 cm) blank plate is required between each chassis.

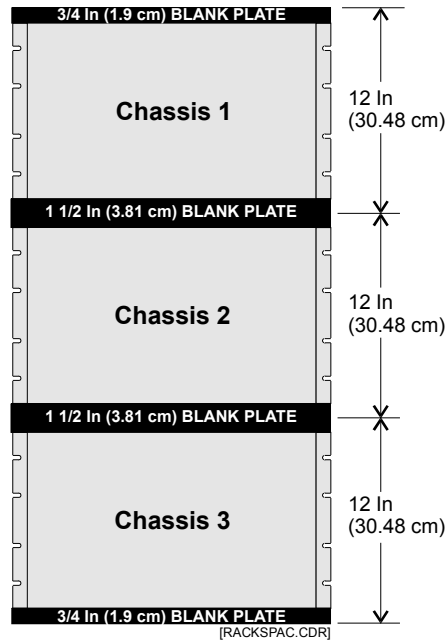

Figure 5-6: Rack-mounted chassis

ATCK Attack Kit for cabinets

EST3 supports several UL1635 certification installations. Each of these requires that an ATCK Attack Kit be attached to an RCC7R series control panel cabinet. The kit provides a two-minute attack delay time.

The ATCK kit lets you replace the standard, hinged outer door with a box cover that has no window. The cover attaches to the backbox sides using sheet metal screws and four locks.

The kit also includes special knockout locks that secure the unused knockout holes.

Follow the instructions shipped with the kit. In general, you'll need to:

1. Discard the standard door included with the cabinet.
2. For older cabinets, use the ATCK cover as a template to mark and drill screw holes. (New cabinets include the correct screw holes.)
3. Remove any unused knockouts and insert knockout locks.
4. Use the screws provided to attach the new cover.

Local rail module installation

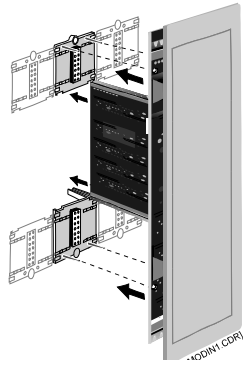

Please refer to the installation sheet that came with the product for installation instructions.

Equipment locations within a chassis are referred to as rail slots. Figure 5-7 indicates the rail slot numbers for the various cabinet sizes available in the EST3 product line. The CPU module must always occupy rail slots 1 and 2. The primary power supply monitor module should occupy rail slot 3.

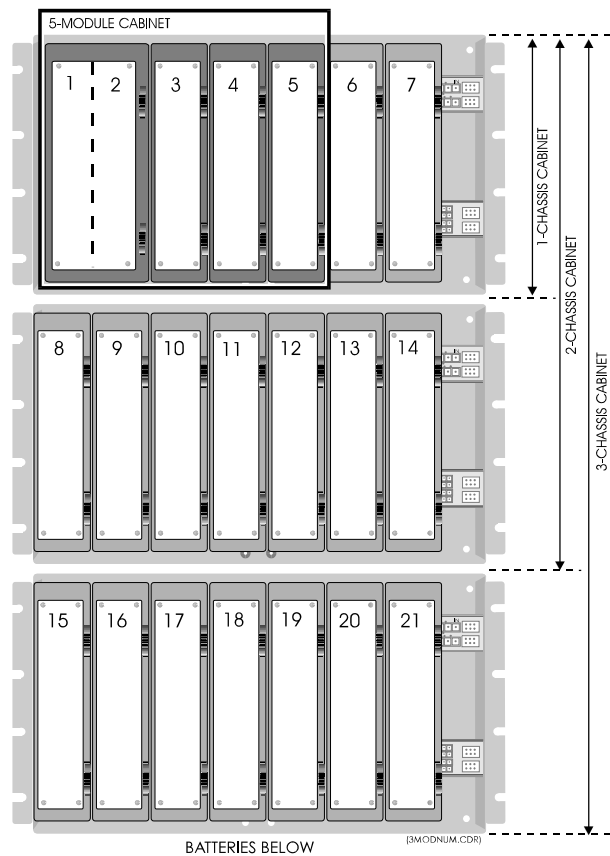

Figure 5-7: Local rail module slot identification

A 3-ASU Audio Source Unit occupies the first three slots on its chassis, and is identified using the lowest slot number of the three. When a Firefighters Telephone Control Unit is supplied as part of the 3-ASU/FT, the telephone control unit occupies the last four slots on the chassis, and is identified as the fourth slot number (11 or 18) on the chassis.

Connect the DC power cable (P/N 250187) to connector P2 on the power supply. For the 3-PPS Primary Power Supply, connect the 16-pin data ribbon cable (P/N 250188); (Booster = P/N 250189) to connector P3 on the power supply. For 3-BPS

Booster Power Supplies, connect a 14-pin data ribbon cable (P/N 250189) to connector P3 on the power supply. Route both cables up through the rails for later connection to the power supply/booster monitor module.

- Install any local rail module option cards required by your application. Option cards should be firmly seated in their connectors, and then secured to the rail module by pressing the snap rivet fastener.
- If a control/display module is required by your application, place the display in the recess on the front of the module. Secure the display with the four supplied plastic rivets. Install the display ribbon cable (P/N 250186) between the display's connector and the module's display connector. If no display is required, insert the blank plate supplied with the module.
- Locate the required rail slot positions on the rail chassis. Remember, the module location must match the location entered in the System Definition Utility program.
- Position the module so that any option card(s) rests in the card guides slot. Push the module toward the rails, sliding the daughter card into the slot.
- When the four alignment pins match up with the guide holes in the module, push the module in to firmly seat the module on the rail connectors.
- Push in the snap rivets to lock the module on to the rail.
- Plug in terminal strips can be removed from LRMs to facilitate field wiring.
- Close the module display door. Latch the door by sliding the upper latch down and the lower latch up.

Note: If there are empty rail spaces in a cabinet, you should consider installing 3-LRMF blank modules to fill up the spaces.

3-MODCOM Modem Communicator module

Features

The 3-MODCOM Modem Communicator is a local rail module that supports telephone line communication. It combines the functions of a dialer and modem in a single module.

The module has two eight-position modular jacks for connecting to telephone lines. It includes two red LEDs (DS1 and DS2) to annunciate line ringing and data exchange. The module accepts a control / display layer and has provision for a future expansion module.

A nonvolatile, flash memory chip stores customization data that includes account information, user identifiers, telephone numbers, and other dialing details.

The 3-MODCOMP is identical to the 3-MODCOM, but supports remote paging using the Telocator Alphanumeric Protocol (TAP). The 3-MODCOMP remote paging feature is supplemental and is not supervised.

Both versions of the module are equipped with a modem that is Bell 103 and V.32bis compliant. The modem includes support for these protocols:

- Contact ID
- SIA DCS
- SIA P2 (3/1 pulse format)
- SIA P3 (4/2 pulse format)
- TAP (3-MODCOMP only)

Several 3-MODCOMs (up to ten) can be installed in a network for increased reliability. These can be configured to provide dynamic failover operation.

You can program the 3-MODCOM in any of the following configurations:

- One-line dialer
- Two-line dialer
- Modem
- Modem and one-line dialer
- Modem and two-line dialer

The dialer circuit is compatible with pulse dialing or touch-tone (DTMF) dialing. The module can be configured to detect and answer any of these ring types:

- Any ring
- Normal ring
- Distinct ring 2 (type II)
- Distinct ring 3 (type III)

Note: Only Line 1 can be used to receive incoming calls.

Using the 3-MODCOM, messages can be sent to a central monitoring station (CMS) or received from remote computers.

When reporting to a CMS, alarm, trouble, and supervisory status data are transmitted as they occur. Each message identifies the point (or device or circuit) that is involved.

The 3-MODCOM can receive data from two programs: the Access Control Database program (ACDB) or the Keypad Display Configuration program (KDC).

ACDB and KDC information is downloaded on demand from remote computers. This lets the end users create and maintain their own security and access control databases.

Functions

Configuration

You create the required configuration data using the 3-SDU and download this data to the module using standard programming procedures. The data is stored in the nonvolatile memory of the 3-MODCOM.

Configuration data determines the setup of the 3-MODCOM, defines the line properties, the receiver attributes, and the account parameters. This data includes transmission details, such as telephone numbers and dialing options.

Some reference data relating to user access control and security systems is downloaded from the ACDB or KDC programs and stored in the 3-MODCOM.

Point transmission

Using enhanced communication protocols, the 3-MODCOM module is capable of transmitting data that identifies the specific device (or circuit) and event status, as reported by the CPU. This capability is known as point transmission because each and every device (or circuit) that goes into alarm or trouble, or is restored, can be reported by order of occurrence and priority.

Receiving user data

In addition to transmitting device data, the 3-MODCOM module can receive user data from remote computers. In this mode, the module receives access control or security database information from one or more end users. This data establishes the operating characteristics of the user's security and access control system as well as the various access options and PIN numbers. All downloaded data is received over the telephone lines.

The remote programs, ACDB and KDC, use passwords defined during 3-SDU programming to gain access to the 3-MODCOM.

At the start of the downloading process, a connection is established between the modem portion of the 3-MODCOM module and the ACDB or KDC program. Connection is over the telephone network.

The 3-MODCOM module receives data and transfers it to the CPU. The data is then routed via the 3-SAC to the CRC and KPDISP modules on the SAC bus. The data is stored in the nonvolatile flash memory chips of these devices.

Monitoring and diagnostics

Each line has a voltage monitor for detecting loss of telephone line during on-hook condition, and a current monitor for detecting the loss of telephone line and telephone line usage during off-hook conditions. Optical coupler circuits are used for these monitors.

Two red LEDs (DS1 and DS2) annunciate line ringing, in use, and fault conditions. States and explanations for DS1 and DS2 are given in the “Service and troubleshooting” chapter.

Equipment

3-MODCOM – Modem Communicator

The 3-MODCOM connects the EST3 system to the switched telephone network. The 3-MODCOM module is a single rail module with two eight-position modular jacks for connecting two loop-start lines. The 3-MODCOM module provides a control / display layer and space for a future expansion insert card.

The 3-MODCOM can support 255 accounts. It can communicate with 80 receivers in any of the following protocols:

- Contact ID
- SIA DCS
- SIA P2 (3/1 Pulse Format)
- SIA P3 (4/2 Pulse Format)

The 3-MODCOM is supplied with two seven-foot cables (P/N 360137). These are eight-conductor, flat telephone cables, with eight-position modular plugs on both ends. One end of the cable plugs into the 3-MODCOM. The other end plugs into an RJ-31X jack.

You must obtain the RJ-31X jack locally, and wire it to the telephone lines as indicated on the 3-MODCOM installation sheet.

3-MODCOMP – Modem Communicator with Paging

The 3-MODCOMP is identical to the 3-MODCOM except for the inclusion of the TAP paging protocol. The end user must subscribe to a TAP-compatible alphanumeric paging service.

Depending on the paging service provider, the TAP message can be broadcast via radio to a pager, converted to an e-mail, or faxed to an end user.

The module is supplied with two seven-foot cables (P/N 360137) for connecting the 3-MODCOMP to an RJ-31 jack. You must obtain the RJ-31X jack locally, and wire it to the telephone lines as indicated on the 3-MODCOM installation sheet.

RJ-31X jack – telephone company jack

An RJ-31X jack must be used to connect each line of the 3-MODCOM to the switched telephone network. One jack is required for each telephone line.

The jack is an eight-position jack with a special jumper between terminals 1 and 4 and 5 and 8. This jumper is in effect when the plug is removed from the jack.

Removing the plug re-establishes connection to the premises telephones. Inserting the plug opens the jumper and connects the 3-MODCOM, which provides a series connection to the telephones.

Refer to the 3-MODCOM installation sheet for a diagram of the jack wiring.

Note: Failure to use an RJ-31X jack violates FCC and NFPA regulations. A telephone connected directly to the incoming telephone line without the proper use of the RJ-31X jack will cause a telephone company trouble when used and possibly prevent the dialer from getting through to the CMS receiver in an emergency.

Configuration options

3-MODCOM and 3-MODCOMP can be configured as:

- One-line dialer
- Two-line dialer
- Modem
- Modem and one-line dialer
- Modem and two-line dialer

For UL listed or FM approved installations, you must configure the 3-MODCOM as a two-line dialer, and both lines must have supervision (line-cut detection) selected.

The 3-MODCOM operates in accordance with programmed instructions. Details of items such as telephone numbers, dialing

details, activation of a dialer test signal, etc., are all a part of the information that is downloaded into the nonvolatile memory of the 3-MODCOM by the SDU.

The 3-MODCOM electronically dials receivers in the central monitoring station (CMS) using either pulse or tone dialing, as specified during configuration. The module dials the stored CMS telephone number using the same digits that would be used if a person were dialing from the premises with an ordinary telephone.

Each time the 3-MODCOM sends test messages to the CMS, it indicates whether the system is in a normal or abnormal state. You can select which system states (such as *alarm*, *trouble*, or *monitor*) represent an abnormal condition. This prevents the 3-MODCOM from reporting an abnormal condition when the system is in a state that occurs frequently as part of normal system operation.

There are provisions for programming a periodic test transmission to the CMS station on a one-minute to 45-day basis. A daily test signal is primarily intended for certified installations, and is mandatory for all fire alarm installations.

The 3-MODCOM sends messages in order of their priority. Messages may include device and user ID information regarding events, such as openings, closings, alarms, and tamper or trouble events. The module waits for acknowledgement that each message sent has been received. Where necessary, the 3-MODCOM can be configured to begin dialing without waiting for a dial tone. This option is used in areas where the telephone line has an absent or erratic dial tone.

Failover operation

You can create dynamic failover operation for 3-MODCOMs. By *dynamic failover* we mean that in the event of a communication failure or device trouble, the system switches from accounts on one 3-MODCOM to matching accounts on another 3-MODCOM.

Failover operation results in a system that is resistant to trouble arising from telephone lines, 3-MODCOMs, or the CPU module. The operation can be limited to a single panel, or can span two or more panels anywhere in a network.

In systems with a single 3-MODCOM you can include a second 3-MODCOM that acts as a redundant unit. In systems with two or more 3-MODCOMs, you can program the system so that the units back up each other, while still handling their normal traffic.

Failover operates by enabling and disabling various accounts defined for the project. On detection of a fault or trouble, project

rules disable accounts on the failed 3-MODCOM and enable matching accounts on the backup 3-MODCOM.

When a 3-MODCOM acts as a backup it still provides line supervision. Only the backup *accounts* are disabled. Further, backup units should conduct their own dialer tests, using unique accounts that identify the 3-MODCOM. Even when not in use, a backup unit should generate a trouble event if it cannot contact the assigned receiver.

Because of the way rules are processed, when the primary 3-MODCOM comes out of trouble, the accounts are automatically switched back to their normal state. Messages already queued for transmission in the backup unit will still be sent, even after backup accounts are disabled. Only new messages will be routed differently. This means that device activation and restoral messages sent to the CMS will still be properly paired.

Failover operation is created by specific configuration and programming steps. These are outlined below.

Configuration requirements

- For each primary 3-MODCOM add (or select) a backup 3-MODCOM in the same panel or in a different panel according to the scope of failover operation you need
- Configure the primary and backup 3-MODCOMs identically except for their labels and the labels of the accounts
- Label the accounts so that it's easy to recognize the 3-MODCOM in which they are used
- Make sure each 3-MODCOM uses a unique account for dialer tests

Programming requirements

- Create message rules that send identical messages to both accounts
- On system startup, disable the accounts on the backup 3-MODCOM
- On activation of a panel comm fault, line fault, or LRM comm fault, disable the primary accounts and enable the backup accounts

ACDB requirements

Additional steps are required when the project includes reporting to a CMS that requires translation from a Cardholder ID to a cardholder name. In this situation, the ACDB user must enter a User ID (name) for both CMS Accounts (the primary and backup accounts).

These entries are made on the System tab of the Cardholder tab. The ACDB user should enter a User ID for each CMS Account.

Compatibility

EST3 versions

The 3-MODCOM Module will operate with EST3 Version. 3.0 or above. Do not use this communication module with earlier versions.

Receiver compatibility

Refer to the *EST3 ULI/ULC Compatibility Lists* (P/N 3100427), for a list of compatible receivers.

Transmission protocols

The 3-MODCOM is capable of transmitting messages in five formats, or protocols:

- Contact ID
- SIA DCS
- SIA P2 (3/1 Pulse Format)
- SIA P3 (4/2 Pulse Format)
- TAP (3-MODCOMP only)

All formats consist of short, predefined messages. Most contain several parameters, some of which are optional. Check with your dialer receiver and central monitoring station software provider for the exact structure they require.

When programming transmissions, remember that device messages require two separate send commands, one for activation, and one for restoration.

Contact ID: numeric messages with several parameters including event code, partition, and device or user. The format is:

[EventCode] [Partition] [DeviceNumber | User]

SIA DCS: ASCII text messages that include a number of optional parameters, including time, date, user, partition, and device. The format is:

[Date] [Time] [UserID] AlarmCode [Device | User | Partition]

SIA P2 (3/1): numeric messages that consist of four digits. These contain the account number (three digits) and the alarm code (one digit). The format is:

AccountNumber AlarmCode

There is no standard assignment of alarm codes and meanings. Obtain the codes used by your CMS.

SIA P3 (4/2): numeric messages that contain two numbers and no other parameters. The format is:

EventCode

TAP: consists of two fields separated by a carriage return (CR). The first field is the User ID. The second field is the text message that will be displayed on an alphanumeric pager. Message length, including User ID and CR is 60 characters. The format is:

User [CR] Message [Location]

No standards describe the content of the message. Typically, you'll use the device location message, as displayed on the LCD module. Check with your paging service provider to ensure they accept the TAP protocol and determine any message limitations.

Transmission process

The 3-MODCOM includes features that provide an appreciable level of transmission integrity. Multiple telephone lines and multiple telephone numbers help to ensure that a call to the receiver gets through. The 3-MODCOM module sequences through the following basic steps to contact the central monitoring station receiver.

1. The 3-MODCOM seizes one of the telephone lines and puts the line on-hook for a minimum of three seconds.

This cuts off any ongoing call and disconnects the line from any telephone or dialing devices that are connected downstream.

Note: The module tries to select an unused line for its first two attempts.

2. The 3-MODCOM takes the line off-hook and waits for a dial tone.

LED DS1 or DS2 lights steadily.

If a dial tone is not received by the configured time, the module goes on-hook, increments the attempt counter, and continues to alternate lines and numbers until a dial tone is acquired.

If the 3-MODCOM is configured with two telephone numbers and only one telephone line, it will make four attempts using the first telephone number, then four attempts using the second telephone number. This alternation of telephone numbers continues as needed until a connection is made or the configured number of dial attempts have been made.

Note: In areas where the telephone system has no dial tone, or where the dial tone is erratic, you can set the 3-MODCOM to dial without waiting for a dial tone. This is called *blind call dialing*

3. The 3-MODCOM dials the CMS using the programmed dialing mode and telephone number.
4. The 3-MODCOM waits for a handshake message from the CMS indicating that a connection has been established.

If a handshake is not received within 40 seconds the module puts the telephone line on-hook and waits for the configured period.

After the wait, steps 2 through 4 are repeated. If the module is still unable to contact the receiver it seizes the other telephone line.

The module repeats two attempts on the other telephone line. If still unable to contact the receiver it switches back to the first telephone line and attempts to contact the receiver using the secondary telephone number.

If still unable to contact the receiver the module continues to alternate lines and numbers until the configured maximum number of attempts have been reached.

If the maximum number of attempts is reached, the module sends a trouble message to the CPU.

The 3-MODCOM retries the full number of attempts if another event is activated or make one attempt if a configured period (Wait Time Between Attempts) expires.

5. When the call is completed, ringing is detected by the CMS dialer-receiver (DACR). The DACR goes off-hook and transmits a handshake.
6. If the handshake matches the desired transmit format, the 3-MODCOM transmits, in the specified format, all premises event data.

LED DS1 or DS2 flashes rapidly to indicate data is being transmitted.

7. The 3-MODCOM waits for an acknowledgement and a shutdown signal from the CMS receiver, then puts the line on-hook, ending the call.

LED DS1 or DS2 extinguishes.

Programming considerations

Accounts and receivers

In addition to the general operating characteristics of the 3-MODCOM, you'll need to specify each account and receiver used by the system. You may want to gather this information before you begin using the SDU.

A *receiver* is a destination for a 3-MODCOM call to a CMS. Typically, a CMS will have many receivers in operation, each capable of receiving multiple calls. The CMS will determine which receiver you should use for each account. For configuration purposes, here's what you'll need to specify about the receiver:

- Label
- Description
- Primary telephone number
- Secondary telephone number
- Protocol to use
- Maximum number of dial attempts
- Wait time between dial attempts

An *account* links a specific end user to a specific receiver. Each message sent from the 3-MODCOM includes an account number assigned by the CMS. This identifies the user site sending the message and the receiver to which the message is sent. For each account you'll need to define:

- Label
- Description
- Receiver to use
- Account number (as assigned by the CMS)
- Dialing test interval and time of day

Several accounts may use the same receiver, but each account is assigned to only one receiver.

Events and commands

One event and two commands are particularly important when you create SDU rules for the 3-MODCOM. These are: activation, activate, and send.

Security and access control devices do not send event messages to the CPU. Rather, they send requests to execute predefined command lists. You need to define the command lists and assign the correct command list for each security or access control event.

Activation: an event that lets you define a command list.

Activate: a command that lets you execute a command list in a rule.

Send: a command that sends a message to a CMS through the 3-MODCOM.

Installation

Caution: Prior to installation, remove power from the rail.

To install the 3-MODCOM, you'll need to follow these general steps:

1. Arrange suitable telephone company lines and services.
2. Install the 3-MODCOM on the rail.
3. Connect the 3-MODCOM to the telephone company lines.
4. Download configuration data from the 3-SDU.
5. Make test transmissions to verify proper operation.

Requirements for telephone lines

3-MODCOM dialers can be used for most applications that use telephone lines, the exceptions being:

- The central station telephone number cannot be dialed directly (using access numbers and area code where necessary) without operator interception of the call
- Multiparty service (a party line) exists
- Operator assistance is required to complete a telephone call and a foreign exchange cannot be introduced
- Connection is not established within 38 seconds following completion of dialing

The 3-MODCOM dialer circuit is compatible with any switched telephone network that employs direct dialing (local) and Direct Distance Dialing (DDD), without operator interception of the call.

Operator interception occurs in some areas where message billing is not completely automatic. Where operator interception is involved, you must obtain a foreign exchange (FX) connection must from the central station exchange to the exchange serving the customer. The FX provides a local number for calling the central station without toll billing. A WATS or ground-start line connection must not be used for this purpose because the line cannot be supervised.

The 3-MODCOM includes a feature that prevents jamming by an incoming telephone call. The feature is based on a telephone service option referred to as *called party disconnect*. This option lets the receiver of a call disconnect by hanging up the telephone

for a period of time, even if the caller stays on the line. The time required for disconnect varies in different areas, but is usually between 18 and 90 seconds. Called party disconnect is available in most areas. To determine whether called party disconnect control is available in the area to be served, consult the local telephone company.

In areas not having called party disconnect, the 3-MODCOM module is vulnerable to jamming by an incoming call. To minimize the possibility of jamming, we recommend that the customer order a separate, unlisted number for exclusive use of the 3-MODCOM module. The customer should keep this number confidential. In the case of the two-line dialer, two premises telephone numbers would have to be busied by incoming calls to jam the system.

Progressive anti-jamming measures would entail the use of one unlisted telephone number, or two unlisted numbers for maximum dialer integrity.

The 3-MODCOM must be connected to the incoming line *ahead* of all connected equipment on that line, but just behind the demarcation block. This puts the control unit telephone connection in series, assuring that all telephones, answering machines, and FAX machines are disconnected during dial-out to the CMS. This requirement is necessary so the 3-MODCOM dialer circuit can seize the line for its exclusive use in the event of an alarm.

Do not use a telephone line that is considered essential for conducting business at the site. Use a separate line for the 3-MODCOM. The dialer must be the first connection in line, and it seizes the line and disconnects all other equipment when making a call.

If the incoming lines to the protected premises involve a rotary telephone line arrangement, make the connection to the line having the highest number. This will create the least interference with business lines.

Note: If connection will be made to a telephone company line that is also used for normal business purposes, advise customer that the telephone service will be disrupted for a few minutes during the connection period.

In areas where the telephone company requires that their own connector block be installed, it should be wired as per the USOC RJ-31X or RJ-38X configuration. (The RJ-38X configuration is identical to RJ-31X except for a jumper between 2 and 7 which is used in some residential applications but is not used by the 3-MODCOM.)

When the 3-MODCOM is configured as a two-line dialer module, two incoming lines must be used and connections must be made to each line.

Installing the 3-MODCOM module

Make sure that panel power is off, then proceed as follows,

1. Use an antistatic wrist strap to ground yourself to an unpainted part of the cabinet.
2. Carefully remove the 3-MODCOM from the antistatic bag in which the module is packed. Always handle it by the edges or by the plastic door.
3. Place the bag on a flat work surface, then place the module, connector side up, on the empty bag.

Check for shipping damage. Orient the module so the two eight-position modular telephone jacks are on the top.

4. If a control / display module is needed, remove the blank front plate and attach the ribbon cable to the front of the 3-MODCOM board.
5. Refer to the SDU cabinet report to determine the proper location for the module, then plug the module into the rail.
Be careful to align the module and rail sockets so that the pins are in the proper holes and that seat the module firmly.
6. Fasten the module in place with the push-pins.
7. Restore power to the panel.
8. Install wiring to module as described on the 3-MODCOM installation sheet.

Connecting the 3-MODCOM to a telephone line

Plug one end of the supplied telephone connecting cord (P/N 3601370) into the telephone company line jack on the 3-MODCOM.

Do not plug the other end into the RJ-31X jack until you are ready to test the system. This prevents unnecessary interference with other equipment connect to the line downstream.

When you are ready for final connections and testing, use the telephone company line jacks as follows:

Line 1 jack	Line 2 jack
Single-line dialer	Second line of 2-line dialer
Incoming modem line	

For the installation of a fire alarm system in compliance with NFPA 72, the 3-MODCOM must be connected to loop-start

telephone lines. If the site has ground-start lines, two separate loop-start lines must be installed for the dialer.

To determine the type of telephone company line, disconnect the line pair and connect the lines to a test meter.

If the line is equipped for loop-start, the meter should read 48 to 52 Vdc between the lines.

If the line is equipped for ground-start, the meter will read 0 Vdc between the lines, 48 to 52 Vdc between one line and ground, and 0 Vdc between the other line and ground.

Note: AT&T Horizon PBX systems and some Type 75 systems are of the loop-start type. AT&T Dimension PBX systems and other Type 75 systems are equipped for ground-start.

If this installation is for a certified fire alarm system or a burglar alarm system in compliance with NFPA 72, the telephone company line must be of the *called party disconnect* type (also called timed-release disconnect). This feature permits the communication module to seize the line and dial out, even when the telephone company line is in use.

To determine the whether the telephone line supports called party disconnect

1. Have someone telephone the premises from the outside.
2. Hang up the telephone that received the call, but have the individual who placed the call remain on the line.
3. After 40 seconds, pick up the called telephone again.
 - If you are no longer connected to the caller
 - If the caller is still on the line

Loading configuration data

After installing the 3-MODCOM, use the SDU network downloading process to load the configuration data for the 3-MODCOM.

The SDU provides a report that lists all CMS codes that can be transmitted from the 3-MODCOM. Give this report to the appropriate CMS.

Testing transmission

After the CMS has programmed the central monitoring database, perform transmission tests as required by the AHJ and CMS.

Note: Transmission failures are latched at the panel. This means that you must reset the panel in order to clear them.

3-SAC Security Access Control module

Product description

The 3-SAC is a high-speed RS-485 module used to support Card Reader Controller modules and Keypad Display modules. Events are passed to the 3-SAC module, then passed to the CPU for alarm processing.

The 3-SAC has two sets of circuit terminals, and is capable of Class A or Class B configuration. Each Class B circuit can handle 31 devices, for a total of 62 devices per module. Class A circuits can handle 30 devices total.

SAC bus

The 3-SAC Security Access Control module supports the SAC bus, an RS-485 communication line. When properly constructed, the SAC bus runs over longer distances, supports more drops, and is more immune to noise than an RS-232 line.

The SAC bus consists of two lines:

- SAC bus +
- SAC bus –

Recommended cabling

Since our security and access control devices require 24 Vdc, we suggest that you always use a four-wire cable for the SAC bus and a 24 Vdc power supply.

For the data wires we suggest unshielded, twisted pair, with greater than 6 twists per foot, in 14 to 22 AWG (1.50 to 0.25 sq mm).

For the power wires, we recommend 14 or 16 AWG.

Additional power supply wiring

When an additional power supply is required, you must connect a circuit common point for correct operation. To establish a circuit common, connect the –24 Vdc terminal on the additional power supply to the –24 Vdc terminal of the last device. This circuit common must be connected to the panel, to every device, and to the circuit common point of any additional power supplies.

3-AADC1 Addressable Analog Driver Controller and IRC-3

When upgrading an IRC-3 system to EST3, the 3-AADC1 Addressable Analog Driver Controller module lets you use existing IRC-3 system segments without rework.

The 3-AADC1 can be connected to an existing IRC-3 Remote Zone Interface Module (RZB(V/N)12-6/3) or a Universal Input Output Module (UIO-12).

The 3-AADC1 Addressable Analog Driver Controller module provides one Class A or Class B loop. This loop becomes the data communication line for the existing IRC-3 system.

The 3-AADC1 includes a line interface module (LIM) card. You can also use the LIM card from an existing 3-AADC module by installing it on a 3-AADC1-MB. The MB version is a local rail module without a LIM card.

The audio features of the EST3 system can be connected to the audio riser channels of the RZB module, or existing audio equipment can be left in place.

Similarly, the EST3 system power supplies can provide 24 Vdc power to the RZB or UIO cards, or existing power supplies can be left in place.

Refer to the following installation sheets for wiring details:

- *3-AADC1 and 3-AADC1-MB Addressable Analog Driver Controller Installation Sheet*
- *RZB(V/N)12-6/3 Remote Zone Interface Module Installation Sheet*
- *UIO-12 Universal Input Output Module Installation Sheet*

AC power and DC battery wiring

Due to power-limited/nonpower-limited wiring separation requirements, it is easier to route and wire the nonpower-limited AC power and battery conductors before installing the LRMs in the rails. Nonpower-limited wiring should be routed to the chassis notches to the left and rear of the cabinet. Power-limited wiring should be routed to the right and front of the cabinet.

WARNING: Do not energize power until instructed to do so!

1. Connect the AC power source to TB1, line, neutral, and ground terminals on the 3-PPS/M Primary Power Supply Heat Sink and the 3-BPS/M Booster Power Supply Heat Sink(s). **DO NOT ENERGIZE THE AC POWER SOURCE AT THIS TIME!**
2. Connect the positive battery lead to TB2-1 and the negative battery lead to TB2-2. Each heat sink assembly must have its own pair of 12 AWG (2.5 sq mm) wires going to the battery. Do not connect the heat sinks assemblies together and run a common wire to the battery! **DO NOT TERMINATE THE WIRES AT THE BATTERY AT THIS TIME.**

WARNING: Do not connect batteries until instructed to do so!

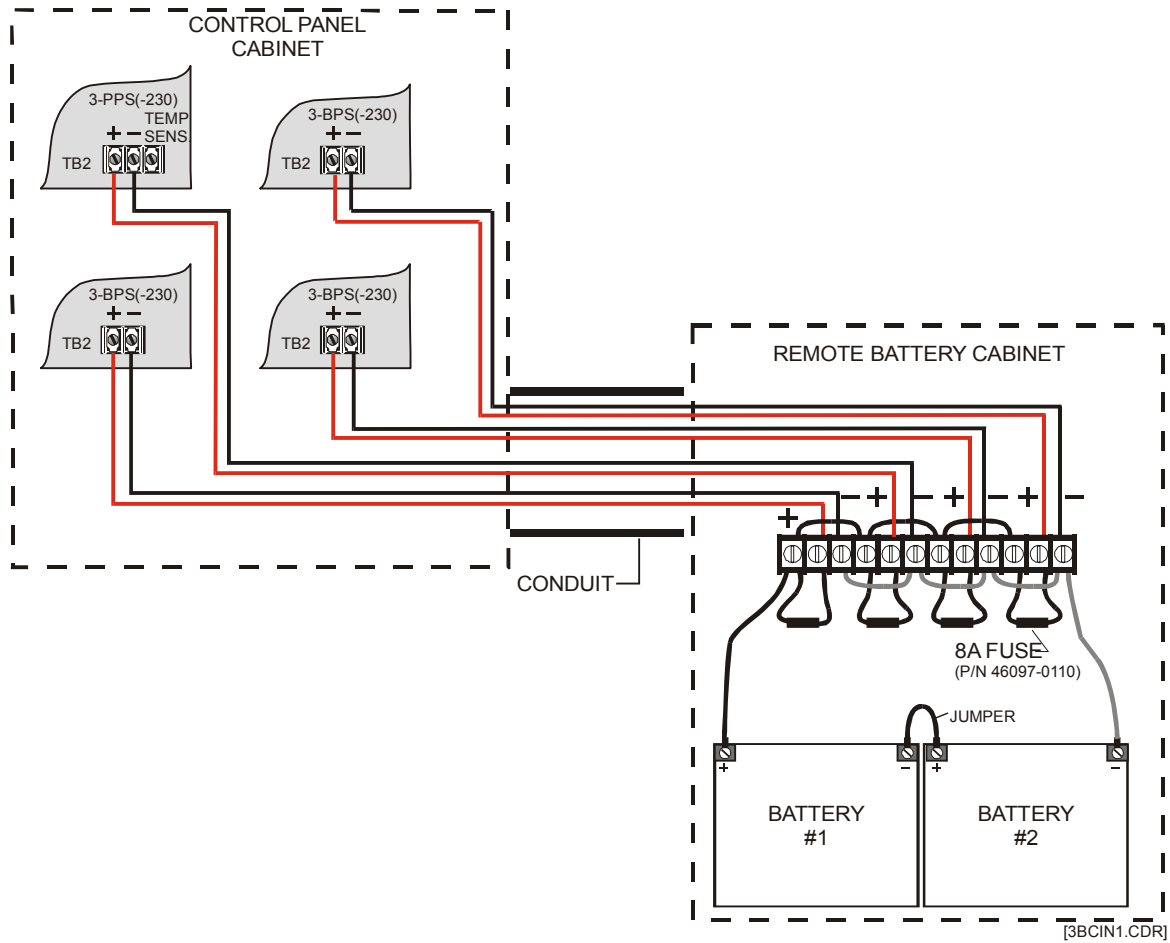

Figure 5-8: Remote battery cabinet wiring

Note: A minimum of a 10Ah battery must be used in all systems applications.

Connecting auxiliary/booster power supplies

UL requires that you monitor secondary power sources for loss of AC power. Upon loss of AC power, the control panel must provide an audible and visible trouble signal. In addition, remote station, central station, and proprietary-type protected premises units must transmit a trouble signal off-premises after a one- to three-hour delay.

To meet UL requirements you need to connect a SIGA-CC1 (or SIGA-CC1S) and a SIGA-CT1 to the booster supply. The SIGA-CC1 is used to activate the booster supply and to signal common troubles. The SIGA-CT1 is used to signal booster supply AC power failures.

Installation

Mount the SIGA-CC1 and SIGA-CT1 inside the booster supply as described in the booster supply's technical documentation and wire them as shown in Figure 32.

Configuration

Booster supply

Set SW2-6 to ON. This configures the booster supply's Trouble relay to close only on loss of AC power. All other booster troubles are signaled through the sense circuits.

Note: In Figure 32, the booster supply is configured so that Sense 1 controls all four NACs. For DIP switch settings for this and other booster supply configurations, refer to the booster supply's technical reference manual.

Signature modules

Configure the Signature modules as described below.

Module	Properties
SIGA-CC1	Model = CC1 Device Type = CommonAlarmOutput Personality = (5) Riser Selector Text 1 = REMOTE_SUPPLY Text 2 = SENSE_1
SIGA-CT1	Model = CT1 Device Type = ACFail Personality = (3) Active B Text 1 = REMOTE_SUPPLY Text 2 = AC_FAILURE

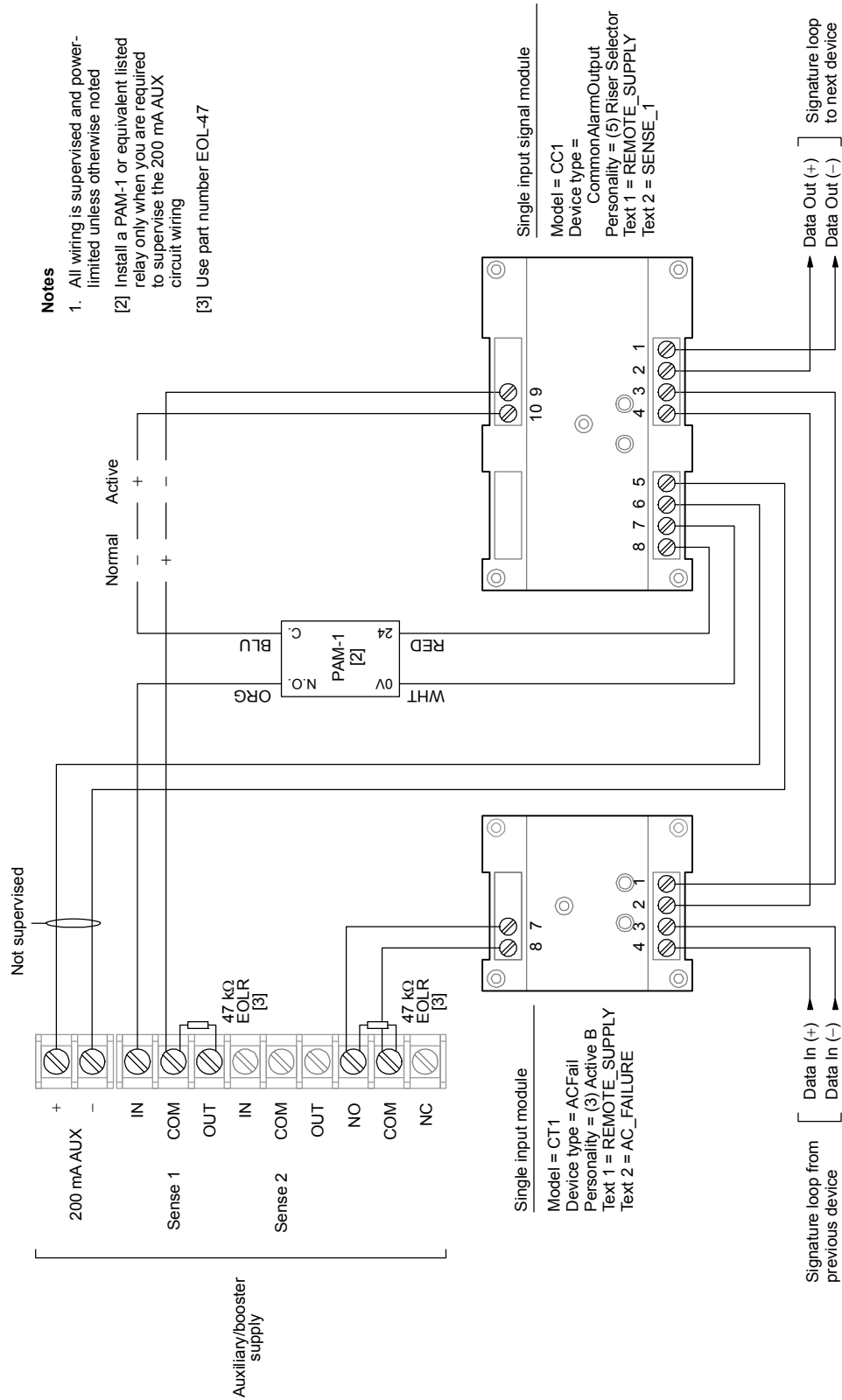
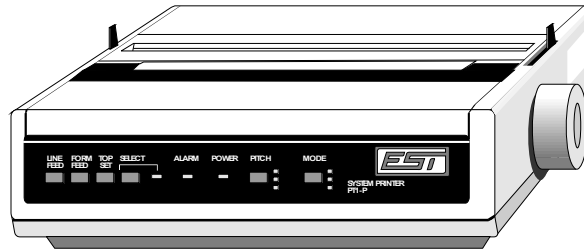

Figure 5-9: Typical booster power supply wiring

Connecting the PT-1S impact printer

The PT-1S impact printer can be connected to an EST3 panel to provide a hard copy printout of system status, active events, panel reports, etc. The PT-1S is a 80-character line width, freestanding printer that uses standard form feed paper.



[CP11SKCDF]

When connecting the PT-1S impact printer by itself:

- Configure the serial port as a Printer port type and set the baud rate for the printer's baud rate.
- Set printer switches SW1-1, -2, and -3 to OFF, ON, and ON, respectively (8 bits, no parity).

When connecting the PT-1S impact printer to a serial port that is shared with a CDR-3 Zone Coder:

- Use an IOP3A to connect both devices. Refer to the topic "Connecting a CDR-3 Zone Coder for coded tone output" later in this chapter.
- Configure the panel's serial port as a CDR-3/Printer port type and set the baud rate for the CDR-3's baud rate.
- Set printer switches SW1-1, -2, and -3 to OFF, OFF, and ON, respectively (8 bits, even parity). These are the factory settings.
- Set printer switches SW2-1, -2, and -3 to match the baud rate set on the CDR-3 zone coder.

PT-1S Printer Specifications

Dimensions (HWD)	3.2 in x 14.2 in x 10.8 in (8.13 cm x 36 cm x 27.4 cm)
Print Speed	232 Characters/Second
Baud Rates	110, 300, 600, 1200, 2400, 4800, 9600, 19200 bps.
Wiring	3 #18 AWG (0.75 mm ²)
Voltage	120 Vac @ 60 Hz
Standby Power	40 VA

Printing Power	120 VA
----------------	--------

Switch DIPSW factory settings (located on main board)

SW1	SW2	SW3	SW4	SW5	SW6	SW7	SW8
OFF (English)	OFF (English)	OFF (English)	OFF (11-in form)	ON (11-in form)	OFF (auto LF off)	ON (8 bits)	OFF (enable front panel)

Switch SW1 factory settings (located on serial board)

Switch	Factory Setting	Description
SW1-1	OFF	ON: Odd parity OFF: Even parity
SW1-2	OFF	ON: No parity OFF: With parity
SW1-3	ON	ON: 8 bits OFF: 7 bits
SW1-4	OFF	ON: Ready/Busy protocol OFF: XON/XOFF protocol
SW1-5	ON	ON: Circuit test OFF: Monitor test
SW1-6	ON	ON: Print mode OFF: Test mode
SW1-7, -8	ON,ON	OFF,OFF: SSD Busy OFF,ON: SSD Busy ON,OFF: RTS Busy ON,ON: DTR Busy

Switch SW2 factory settings (located on serial board)

Switch	Factory Setting	Description
SW2-1, -2, -3	OFF,OFF,ON	OFF,OFF,OFF: 110 bps ON,OFF,OFF: 300 bps OFF,ON,OFF: 600 bps ON,ON,OFF: 1200 bps OFF,OFF,ON: 2400 bps ON,OFF,ON: 4800 bps OFF,ON,ON: 9600 bps ON,ON,ON: 19200 bps
SW2-4	OFF	ON: DSR active OFF: DSR inactive

Switch SW2 factory settings (located on serial board)

Switch	Factory Setting	Description
SW2-5	ON	ON: 32-byte buffer threshold OFF: 256-byte buffer threshold
SW2-6	ON	ON: 200ms busy signal OFF: 1s busy signal
SW1-7	OFF	ON: Space after power on OFF: Space after printer select
SW1-8	OFF	not used

System printer power supply

If your PT-1S system printer is required to operate during a brownout or AC power failure, install an uninterruptible power supply per Figure 5-10.

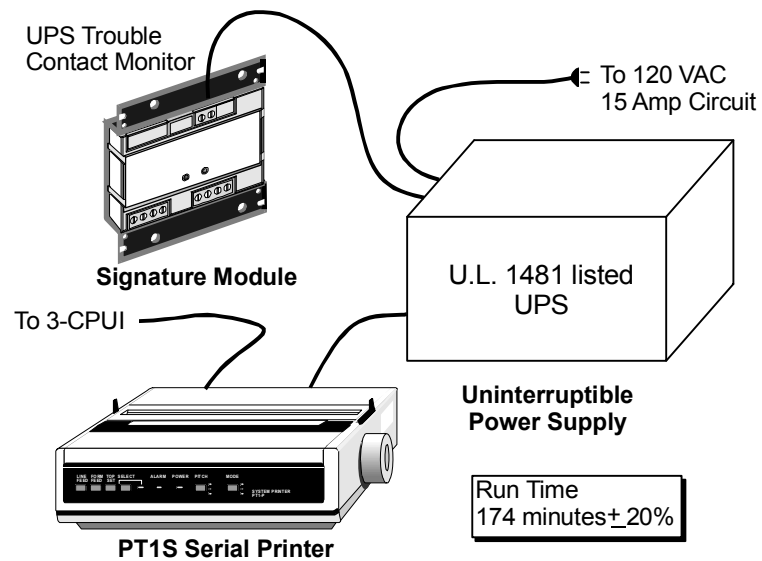

Figure 5-10: Printer uninterruptible power supply wiring

Adjusting amplifier output levels

What you will need

An initial startup version of the project database that contains a 1kHz tone and a switch programmed to turn the tone on. See “Creating an initial startup version of the project database.”

An RMS voltmeter (Fluke 83 or equivalent)

Adjustment procedure

1. Disconnect the field wiring to all the zoned amplifier modules in the cabinet.
2. Place an RMS meter across an amplifier’s TB2 NAC/B+ and NAC/B- terminals.
3. Use the 1KHZ_TONE switch to turn on the tone.
4. Adjust the amplifier’s gain pot until the RMS meter displays the configured output level (25 or 70 Vrms).
5. Connect the amplifier’s field wiring.
6. Use the 1KHZ_TONE switch again and verify that the output level remains the same. Readjust the amplifier’s gain pot if necessary.
7. Disconnect the amplifier’s field wiring.
8. Repeat steps 2 through 6 for each amplifier in the cabinet.
9. Reconnect the field wiring for all the amplifiers in the cabinet.

Design considerations

Your audio system will work best if the prerecorded tones and messages have roughly the same volume, or amplitude. The process of establishing a common maximum amplitude is sometimes called *normalizing*.

We suggest that you normalize your tones and messages to a maximum amplitude of 1 V peak-to-peak, or an average of 0.7 Vrms.

The SDU does not contain a tool for normalizing your audio clips, so you'll need to use a sound editor to normalize the clips before you import them into the SDU database.

The audio clips included in the EST3 Support Library CD have already been normalized.

Connecting a CDR-3 Zone Coder for coded tone output

The CDR-3 Zone coder can be connected to the 3-ASU's AUX input to provide a coded or march time tone to the audio system. Refer to Figure 5-11. If you're connecting a CDR-3 to a serial port that is shared with a PT-1S printer, you must connect both devices using an IOP3A, as shown in the wiring diagram in this topic.

What you will need

An initial startup version of the project database that contains a switch programmed to turn the amplifiers onto the Auxiliary channel. See "Creating an initial startup version of the project database."

An RMS voltmeter (Fluke 83 or equivalent)

Adjusting the gain on the 3-ASU auxiliary input

The 3-ASU auxiliary input gain adjustment is critical to the operation of this application. Before adjusting the 3-ASU, set each zoned amplifier module in the cabinet for their configured RMS output level. See "Adjusting amplifier output levels."

To adjust the gain on the 3-ASU auxiliary input

1. Connect the coded tone output on the CDR-3 directly to the 3-ASU auxiliary input by bypassing the duration relay.
2. Set the 3-ASU auxiliary input gain pot to the mid-range position.
3. Determine which zoned amplifier module requires the highest gain adjustment (the module whose gain adjustment pot is turned the most counter-clockwise). Use this amplifier as the worst-case amplifier.
4. Disconnect the field wiring from all the amplifiers in the cabinet except for the worst-case amplifier. This is to prevent the CDR-3's supervisory tone from being broadcast throughout the premises.
5. Place an RMS meter across the worst-case amplifier's TB2 NAC/B+ and NAC/B- terminals.
6. Press the AUX_INPUT_ADJ switch. This places the coder's supervisory tone onto the Auxiliary channel. The supervisory tone occurs approximately every 5 seconds.
7. Adjust the 3-ASU's auxiliary input gain pot until the RMS meter displays the amplifier's configured output level (22-28

Vrms or 65-75 Vrms). Turning the pot clockwise increases the gain while counter-clockwise decreases the gain.

8. Press the AUX_INPUT_ADJ switch a second time to restore the input.
9. Reconnect the coded tone output of the CDR-3 back through the duration relay.
10. Reconnect the field wiring to the remaining amplifier modules.

Installation

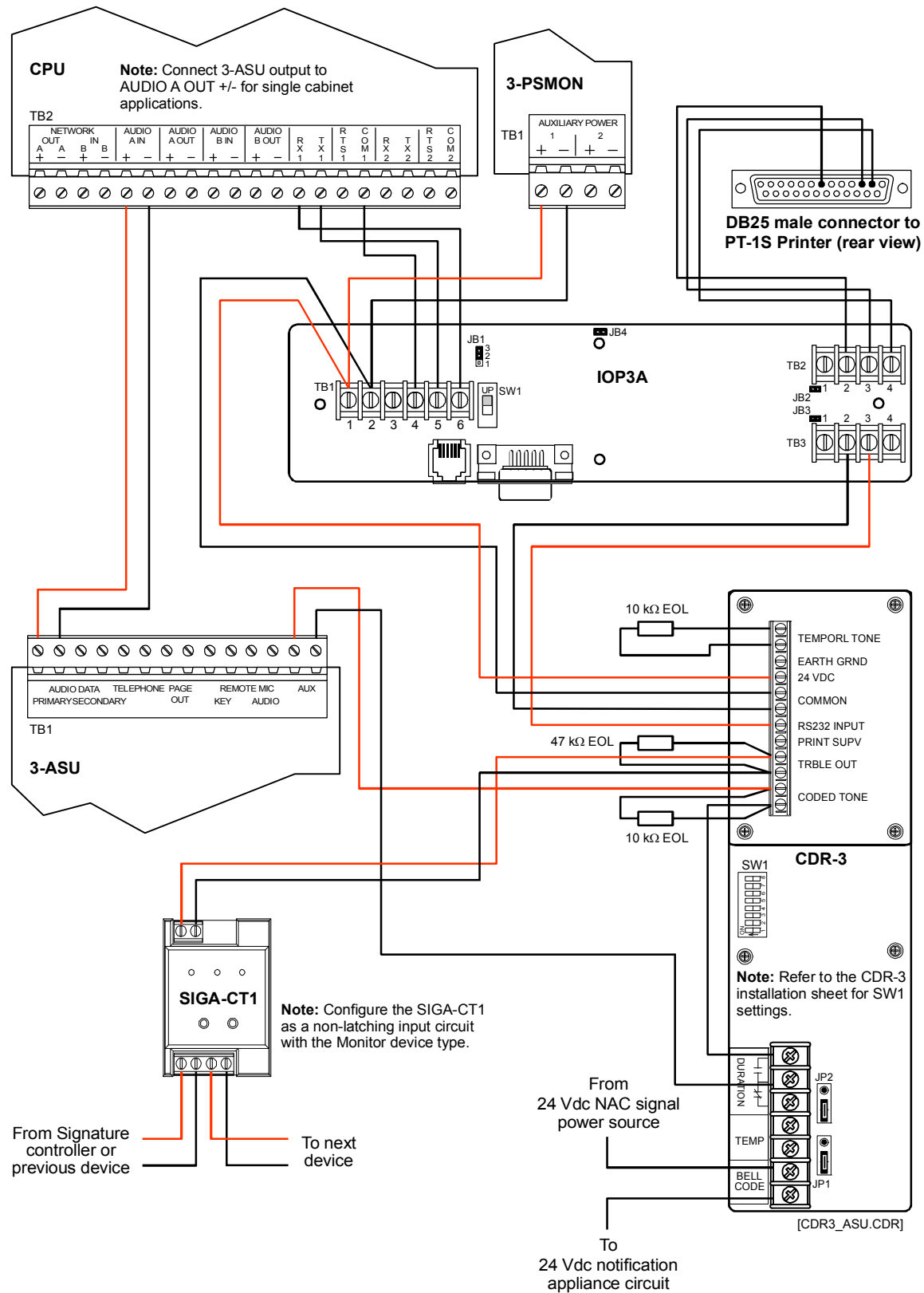

Figure 5-11: Application wiring diagram

Connecting an external modem for use with the Remote Diagnostics Utility

Using the Remote Diagnostics Utility requires that you connect an external modem to a CPU equipped with a 3-RS232 option card.

Some applications may require that the modem be permanently mounted. The following is a suggested method for mounting a modem connected to the CPU. First you will need to obtain the following parts

- MFCA accessory enclosure
- SIGA-MP1 mounting plate
- 2 cable ties long enough to go around the modem and through the slots on the SIGA-MP1

To mount the modem:

1. Mount the MFCA enclosure back box at an acceptable location within reach of the panel. Refer to Figure 5-12.
2. Secure the modem to the SIGA-MP1 with the 2 cable ties.
3. Screw the SIGA-MP1 to the MFCA enclosure back box.
4. Connect all modem wiring. Refer to the technical documentation that came with the modem for wiring connections.

RS-232 wiring must maintain a 1/4-in minimum separation between nonpower-limited wiring.

5. Screw the MFCA cover to the back box.
6. Attach the modem RS-232 wires to the CPU serial port terminals. The serial port must be configured for Remote Diagnostics in the project database. See below.

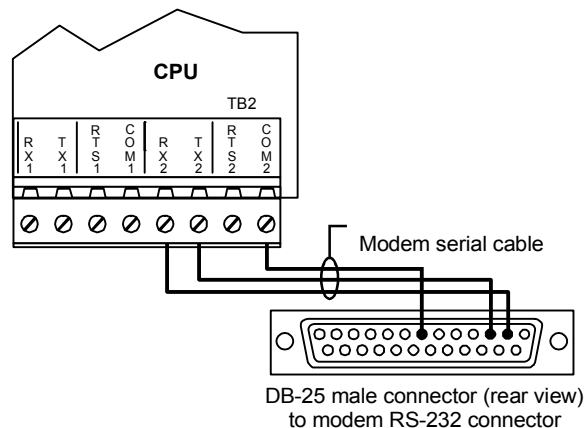

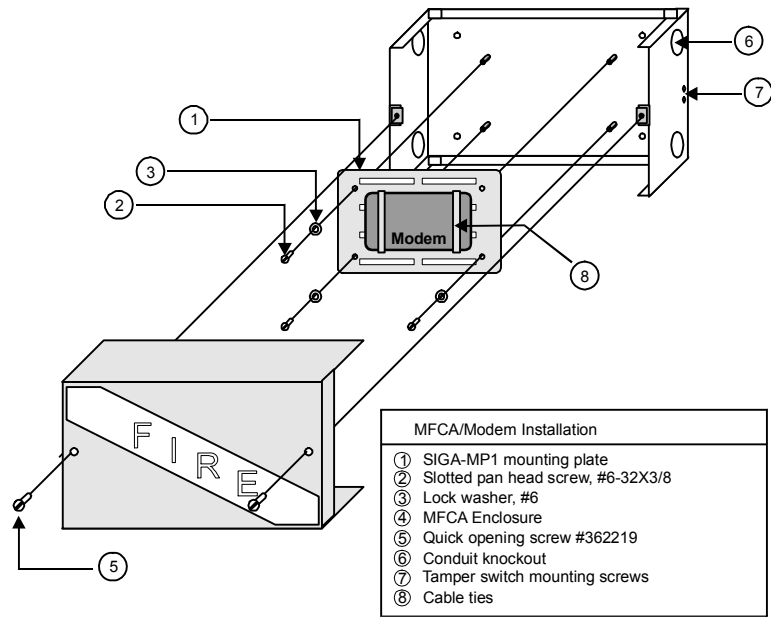

Figure 5-12: Suggested modem installation using MFCAs and SIGA-MP1

Running the RPM and distributing profiles

The Resource Profile Manager (RPM) is an add-on tool that works with the SDU. The RPM lets you:

- Create a description of the companies and buildings at a site
- Assign security and access control devices to companies and buildings
- Specify a primary company (owner) for each CRC
- Allocate device resources among companies that share the devices

This information is displayed in a two-pane window that includes a tree structure and a data table. The tree structure shows the organization of companies and buildings and the assignment of partitions and devices to the buildings. The data table shows the labels, properties, and allocation numbers for the current tree selection. You could think of this as the overall resource profile for the project.

The RPM lets you export resource profiles for individual companies. These are later imported into the Access Control Database (ACDB) and Keypad Display Configuration (KDC) programs.

Once imported, the profiles determine what the users see and control when creating their portions of the security or access control system.

To create and distribute resource profiles, you follow these general steps:

1. Enter company and installer contact information.
2. Create buildings and assign them to companies.
3. Assign partitions and devices to the buildings for each company.
4. Allocate device resources to each company.
5. Export a resource profile for each company.

The RPM includes a Mass Assign function to help you establish a uniform baseline allocation of resources. A Summary display is available so you can review and print the profile in several different forms.

When your project includes security or access control applications, run the RPM and distribute resource profile diskettes to the ACDB and KDC users.

Refer to the *SDU Online Help* for details on these steps. Refer to the *Card Reader Controller (CRC) Technical Reference Manual* for details on configuring CRCs.

Summary

This chapter provides information and procedures necessary to perform initial system power-up and acceptance testing.

Content

- Cabinet power-up procedure • 6.3
 - Initial power-up • 6.3
- Runtime and system errors • 6.4
 - Introduction • 6.4
 - Runtime errors • 6.4
 - System errors • 6.5
- Initial and reacceptance test procedures • 6.6
 - Introduction • 6.6
- Control and emergency communications equipment testing • 6.7
 - Primary power supplies • 6.7
 - Booster power supplies • 6.7
 - CPU with LCD module • 6.8
 - 3-RS232 card installed in CPU • 6.10
 - 3-RS485 card installed in CPU, Class B configuration • 6.10
 - 3-RS485 card installed in CPU, Class A configuration • 6.11
 - 3-IDC8/4 Initiating Device Circuit module • 6.11
 - 3-SSDC(1) Signature Driver Controller module • 6.11
 - 3-AADC(1) Addressable Analog Driver Controller module • 6.12
 - 3-OPS Off-premises Signaling module • 6.12
 - 3-ASU Audio Source Unit • 6.14
 - 3-FTCU Firefighter Telephone Unit • 6.14
 - 3-ZAxx Audio Amplifiers • 6.16
 - Control/display modules • 6.16
 - Amplifier transfer panel (ATP) • 6.17
- Detector, input module, and output module testing • 6.18
 - Signature Series detectors and bases on a 3-SSDC(1) module circuit • 6.18
 - Addressable analog detectors on a 3-AADC(1) Module circuit • 6.19
 - Traditional 2-wire smoke detectors connected to 3-IDC8/4 modules • 6.19
 - Conventional 2-wire smoke detectors connected to SIGA-UM modules • 6.19
 - Signature series input modules • 6.20
 - Signature series output modules • 6.20
- Initiating device testing • 6.21
 - Manual stations • 6.21
 - Nonrestorable heat detectors • 6.21
 - Restorable heat detectors • 6.21

Power-up and testing

- Waterflow switches • 6.21
- Notification appliance testing • 6.23
 - Visual devices • 6.23
 - Speakers • 6.23
 - Bells and horns • 6.23
- Record of completion • 6.24

Cabinet power-up procedure

Initial power-up

1. Energize AC power at 3-PPS/M (-230) Power Supply and the 3-BPS/M (-230) Booster Power Supplies.
2. Connect batteries to the 3-PPS/M (-230) Power Supply and the 3-BPS/M (-230) Booster Power Supplies.

While the CPU's microprocessor is initializing, the LCD displays status messages.

3. Connect the download cable assembly between the SDU computer and CPU connector J5.
4. Using the SDU, download the CPU database into the panel controller. Refer to the next topic, "Runtime and system errors," should error messages be displayed on the LCD module.
5. If an Audio Source Unit is part of the system, its database must be downloaded in addition to the CPU database. For best download performance, we suggest you connect directly to the 3-ASU/FT module and download its database in single-step mode.
6. Clear up any network communications faults between cabinets.
7. If any Signature controller modules are installed as part of the system, their individual databases must be downloaded in addition to the CPU database. You will need to restart the network for these changes to be effective.
8. Correct all the circuit faults.
9. Test the system as described in the next section.

Note: Remember that for a network system, you'll need to make the initial download to each CPU separately, to establish the correct cabinet numbers. After the initial download, all further downloads can be made from a single panel via the network.

Runtime and system errors

Introduction

There are two major categories of errors which can occur when configuring a database for the network. The System Definition Utility program is used to set up the contents of each cabinet. Once all the cabinets have been defined, devices labeled, and rules written, all this information is cross checked against itself. This process is called compiling the program. If there are incorrectly written rules, unreferenced input or output devices or other problems with the design, the compiler will generate a list of errors. These errors must be corrected using the SDU.

When the data has been properly compiled, the data is in a form that the CPU memory can receive. Sending this information to the memory of the various CPUs making up the network is called downloading. If an error occurs during the download process, it is referred to as a runtime error.

Runtime errors

There are a number of reasons that errors may occur when downloading data into the CPU controllers. Initially, certain “errors” are to be expected, as the network database is loaded in steps. Until all portions of the database are properly entered into memory, errors will be generated. During initial system configuration, this is to be expected. Most of these errors will resolve themselves as the system configuration progresses.

A second source of download errors is a mismatch between the cabinet configuration in the SDU and the actual hardware installation. The most common cause for this error is typically due to the installation of a local rail module in the wrong rail position. Another common cause is the installation of the wrong type module in the rail. Misidentification of an entire cabinet can also cause this type of error.

A third source of download error can occur after the cabinets have been initially downloaded. After the initial downloads, all subsequent downloads can be done using the network data circuit. The third type of error is primarily caused by communications problems between cabinets.

Table 6-1: Download errors

Error message	Possible cause
Unable to perform operation	General error. Restart CPU
Busy signal	System currently busy. Wait, then retry
Password Invalid	Incorrect or invalid password entered
Size parameter trouble	Check download connections and SDU settings, then retry
Storage media trouble	Problem with memory components. Swap module and retry.
Checksum error in packet	Check download connections and SDU settings, then retry
Device type error	Conflict between SDU download setting and connected device type
Parcel #	Check download connections and SDU settings, then retry
Inaccessible panel	SDU program can not “see” the panel. Check network wiring
Session in progress	System is busy. Wait, then retry
Write protect	Write protect switch on 3-ASUMX is on
Erase program trouble	Check download connections and SDU settings, then retry
Block number	Check download connections and SDU settings, then retry
Version mismatch	Firmware downloaded does not agree with version setting

Note: If you are experiencing frequent problems downloading to a 3-CPU, low signal levels from the SDU computer may be the cause. The Buffered RS-232 Communications Cable, P/N SDU-CBL, may be used to correct signal level problems. Do not use this cable with the CPU.

System errors

The CPU does not send data to the SDU program. Except for problems with the communications between the CPU and the PC running the SDU program, the majority of problems with the runtime process are annunciated on the LCD module’s display. Refer to Chapter 5, “Service and Troubleshooting” for system error codes and their possible causes.

Initial and reacceptance test procedures

Introduction

Once the system has been wired, programmed, and the circuit faults corrected, all installed components should be tested *as a system*, to insure proper operation.

The initial system check is designed to verify that all components of the system are installed and operating as designed. Verifying that the system was designed and installed according to specifications requires all aspects of the system to be exercised and the results verified. Where test results differ from those expected, corrective action must be taken.

Before commencing testing, notify all areas where the alarm sounds and off-premises locations that receive alarm and trouble transmissions that testing is in progress.

Records of all testing and maintenance shall be kept on the protected premises for a period of at least five (5) years.

Required Tools:

- Slotted screwdriver, insulated
- Digital multimeter
- 12inch (30.5 cm) jumper lead with alligator clips
- Panel door key

A complete check of installed field wiring and devices should be made at regular intervals, in accordance with NFPA 72 and ULC 524 requirements. These requirements are covered in the chapter on preventive maintenance.

Control and emergency communications equipment testing

The procedures listed in the following sections should be performed on the equipment installed in each cabinet connected to the system. These procedures are designed to test the hardware and its installation. The applications programming will be tested later.

Note: The network configuration information must be downloaded into the network and Audio Source Unit, using the *System Definition Utility* (SDU) program, before starting testing.

Primary power supplies

1. Verify that all components are installed using accepted workmanship standards.
2. Verify adequate separation between power-limited and nonpower-limited wiring. Refer to NFPA 70, article 760, of the National Electrical Code.
3. Verify that the installed batteries are the proper capacity for the application.
4. With the batteries disconnected, verify that the supply's full alarm load can be sustained by the power supply without the batteries connected.
5. With the batteries connected, disconnect the AC source and verify that a power supply trouble is annunciated, and that the supply's full alarm load can be sustained by the batteries.
6. Verify that the battery charger properly charges the batteries connected to both the primary and booster power supplies to 80% capacity within 24 hours.

Booster power supplies

1. Verify that all components are installed using accepted workmanship standards.
2. Verify adequate separation between power-limited and nonpower-limited wiring.
3. Verify that the installed batteries are the proper capacity for the application.
4. With the batteries *disconnected*, verify that the supply's full alarm load can be sustained by the power supply without the batteries connected.
5. With the batteries connected, disconnect the AC source and verify that a power supply trouble is annunciated, and that the supply's full alarm load can be sustained by the batteries.

CPU with LCD module

1. Verify the module is properly seated in all four rail connectors and secured with the four snap rivets. Verify that removable terminal strips TB1 and TB2 are firmly seated.
2. Verify that all components are installed using accepted workmanship standards.
3. Verify that the correct date and time are displayed on the LCD module's display, and the Power LED is on.
4. Activate the lamp test and verify all lamps operated as follows:

Select the Command Menus button to obtain the Main Menu screen.

Select Test to obtain the Test Menu screen, then select Lamp Test.

5. Initiate a fire alarm and verify the following: the alarm LED flashes, the Alarm relay transfers, the correct device message appears at the top of the LCD window, the active point counter increments, the event sequence indicates a "1," the active Alarm events counter at the bottom of the display indicates A001, the event type indicates fire alarm, and the local panel buzzer sounds.

Press the Alarm Silence switch and verify that the required notification appliances are silenced and the Alarm Silence LED lights.

Press the Panel Silence switch to verify that the panel buzzer silences and the Panel Silence LED lights.

Press the Alarm queue switch and verify that the Alarm LED lights steady.

Press the Details switch and verify that the alarm device's message, if any, is displayed. If a printer is connected to the CPU, verify that all specified information appears on the printer.

6. Initiate a second fire alarm and verify that: it appears at the bottom of the LCD window, the active point counter changes, the event sequence indicates a "2," the active Alarm events counter at the bottom of the display indicates A002, the event type indicates fire alarm, the Alarm LED flashes again, the local panel buzzer resounds, and the *first* Alarm message remains at the top of the LCD window. Press the Alarm queue switch and verify that the Alarm LED lights steady.
7. Initiate a third fire alarm and verify that: its message appears at the bottom of the LCD window, the active point counter

- changes, the event sequence indicates a “3,” the active Alarm events counter at the bottom of the display indicates A003, the event type indicates fire alarm, and the local panel buzzer resounds, and the first alarm message remains at the top of the LCD window. Press the Alarm queue switch and verify that the Alarm LED lights steady.
8. Use the previous and next message switches to verify that you can scroll through all three messages in the alarm queue, as indicated by the event sequence window.
 9. Press the Reset switch. Verify that all initiating devices reset and that all panel indicators clear except the power LED.
 10. Initiate an active Monitor condition and verify that: the Monitor LED flashes, the correct active Monitor device message appears in the top and bottom windows of the LCD, the active point counter changes, the event sequence indicates a “1,” the active Monitor events counter at the bottom of the display indicates M001, and the event type indicates Monitor. Press the Monitor queue switch and verify that the Monitor LED lights steady. Initiate a second active Monitor condition and verify that the first Monitor message remains at the top of the LCD window, that the second Monitor event message appears at the bottom of the display, the active point counter changes, the event sequence indicates a “2,” the active Monitor events counter at the bottom of the display indicates M002.
 11. Initiate an active Trouble condition and verify that: the Trouble LED flashes, the correct active Trouble device message appears in the top and bottom windows of the LCD, the local panel buzzer sounds, the Trouble relay transfers, the active point counter changes, the event sequence indicates a “1,” the active Trouble events counter at the bottom of the display indicates T001, and the event type indicates Trouble. Press the Trouble queue switch and verify that the Trouble LED lights steady. Press the Panel Silence switch to verify the panel buzzer silences and the Panel Silenced LED lights. Initiate a second active Trouble condition and verify that the first Trouble message remains at the top of the LCD window, that the second Trouble event message appears at the bottom of the display, the active point counter changes, the event sequence indicates a “2,” the active Trouble events counter at the bottom of the display indicates T002.
 12. Initiate an active Supervisory condition and verify that the Supervisory LED flashes, the correct active Supervisory device message appears in the top and bottom windows of the LCD, the local panel buzzer sounds, the Supervisory relay transfers, the active point counter changes, the event

sequence indicates a “1,” the active Supervisory events counter at the bottom of the display indicates S001 and the event type indicates Supervisory. Press the Supervisory queue switch and verify that the Supervisory LED lights steady. Press the Panel Silence switch to verify the panel buzzer silences and the Panel Silenced LED lights. Initiate a second active Supervisory condition and verify that the first Supervisory message remains at the top of the LCD window, that the second Supervisory event message appears at the bottom of the display, the active point counter changes, the event sequence indicates a “2,” the active Supervisory events counter at the bottom of the display indicates S002.

13. Initiate an active fire Alarm, verify that alarm LED flashes, the correct fire alarm message appears in the top and bottom windows of the LCD the active point counter changes, the event sequence indicates a “1,” the active fire alarm events counter at the bottom of the display indicates A001 and the event type indicates fire alarm. Press the Alarm queue switch and verify that the Alarm LED lights steady. Press the Panel Silence switch to verify the panel buzzer silences and the Panel Silenced LED lights. Initiate a second fire Alarm condition and verify that the first fire Alarm message remains at the top of the LCD window, that the second fire Alarm event message appears at the bottom of the display, the active point counter changes, the event sequence indicates a “2,” the active fire alarm events counter at the bottom of the display indicates A002.
14. Press the Reset switch and verify that all devices reset and the panel returns to the normal condition.

3-RS232 card installed in CPU

1. Verify the card is properly seated in its connector and secured with the snap rivet.
2. Verify that the baud rate of the peripheral device connected to the port matches the port setting as set using the SDU program.
3. Check the printer operation by initiating an active condition on the system or generating a system report via the keypad.

3-RS485 card installed in CPU, Class B configuration

1. Verify the card is properly seated in its connector and secured with the snap rivet.

2. Starting with the network in the normal condition, use the status command to verify all connected cabinets are communicating over the network.
3. Disconnect the network data communications wiring (TB2-17/18 & 19/20) from the cabinet with the primary LCD module, and verify that all the other system cabinets connected to the network appear in the trouble queue.

3-RS485 card installed in CPU, Class A configuration

1. Verify the card is properly seated in its connector and secured with the snap rivet.
2. Starting with the network in the normal condition, use the status command to verify all connected cabinets are communicating over the network.
3. Disconnect the network data communications wiring (TB2-17/18 & 19/20) from the cabinet with the primary LCD module and verify that a Class A network communications fault is annunciated. Repeat step 2 to verify that all connected cabinets still communicate over the network.

3-IDC8/4 Initiating Device Circuit module

1. Familiarize yourself with the circuit configuration of the individual module to be tested. Remember, modules of the same type can be configured differently.
2. For circuits configured as initiating device circuits (IDCs), activate the circuit by shorting the circuit's two terminals. Verify that the appropriate message appears in the proper message queue. Disconnect the circuit or EOL resistor. Verify that a Trouble message appears in the Trouble message queue.
3. For circuits configured as Notification Device Circuits (NACs), turn on the circuit by activating an IDC programmed to turn on the NAC, or use the activate output device command via the keypad. Verify that the circuit activates properly. Restore the circuit. Disconnect the circuit or EOL resistor. Verify that a Trouble message appears in the Trouble message queue.

3-SSDC(1) Signature Driver Controller module

1. Verify that the module is properly seated in both rail connectors and secured with the two snap rivets. Verify that removable terminal strips TB1 and TB2 are firmly seated.

2. Verify the wiring to all Signature devices.
3. Map the SDC circuit by reading the device data; adjusting, modifying, and accepting devices as required; writing the information back to the devices; and rereading the device data.
4. With no map errors displayed, put an input device on the circuit in the active mode, and verify the appropriate message is displayed on the LCD module. Put the input device in the Trouble mode and verify that the correct Trouble message is displayed.

Note: Individual device testing will be done later.

3-AADC(1) Addressable Analog Driver Controller module

1. Verify that the module is properly seated in both rail connectors and secured with the two snap rivets. Verify that removable terminal strip TB1 is firmly seated.
2. Verify the wiring to all addressable analog devices.
3. Read the addressable analog circuit device data; adjusting, modifying, and accepting devices as required; writing the information back to the addressable analog module.
4. With no errors displayed, put an input device on the circuit in the active mode, and verify the appropriate message is displayed on the LCD module. Put the input device in the Trouble mode and verify that the correct Trouble message is displayed.

Note: Individual device testing will be done later.

3-OPS Off-premises Signaling module

1. Verify that the module is properly seated in both rail connectors and secured with the two snap rivets. Verify that removable terminal strip TB1 is firmly seated.
2. Familiarize yourself with the configuration of the module to be tested.
3. If the module is connected to a municipal box or central station, advise the appropriate parties that testing is in progress.
- 4a. Local Energy Municipal Box (City-Tie) configuration: With the municipal box connected between TB1-2 and TB1-3, open the circuit. (Note: You can temporarily substitute a 15 Ω , 2W resistor for the municipal box.) Verify that the module Trouble activates and the appropriate Trouble message appears in the Trouble message queue. Reconnect

the circuit and initiate an active fire alarm. You should measure 20 to 25 volts between TB1-3 (+) and TB1-4 (-). Press the panel Reset switch, and wait for the system to reset. Verify receipt of the alarm at the municipal receiving station.

Note: If you activate the municipal box, it will indicate Trouble until rewind.

- 4b. Single Reverse Polarity Circuit (Old Style) configuration: Verify that 20 to 25 volts appears between TB1-5 (+) and TB1-6 (-), paying attention to polarity. Create a Trouble condition on the panel. Verify that 0 volts appears between TB1-5 (+) and TB1-6 (-). Verify that the module's Trouble relay activates, the appropriate Trouble message appears in the Trouble message queue, and that the receiving station receives the Trouble indication. Open the circuit wired between TB1-5 and TB1-6. Verify that the receiving station receives the Trouble indication.

Initiate an active fire alarm. You should measure 20 to 25 volts between TB1-5 (-) and TB1-6 (+), paying attention to the polarity change. Verify receipt of the alarm at the municipal receiving station.

- 4c. Three Reverse Polarity Circuit (New Style) configuration: Verify that 20 to 25 volts appears between TB1-5 (+) & TB1-6 (-), between TB1-7 (+) & TB1-8 (-), between TB1-9 (+) & TB1-10 (-), paying attention to polarity. Create a Trouble condition on the panel. Verify that 20 to 25 volts appears between TB1-8 (+) and TB1-8 (-). Verify that the module's Trouble relay activates, the appropriate Trouble message appears in the Trouble message queue, and that the receiving station receives the *Trouble* indication. Open the circuit wired between TB1-5 and TB1-6. Verify that the receiving station receives a *circuit fault* indication. Open the circuit wired between TB1-7 and TB1-8. Verify that the receiving station receives a *circuit fault* indication. Open the circuit wired between TB1-9 and TB1-10. Verify that the module's Trouble relay activates and the appropriate Trouble message appears in the Trouble message queue, and that the receiving station receives a *circuit fault* indication.

Initiate an active fire alarm. You should measure 20 to 25 volts between TB1-5 (-) and TB1-6 (+), paying attention to the polarity change. Verify receipt of the alarm at the municipal receiving station.

Initiate an active Supervisory condition. You should measure 20 to 25 volts between TB1-9 (-) and TB1-10 (+), paying attention to the polarity change. Verify receipt of the Supervisory condition at the municipal receiving station.

3-ASU Audio Source Unit

1. Verify that the 3-ASU is installed using accepted workmanship standards.
2. The audio sub-system messages and configuration information must be downloaded into the Audio Source Unit, using the System Definition Utility (SDU) program, before starting testing. Verify that the 3-ASUMX expansion card, if used, is firmly seated in its connector.
3. Verify the wiring to all devices.
4. Starting with the network in the normal condition, use the Status command to verify all amplifiers are communicating over the network.
5. Disconnect the network audio communications wiring (TB1-1/2) from the 3-ASU, and verify that all the audio amplifiers connected to the network appear in the Trouble queue. Restore the connection.
6. If a supervised remote microphone is used, disconnect the remote microphone wiring (TB1-11 & TB1-12) from the 3-ASU. Verify a remote microphone trouble is annunciated.
7. Press the All Call switch on the front of the 3-ASU. Verify the All Call LED next to the switch lights. Remove the microphone from its bracket, press the Push-To-Talk (PTT) switch. Verify that the preannouncement tone (if configured) sounds, followed by the Ready to Page LED lighting. Speak into the microphone and verify that the Page Level Meter is operational, and the message is being transmitted over all speakers.

3-FTCU Firefighter Telephone Unit

1. Verify that the 3-FTCU is installed using accepted workmanship standards.
2. Verify the wiring to all devices. The SIGA-CC1 should be set to personality code 6.
3. Verify that the 3-FTCU display indicates: “0 Calls Pending” and “Unit: OK.”
4. Take the master handset off-hook. Verify that the display indicates: “Handset off hook..” Replace the master handset on-hook.
5. Take a firefighter telephone off-hook (plug a phone in a phone jack). Verify that the incoming call buzzer sounds, the display indicates “1 Calls Pending,” the location of the incoming call is displayed in reversed text, and “0 calls connected” is shown on the display. Silence the buzzer by

pressing the ACK switch. Press the Connect switch. Verify that the display indicates: “0 calls pending,” “1 calls connected,” and the location of the connected call is displayed in reversed text. Converse over the phone connection to verify clear, noise free communications.

Take a second firefighter telephone *on a different circuit* off-hook. Verify that the incoming call buzzer sounds, the display indicates “1 Calls Pending,” the location of the incoming call is displayed in reversed text, and “1 calls connected” is shown in the display. Silence the buzzer by pressing the ACK switch. Press the Connect switch. Verify that the display indicates: “0 calls pending,” “2 calls connected,” the location of the second connected call is displayed in reversed text, the location of the first call is displayed in normal text below the second call location. Converse over the phone connection to verify clear, noise free communications.

Press the Review Connected switch, moving the reversed text to the first call’s location message. Without hanging up the first telephone, press the Disconnect switch. Verify the display indicates: “1 Calls Pending,” the location of the call being disconnected is displayed in reversed text at the top of the screen, and “1 calls connected” is shown in the display. Hang up the first telephone. Verify that the display indicates: “0 Calls Pending” and “1 calls connected.”

6. Repeat Step 5, connecting five (5) phones simultaneously, and verify acceptable voice quality.
7. Press the All Call and Page by Phone switches on the 3-ASU Audio Source Unit. When the Ready to Page LED lights *steady*, speak into the telephone still connected, and verify that the telephone’s audio is distributed throughout the facility. Press the Disconnect switch on the 3-FTCU, and hang up the master and remote phones.
- 8a. *Class A telephone riser configuration:* Disconnect the telephone riser wiring (TB1-2 & TB1-2) or (TB1-3 & TB1-4) from the 3-FTCU, and verify that a riser trouble message appears in the Trouble queue. Take a firefighter telephone off-hook (plug a phone in a phone jack). Verify that the incoming call buzzer sounds, the display indicates “1 Calls Pending,” the location of the incoming call is displayed in reversed text, and “0 calls connected” is shown in the display. Restore the connection.
- 8b. *Class B telephone riser configuration:* Disconnect the telephone riser wiring (TB1-1 & TB1-2) from the 3-FTCU, and verify that a riser trouble message appears in the Trouble queue. Restore the connection.

9. Disconnect each phone station/jack station, and verify that a Trouble message appears in the Trouble queue. Restore the connections.

3-ZAxx Audio Amplifiers

1. Verify that the module is properly seated in both rail connectors and secured with the two snap rivets. Verify that removable terminal strips are firmly seated.
2. Verify that the 3-ASU is installed using accepted workmanship standards.
3. If wired with a backup amplifier, verify that the backup amplifier's wattage is equal to or greater than the wattage of any primary amplifier it can replace. If mixing 15-, and 30-watt amplifiers with 20-, and 40-watt amplifier modules, make sure the back up amplifier is 20 or 40 watts, whichever is required.
4. Verify that the EVAC and Page signals are available at the speakers
5. Create an amplifier fault. Verify backup amplifier substitution.
6. *Class B amp output configuration:* Disconnect the module's audio output wiring (TB2-7 & TB2-8) from the 3-ZAxx, and verify that the appropriate amplifier Trouble message appears in the Trouble queue. Restore the connection.
7. *Class B supplementary NAC output configuration (3-ZA20 & 3-ZA40 only):* Disconnect the module's supplementary notification appliance circuit wiring (TB2-3 & TB2-4) from the 3-ZAxx, and verify that the appropriate Trouble message appears in the Trouble queue. Restore the connection. Short the module's supplementary notification appliance circuit wiring (TB2-3 & TB2-4) from the 3-ZAxx, and verify that the appropriate Trouble message appears in the Trouble queue. Remove the short.

Control/display modules

1. Verify that the display(s) are properly seated in the module and secured with the four snap rivets. Verify that the ribbon cable between the display and its host module is firmly seated on both ends.
2. Activate the lamp test and verify all lamps operated as follows:

Select the Command Menus button to obtain the Main Menu screen.

Select Test to obtain the Test Menu screen, then select Lamp Test.

2. Perform a functional switch test

Amplifier transfer panel (ATP)

1. Disconnect power amplifier output. Verify amplifier/riser trouble annunciated on panel. Restore connection.
2. Initiate an All Call page. Verify that audio is available on all power amplifier outputs.
3. If back up amplifiers provided, create an amplifier failure and verify backup amp operates properly.
4. Disconnect AC power from amplifier rack. Initiate an All Call page. Verify that audio is available on all power amplifier outputs.

Detector, input module, and output module testing

The procedures listed in this section should be performed on the detectors, input modules, output modules, and related accessories connected to each cabinet. These procedures are designed to test the devices and the network applications programming.

Note: The network configuration, Signature Control module information must be downloaded into the network and Audio Source Unit, using the System Definition Utility (SDU) program, before starting testing.

Every circuit connected to the EST3 system should be visited, and manually activated during the installation process to verify that:

1. The installed location meets proper engineering practices.
2. The location annunciated by the system agrees with the physical location of the device.
3. That the activated device initiates the correct system response.

Duct detectors should be tested to verify that both minimum and maximum airflow requirements are met.

Signature Series detectors and bases on a 3-SSDC(1) module circuit

1. Verify that all components are installed using accepted workmanship standards.
2. Individually activate each detector. Verify that the appropriate Alarm and location message is displayed on the LCD module. Verify that the detector initiates the appropriate system responses. If the detector is installed in a relay base, verify that the base's relay function operates correctly. If the detector is installed in an isolator base, verify that the base isolates the required circuit segments.

Caution: Do not use magnets to test Signature series detectors. Doing so may damage the detector electronics. Instead, use an approved testing agent (e.g. canned smoke.)

3. Duct mounted detectors should be tested using an air velocity test kit (6263, 6263-SG) to verify that minimum/maximum airflow requirements are met.
4. Remove the detector from its base. Verify that the appropriate Trouble and location message is displayed on the LCD module.

5. After all detectors have been individually inspected, run a Sensitivity report, using the Reports command.

Addressable analog detectors on a 3-AADC(1) Module circuit

1. Verify that all components are installed using accepted workmanship standards.
2. Individually activate each detector. Verify that the appropriate Alarm and location message is displayed on the LCD module. Verify that the detector initiates the appropriate system responses.
3. Duct mounted detectors should be tested to verify that minimum/maximum airflow requirements are met.
4. Remove the detector from its base. Verify that the appropriate Trouble and location message is displayed on the LCD module.
5. After all detectors have been individually inspected, run a Sensitivity report, using the Reports command.

Traditional 2-wire smoke detectors connected to 3-IDC8/4 modules

1. Verify that all components are installed using accepted workmanship standards.
2. Individually activate each detector. Verify that the appropriate Alarm and location message is displayed on the LCD module. Verify the detector circuit initiates the appropriate system responses.
3. Duct mounted detectors should be tested to verify that minimum/maximum airflow requirements are met.
4. Remove the detector from its base. Verify that the appropriate circuit Trouble and location message is displayed on the LCD module.

Conventional 2-wire smoke detectors connected to SIGA-UM modules

1. Verify that all components are installed using accepted workmanship standards.
2. Verify that jumper JP1 on each SIGA-UM module is set to position 1/2.
3. Individually activate each detector. Verify that the appropriate Alarm and location message is displayed on the

LCD module. Verify the SIGA-UM initiates the appropriate system responses.

4. Duct mounted detectors should be tested to verify that minimum/maximum airflow requirements are met.
5. Remove the detector from its base. Verify that the appropriate SIGA-UM Trouble and location message is displayed on the LCD module.

Signature series input modules

1. Verify that all components are installed using accepted workmanship standards.
2. Individually activate each initiation device. Verify that the appropriate circuit type and location message is displayed on the LCD module. Verify that the circuit initiates the appropriate system responses.
3. Open up the circuit. Verify that the appropriate circuit Trouble and location message is displayed on the LCD module.

Signature series output modules

1. Verify that all components are installed using accepted workmanship standards.
2. Using the Activate Output command, individually activate each output. Verify that the device responds appropriately.
3. For supervised output circuits, open up the circuit. Verify that the appropriate circuit Trouble and location message is displayed on the LCD module.
4. If the output is activated by one or more system inputs, activate these inputs and verify the output function operates appropriately.

Initiating device testing

The procedures listed in the following sections should be performed on the initiating devices connected to the system, in conjunction with the procedures in the topic “Detector, input module, and output module initial and reacceptance testing.” These procedures are designed to test the initiating devices and the network applications programming.

Manual stations

1. Visual inspection
2. Activate mechanism
3. Verify that the appropriate circuit type and device location message is displayed on the LCD module. Verify the device initiates the appropriate system responses.
4. Open up the circuit. Verify that the appropriate circuit Trouble and location message is displayed on the LCD module.

Nonrestorable heat detectors

1. Visual inspection
2. Test mechanically and/or electrically
3. Verify that the appropriate circuit type and device location message is displayed on the LCD module. Verify the device initiates the appropriate system responses.
4. Open up the circuit. Verify that the appropriate circuit Trouble and location message is displayed on the LCD module.

Restorable heat detectors

1. Visual inspection
2. Activate detector
3. Verify that the appropriate circuit type and device location message is displayed on the LCD module. Verify the device initiates the appropriate system responses.
4. Open up the circuit. Verify that the appropriate circuit Trouble and location message is displayed on the LCD module.

Waterflow switches

1. Visual inspection

Power-up and testing

2. Activate sprinkler test valve. (Refer to Sprinkler system test procedure.)
3. Verify that the appropriate circuit type and device location message is displayed on the LCD module. Verify the device initiates the appropriate system responses.
4. Open up the circuit. Verify that the appropriate circuit Trouble and location message is displayed on the LCD module.

Notification appliance testing

The procedures listed in the following sections should be performed on the notification appliances connected to the system, in conjunction with the procedures in “Detector, input module, and output module initial and reacceptance testing.” These procedures are designed to test the notification appliances and the network applications programming.

Visual devices

1. Visual Inspection
2. Activate the circuit. Verify all indicating appliances operating properly.
3. Open up the circuit. Verify that the appropriate circuit Trouble and location message is displayed on the LCD module.

Speakers

1. Visual Inspection
2. Activate the circuit. Verify all indicating appliances operating properly.
3. Open up the circuit. Verify that the appropriate circuit Trouble and location message is displayed on the LCD module.

Bells and horns

1. Visual Inspection
2. Activate the circuit. Verify all indicating appliances operating properly.
3. Open up the circuit. Verify that the appropriate circuit Trouble and location message is displayed on the LCD module.

Record of completion

When the system has been tested and found to operate satisfactorily, make a copy and fill out the Record of Completion on the following pages, and mount it near the fire alarm panel or give it to the building representative.

Record of Completion		Page 1 of 2
Protected Property		
Name: _____	Authority Having Jurisdiction: _____	
Address: _____	Address: _____	
Representative: _____	Phone: _____	
Phone: _____		
Record of System Installation		
This system has been installed in accordance with the NFPA standards listed below, was inspected by _____ on _____, and includes the devices listed below, and has been in service since _____.		
<input type="checkbox"/> NFPA 72: Year _____; Ch. 1 2 3 4 5 6 7 (circle all that apply) <input type="checkbox"/> NFPA 70, <i>National Electrical Code</i> , Article 760 <input type="checkbox"/> Manufacturer's Instructions <input type="checkbox"/> Other (specify): _____		
Record of System Operation		
All operational features and functions of this system were tested by _____ on _____ and found to be operating properly and in accordance with the requirements of:		
<input type="checkbox"/> NFPA 72: Year _____; Ch. 1 2 3 4 5 6 7 circle all that apply <input type="checkbox"/> NFPA 70, <i>National Electrical Code</i> , Article 760 <input type="checkbox"/> Manufacturer's Instructions <input type="checkbox"/> Other (specify): _____ Signed: _____ Dated: _____ Organization: _____		
System Software		
System Firmware		
Installed Revision: _____ Checksum: _____ Date: _____		
Application Programming		
Initial Program Installation: _____		Date: _____
Revisions & Reasons: _____		Date: _____
Programmed by (name): _____		Date: _____
Date of Programmer's Latest Factory Certification: _____		
Data Entry Program Revision Used _____		
Maintenance		
Frequency of routine tests and inspections, if other than in accordance with the referenced NFPA standards: _____		
System deviations from the referenced standards are: _____		

(signed) for Central Station or Alarm Service Company		(title) (date)
(signed) for representative of the authority having jurisdiction		(title) (date)
[EST3ROC1.CDR]		

Record of Completion

Initiating Devices and Circuits

(indicate quantity)

___ Manual Stations

Automatic Devices

___ Smoke Detectors: ___ Ion ___ Photo

___ Duct Detectors: ___ Ion ___ Photo

___ Waterflow Switches: _____

___ Other (list): _____

Combination Detectors
(circle active sensors)

___ Ion/Photo/Heat

___ Ion/Photo/Heat

Supervisory Devices and Circuits

(indicate quantity)

___ Compulsory Guard's Tour comprised of ___ transmitter stations and ___ intermediate stations.

Sprinkler System

___ Valve supervisory devices

___ Building temperature points

___ Site water temperature points

___ Site water supply level points:

Engine Driven Fire Pump

___ Selector in auto position

___ Control panel trouble

___ Transfer switches

___ Engine running

Electric Fire Pump

___ Fire pump power

___ Fire pump running

___ Phase reversal

Other Supervisory Function(s)
(specify)

Notification Appliances & Circuits

Notification Appliance Circuits _____

Type and quantity of installed Notification Appliances

___ Bells ___ inch ___ Visual Signals Type: _____

___ Speakers ___ with audible

___ Horns ___ without audible

___ Other: _____

___ Local Annunciator

Signaling Line Circuits

Quantity and Style of connected SLCs, per NFPA 72, Table 3-6.1

___ Quantity ___ Style

System & Service

___ **NFPA 72 - Local**
If alarm transmitted off premise, location(s) received: _____

___ **NFPA 72 - Emergency Voice Alarm Service**

Voice/alarm channels: _____ Single: _____ Multiple: _____

Installed speakers: _____ # speakers per zone: _____

Telephones/jacks installed: _____

___ **NFPA 72 - Auxiliary**

Type of connection: _____

Local Energy: _____ Shunt: _____ Parallel Telephone: _____

Location/Phone # for receipt of signals: _____

___ **NFPA 72 - Remote Station**

Alarm: _____

Supervisory: _____

___ **NFPA 72 - Proprietary**

If alarms retransmitted off premise, location & phone of receiving organization: _____

Method of alarm retransmission: _____

___ **NFPA 72 - Central Station**

Prime Contractor: _____

Central Station Location: _____

Method of transmission of alarms to central station:

___ McCulloch ___ One-Way Radio ___ Digital Alarm Communicator

___ Multiplex ___ Two-Way Radio ___ Others: _____

Method of transmission of alarms to public fire service communications center:

1. _____ 2. _____

Power Supplies

Primary (main)	Secondary (standby)
Nominal Voltage: _____	Storage battery _____
Current Rating: _____	Amp-Hour rating: _____
Overcurrent protection: _____	Calculated for _____ hours of system operation.
Type: _____	Current rating: _____
Location: _____	___ Dedicated generator
	Location of fuel supply: _____

Emergency or standby system used to backup primary supply

___ Emergency system described in NFPA 70, Article 700

___ Legally required standby system described in NFPA 70, Article 701

___ Optional standby system described in NFPA 70, Article 702, meeting the performance requirements of Article 700 or 701

Preventive maintenance

Summary

This chapter provides a listing of required scheduled maintenance items and procedures.

Content

- General • 7.2
- Preventive maintenance schedule • 7.3
- Signature device routine maintenance tips • 7.5
 - Detectors • 7.5
 - Modules • 7.5
- Signature detector cleaning procedure • 7.6
- System trouble and maintenance log • 7.7

General

Before commencing testing, notify all areas where the alarm sounds and off premises locations that receive alarm and trouble transmissions that testing is in progress.

Records of all testing and maintenance shall be kept on the protected premises for a period of at least five (5) years.

Required Tools:

- Slotted Screwdriver, Insulated
- Digital multimeter
- 1.1 k Ω 1 W resistor
- 12 inch (30.5 cm) jumper lead with alligator clips
- Panel Door Key

In addition, make sure you have the required system passwords. If the system includes access control applications, you'll need a construction card, or other valid access card.

A complete check of installed field wiring and devices should be made at regular intervals, in accordance with NFPA 72 and ULC 524 requirements. This includes testing all alarm and supervisory alarm initiating devices and circuits, and any off premise connections.

Panel operation should be verified in the alarm, supervisory, and trouble modes.

To ensure that the panel can be powered when primary power is lost, the batteries should be periodically inspected, tested, and replaced (as a minimum) every 4 years.

Preventive maintenance schedule

Preventive maintenance schedule

Component	Testing Interval	Test Procedure
Manual stations	Semiannually	<ol style="list-style-type: none"> 1. Visual inspection 2. Put zone in Test mode 3. Activate mechanism 4. Verify proper IDC zone response
Non-restorable heat detectors	Semiannually	<ol style="list-style-type: none"> 1. Visual inspection 2. Put zone in Test mode 3. Test mechanically and/or electrically 4. Verify proper IDC zone response
Restorable heat detectors	Semiannually	<ol style="list-style-type: none"> 1. Visual Inspection 2. Put zone in Test mode 3. Activate at least one detector on each IDC. All detectors on each IDC must be tested within five years.
Smoke detectors	Annually	<ol style="list-style-type: none"> 1. Visual inspection 2. Put zone in test mode 3. Conduct a Functional test to verify proper IDC zone response 4. Check sensitivity 5. Clean as required
Waterflow switches	Every two months	<ol style="list-style-type: none"> 1. Put zone in Test mode 2. Activate sprinkler test valve. Refer to Sprinkler system test procedure.
All initiating device circuits	Annually	<ol style="list-style-type: none"> 1. Enter Test mode 2. Activate IDC zone. Appropriate NACs should activate and zone information should be annunciated. 3. Restore device and reset zone 4. Open the IDC field wiring. Trouble should be annunciated. 5. Reset and lock panel at conclusion of all testing
Remote annunciators	Annually	<ol style="list-style-type: none"> 1. Verify all indicators operating properly.
Notification appliances	Annually	<ol style="list-style-type: none"> 1. Visual Inspection 2. Put panel in Alarm, Drill, or Test mode. Verify that all indicating appliances are operating properly

Preventive maintenance

Preventive maintenance schedule

Component	Testing Interval	Test Procedure
Panel LEDs and trouble buzzer	Annually	<ol style="list-style-type: none"> 1. Illuminate all LEDs by pressing the Panel Silence and Trouble Silence switches at the same time 2. Reset and lock panel at conclusion of all testing
Panel primary power	Acceptance and reacceptance tests	<ol style="list-style-type: none"> 1. Remove Primary AC power 2. Verify panel operates from battery 3. Verify panel goes into trouble (6 second delay) 4. Restore AC power at end of test 5. Reset and lock panel at conclusion of all testing
Panel secondary power	Acceptance and reacceptance tests	<ol style="list-style-type: none"> 1. Remove primary AC power 2. Measure standby and alarm currents, and compare with battery calculations to verify adequate battery capacity. 3. Test under full load for 5 minutes 4. Measure battery voltage under full load (20.4 to 27.3 Vdc) 5. Restore AC power at end of test 6. Reset and lock panel at conclusion of all testing
Panel trouble signals	Annually	<ol style="list-style-type: none"> 1. Verify operation of system Trouble LED and trouble buzzer 2. Reset and lock panel at conclusion of all testing
LCD clock	Each visit	Verify displayed time is correct. Reset clock if incorrect.
Supervisory signal initiating devices	Semiannually	<ol style="list-style-type: none"> 1. Put zone in Test mode 2. Operate valve 3. Test pressure, temperature, and water level sensors per the sprinkler system test procedure
Auxiliary system off-premises fire alarm signal transmission	Monthly	<ol style="list-style-type: none"> 1. Coordinate test with receiving location 2. Verify receipt of all transmitted signals 3. Reset and lock panel at conclusion of all testing
Remote system off-premises waterflow signal transmission	Every two months	<ol style="list-style-type: none"> 1. Coordinate test with receiving location 2. Verify receipt of all transmitted signals 3. Reset and lock panel at conclusion of all testing

Signature device routine maintenance tips

Detectors

When removing one detector at a time, wait 1 minute after replacing the first detector before removing the next detector. This gives the system time to recognize and re-map the first detector before generating a trouble condition caused by removing the second detector.

Modules

Signature modules should be visually inspected to insure the physical installation is secure. Functional testing of the module should be done regularly as required by the AHJ.

Signature detector cleaning procedure

Signature detectors may be cleaned using a conventional vacuum cleaner with the detector cleaning tool (P/N SIGA-ST) installed on the end of the suction hose (nominal 1.5 in. [3.8 cm] ID) extension tubes. The tool creates a high velocity vortex scrubbing action around the detector, removing loose dust and debris which is subsequently drawn into the vacuum.

Note: In order to avoid false alarms, disable the detector being cleaned before using the detector cleaning tool.

1. Disable the detector to prevent false alarms.
2. Use the conventional vacuum cleaner brush attachment to remove any visible cobwebs etc. from the immediate area of the detector.
3. Connect the detector cleaning tool to the suction hose.
4. Place the detector cleaning tool over the detector head for approximately 10 seconds.
5. After the detector has been cleaned, Restore it to proper operation.
6. Check the detector's sensitivity to verify the effectiveness of the cleaning.

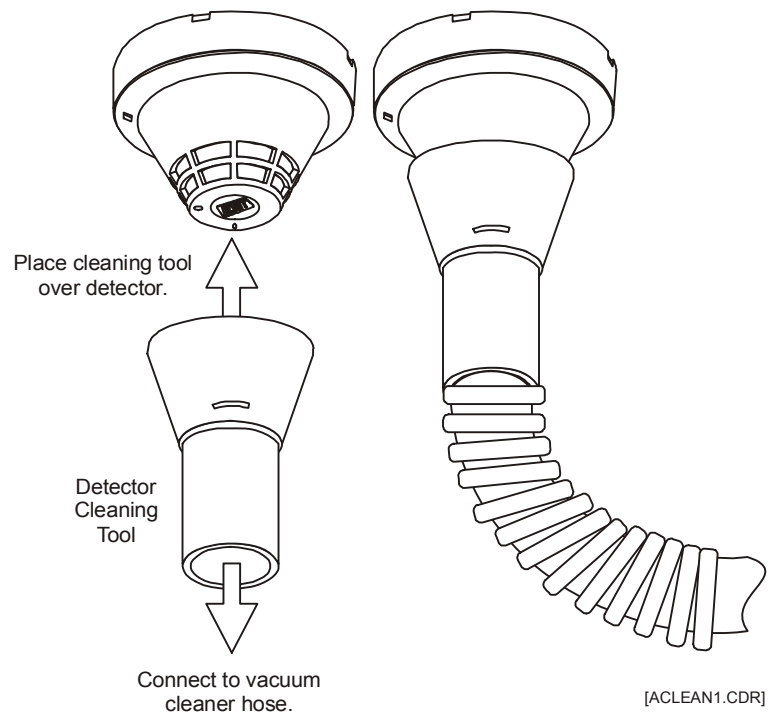

Figure 7-1: Detector Cleaning Tool

System trouble and maintenance log

Date	Time	Event	Initial

Preventive maintenance

Service and troubleshooting

Summary

This chapter provides a comprehensive set of procedures and tables to aid certified technical personnel in servicing and troubleshooting the system.

Content

Overview • 8.3

- Maintenance philosophy • 8.3

- Problem classification • 8.3

- Handling static-sensitive circuit modules • 8.3

- Removing or replacing circuit modules • 8.4

- Recommended spares list • 8.4

Hardware problems • 8.5

- Identification • 8.5

- Isolation • 8.5

- Substituting hardware • 8.5

- Adding hardware • 8.6

- Downloading problems • 8.6

Modules • 8.7

- Rail signals • 8.7

- 3-PPS/M Primary Power Supply module • 8.7

- 3-BPS/M Booster Power Supply module • 8.9

- CPU Central Processor module • 8.9

- 3-FIBMB fiber optic interface • 8.13

- Signature Controller modules • 8.14

- Control / display modules • 8.14

- Audio amplifier modules • 8.15

- 3-OPS Off-Premises Signal module • 8.16

- 3-IDC8/4 Initiating Device Circuit module • 8.16

- 3-LDSM Display Support module • 8.17

- 3-MODCOM(P) Modem Communicator module • 8.17

- Common causes of problems • 8.18

Audio components • 8.20

- 3-ASU Audio Source Unit • 8.20

- 3-FTCU Firefighter Telephone Control Unit • 8.21

- SIGA audio amplifiers • 8.21

Pseudo point descriptions • 8.24

Signature data circuit (SDC) operation • 8.35

Basic Signature data circuit troubleshooting • 8.37

- Isolating circuit and device problems • 8.37

- Open circuit conditions • 8.37

- Short circuit conditions • 8.38

- Ground fault conditions • 8.39

- Substituting known good Signature series devices • 8.41

Signature controller modules • 8.47

Service and troubleshooting

- Substituting Signature controller modules • 8.47
- Mapping errors • 8.47
- Device troubleshooting • 8.49
- Signature diagnostic tools • 8.51
 - Using Signature diagnostics • 8.51
 - Signature diagnostic sequence • 8.52
 - Displaying mapping errors • 8.52
 - Displaying device chain errors • 8.55
 - Using the chain lists • 8.57
 - Displaying message counters • 8.57
 - Displaying device trouble • 8.59
 - Displaying trouble tables • 8.62
- DSDC status • 8.65
 - Introduction • 8.65
 - Setting up the System Definition Utility program • 8.65
 - Using DSDC status • 8.65
 - Displaying the current SDC status • 8.65
 - Displaying a log of current SDC status events • 8.67
 - Displaying the SDC in-process progress chart • 8.68
- Addressable analog diagnostic tools • 8.70
 - System definition utility • 8.70
 - Problem solving hints • 8.72
- 3-AADC1 Addressable Analog Driver Controller • 8.74
 - Substituting 3-AADC1 local rail modules • 8.74
- Addressable analog device troubleshooting • 8.75
- Wiring problems • 8.77
 - Correcting addressable analog circuit wiring problems • 8.78

Overview

Maintenance philosophy

The EST3 life safety system consists of modular assemblies utilizing surface mount technology (SMT) for easy installation and maintenance. SMT provides high reliability but prohibits component-level field repairs. For these and other reasons, the maintenance philosophy consists of fault isolating to the circuit card assembly, removing the defective circuit card, and then replacing it with a spare.

Service and repair of EST3 system components centers around the following assumptions:

1. Qualified technicians possessing a complete understanding of the system hardware and functions will perform maintenance.
2. Only certified maintenance technicians will service the equipment.
3. Maintenance technicians will have a ready available supply of replacement parts.

Problem classification

Problems with the system can generally be classified into two categories: application programming problems and hardware (including firmware) problems. Many times hardware problems are identified by the system itself. Application programming problems are typically suspected when an incorrect response happens, or when a response fails to happen or happens at the wrong time.

Handling static-sensitive circuit modules

Many of the circuit modules use components that are sensitive to static electricity. To reduce the possibility of damaging these components, take the following precautions when handling:

1. Use only approved grounding straps that are equipped with a 1 M Ω resistive path to earth ground.
2. Always keep circuit modules in their protective antistatic packaging. Remove only for inspection or installation.
3. Always hold circuit modules by the sides. Avoid touching component leads and connector pins.

Removing or replacing circuit modules

When removing or replacing circuit modules, always remember to:

1. First disconnect the battery then remove AC power.
Removing or replacing circuit modules when power is applied will damage the equipment.
2. Avoid applying excessive force to the snap-rivet fasteners that lock the plug-in modules in place. If needed, use the extraction tool provided in the hardware kit.

Recommended spares list

As a general guideline, 10% of the quantity installed or a minimum of 1 each of the following installed equipment should be available as spare:

- Power supply
- Local rail modules
- Amplifiers (if no backup installed in system)
- Printer ribbon

As a general guideline, 10% of the quantity installed or a minimum of 3 each of the following installed equipment should be available as spare:

- Monitor modules
- Control modules
- Heat detectors
- Ionization smoke detectors
- Photoelectric smoke detectors
- Base, detector
- Duct detector filter kits
- Breakglass replacement for pull stations
- Breakglass replacement for warden stations
- Horn, bell, strobe, and speaker

System batteries should be replaced at recommended intervals. Stocking of spare batteries is not recommended because of shelf-life limitations.

Hardware problems

Identification

Hardware problems are typically identified by an intermittent or total failure of a device.

Isolation

Hardware problems may be categorized as problems within an equipment cabinet, and problems with field wiring and devices.

The quickest way to locate a hardware problem is by selectively isolating portions of the system and observing the results of the isolation. By selectively isolating smaller and smaller portions of the system, hardware faults can usually be isolated. The suspect component may then be replaced with a known good component, and the results again observed.

Substituting hardware

Caution: Never install or remove a module while power is applied to the cabinet.

The local rail modules in the EST3 system are microprocessor based. The Signature driver controller module, Central Processor Module (CPU) module, 3-AADC1 Addressable Analog Device Controller module, and 3-ASU Audio Source Unit all have “flash” memory, which is used to store the operating firmware. The flash memory is empty when the module is shipped from the factory. When the configuration database is downloaded into the cabinet, each component using flash memory receives specific information. This information includes the module’s location in the system and its configuration.

Note: Because the content of each module is specific to its cabinet location, do not substitute 3-SSDC(1), CPU, 3-AADC1, or 3-ASU modules without downloading the new cabinet configuration database.

If you are substituting a Signature driver controller module, you must also download the specific Signature circuit information into the module’s memory. If you are substituting a 3-AADC1 driver controller module, you must also download its specific circuit configuration into its database. If you are substituting 3-ASU modules, you must also download the audio message database directly into the 3-ASU.

Rail module substitution and replacement rules

Rule 1: Modules must be replaced with modules of the same model number.

Rule 2: LED / Switch Displays must be replaced with LED / Switch Displays of the same model number.

Rule 3: Substitute modules *must* have an *identical* LED / Switch Display installed as the module it replaces.

Rule 4: Substitute modules should be installed in the same rail location as the module it is replacing.

Adding hardware

When hardware is added to a cabinet, a portion of the network configuration database must also be changed. The extent of the changes depends on the rule relationships between the added component and the balance of the network. Revised copies of the database must then be downloaded using the SDU.

Downloading problems

If you are experiencing frequent downloading problems, low signal level from the download computer may be the cause. The Buffered RS-232 Communication Cable, Catalog No. SDU-CBL, may be used to correct signal level problems.

Note: Do not use the buffered RS-232 communication cable with a CPU.

Modules

Rail signals

The figure below shows the signals normally present on a pair of chassis rails.

Note: The panel controller and the power supply monitor module must be installed in order to measure the voltages indicated.

Top Rail	
Pin	Function
1 - 2	+6.25 VDC
3	+Sense
4	-Sense
5	-Audio Data
6	+Audio Data
7	-Rail Data
8	+Rail Data
9 - 10	Not Used
11 - 14	Common

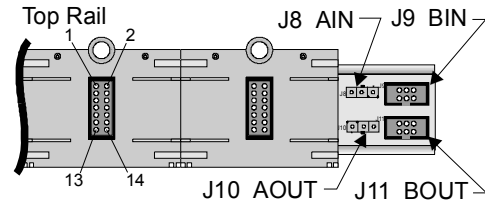

Bottom Rail	
Pin	Function
1 - 4	+24 VDC
5	All Fail
6 - 9	Not Used
10 - 12	Ground

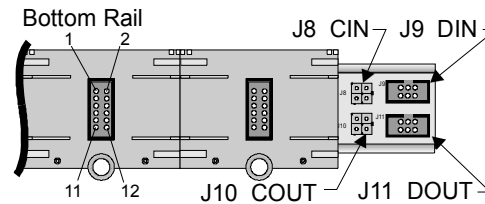

The DC voltages can be checked with a digital meter. Data signals on pins 7 and 8 of the top rail can be verified by looking at the Receive (RX) and Transmit (TX) LEDs on any module installed on the rail.

3-PPS/M Primary Power Supply module

The transmit (TX) and receive (RX) LEDs on the Primary Power Supply Monitor Module should flicker, indicating normal two way communication activity with the CPU.

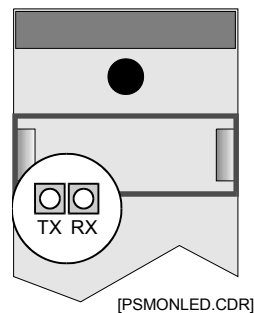

If the 3-PPS/M Primary Power Supply is used in conjunction with one or more 3-BPS/M Booster Power Supplies, there is

interaction between the supplies. Under most conditions, a defective power supply will be identified by the system, and annunciated as a trouble. The system may continue to operate nearly normally, as the battery connected to the faulty supply will automatically be switched into the circuit, as the load demands.

Table 8-1: Nominal primary and booster power supply voltages

Test Point	Voltage
Rail Power	25 - 26.4 Vdc w/AC power on
Auxiliary Power	25 - 26.4 Vdc w/AC power on
Battery	27.3 V (battery under charge @ 25 °C)

Table 8-2: Primary Power Supply module troubleshooting

Problem	Possible cause
Supply will not operate from AC line	<ol style="list-style-type: none"> 1. AC line fuse F2 (3.15A slow blow) open 2. Rectified DC fuse F3 (3.15A slow blow) open
RX or TX LED OFF No communication between 3-PSMON and CPU	<ol style="list-style-type: none"> 1. Defective or poor connection on ribbon cable between 3-PSMON and 3-PPS 2. 3-PSMON Defective 3. 3-PPS Defective
Auxiliary and Rail voltage low	<ol style="list-style-type: none"> 1. Excessive load causing supply to fold back 2. Power Cable between 3-PSMON and 3-PPS loose or defective 3. Booster Supply failure causing primary supply to fold back
Batteries will not charge	<ol style="list-style-type: none"> 1. System in alarm mode 2. Fuse F1 (8A) on 3-PPS open 3. 30 to 60 Ah battery installed, 10 to 29 Ah battery specified in SDU 4. Battery shorted 5. Battery not wired to power supplies correctly (only wired to BPS/M)
System will not operate on batteries	<ol style="list-style-type: none"> 1. Battery voltage below 18 Vdc. (system automatically turns off when batteries too low to properly operate system) 2. Fuse F1 (8A) on 3-PPS open 3. Batteries connected before AC power energized 4. Battery temperature too high 5. Defective batteries

3-BPS/M Booster Power Supply module

The transmit (TX) and receive (RX) LEDs on the Booster Power Supply Monitor Module should flicker, indicating normal two way communication activity with the CPU.

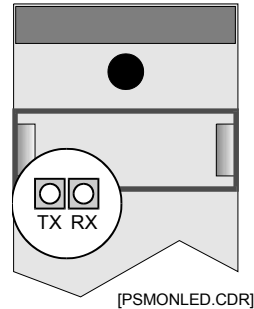

The booster power supply voltages are indicated in Table 8-1. Table 8-3 lists common problems with the booster power supply and booster monitor module.

Table 8-3: Booster Power Supply module troubleshooting

Problem	Possible cause
Supply will not operate from AC line	<ol style="list-style-type: none"> 1. AC line fuse F2 (3.15A slow blow) open 2. Rectified DC fuse F3 (3.15A slow blow) open
RX or TX LED OFF No communication between 3-BPSMON and CPU	<ol style="list-style-type: none"> 1. Defective or poor connection on ribbon cable between 3-BPSMON and 3-BPS 2. 3-BPSMON defective 3. 3-BPS defective
Auxiliary and Rail voltage low	<ol style="list-style-type: none"> 1. Excessive load causing supply to fold back 2. Power Cable between 3-BPSMON and 3-BPS loose or defective 3. Booster Supply failure causing primary supply to fold back
System will not operate on batteries	<ol style="list-style-type: none"> 1. Battery voltage below 18 Vdc. (system automatically turns off when batteries too low to properly operate system) 2. Fuse F1 (8A) on 3-BPS open 3. Batteries connected before AC power energized 4. Battery temperature too high 5. Defective batteries

CPU Central Processor module

The CPU controls all the communication and processing of information for modules located in its cabinet. Token ring

network communication between CPU modules in other cabinets is also processed by the CPU. Network communication is RS-485 when the 3-RS485 card is installed in CPU connector J2, and fiber optic when the 3-FIBMB or 3-NSHM module is connected to J2 of the CPU.

Network and audio data circuits

Figure 8-1 and Table 8-4 show the location and normal state of the communication status LEDs on the CPU module.

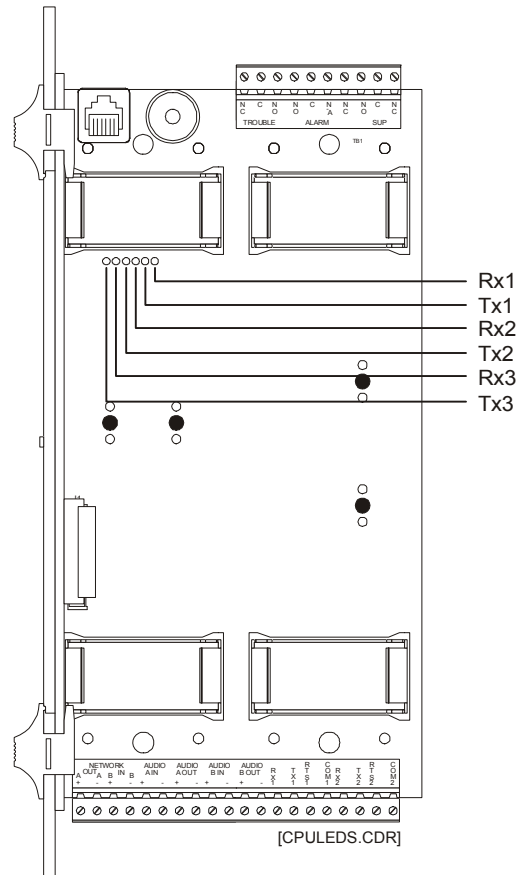

Figure 8-1: CPU module

Table 8-4: CPU LED indications

LED	Normal state	Description
RX1	Flicker	Local Rail Receive Activity
TX1	Flicker	Local Rail Transmit Activity
RX2	Flicker	Network Data Ch A Receive Activity
TX2	Flicker	Network Data Ch A Transmit Activity

RX3	Flicker	Network Data Ch B Receive Activity
TX3	Flicker	Network Data Ch B Transmit Activity

EST3 network wiring alternates between channel A and channel B, as shown in Figure 8-2.

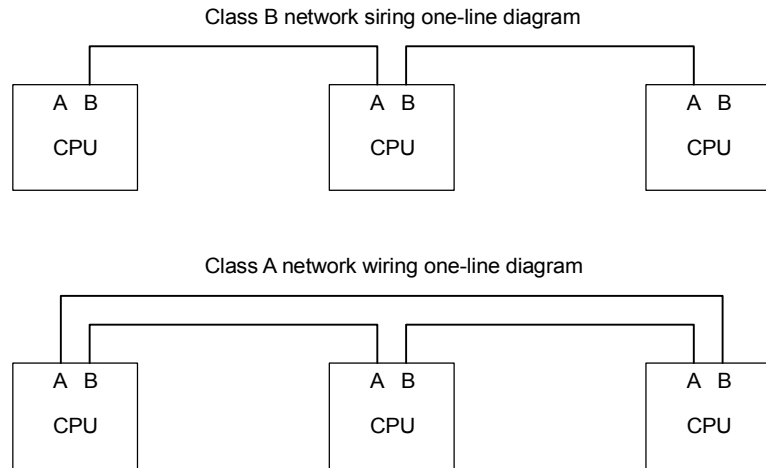

Figure 8-2: Network wiring one-line diagrams

RX1 and TX1 should flicker continuously, indicating normal two-way CPU module to rail module communication activity.

When multiple CPU modules are networked together using Class B wiring, RX2, TX2, RX3, and TX3 on all panels except the first and last should flicker continuously, indicating normal two-way network communication activity on both data channels.

When multiple CPU modules are networked together using Class A wiring, RX2, TX2, RX3, and TX3 should flicker continuously, indicating normal two way network communication activity on data channels A, and B.

The network and audio riser data circuits are isolated at each CPU module. This prevents a shorted data circuit from interrupting communication on the entire circuit. Figure 8-3 shows typical Class B network data circuit.

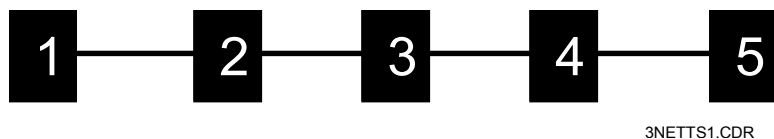

3NETTS1.CDR

Figure 8-3: Class B network data circuit

When trying to isolate trouble on a network or audio data circuit, remember that both shorted and open circuit segments will interrupt communication between two CPU modules.

Figure 8-4 shows an open or short circuit fault between cabinets 3 and 4.

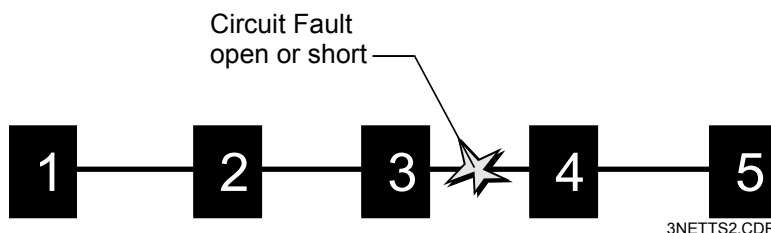

Figure 8-4: Network data circuit fault

Either an open or shorted circuit will interrupt communication between cabinets 3 and 4. The token ring network will reconfigure and operate as two independent sub-networks, one consisting of cabinets 1, 2, and 3; the second consisting of cabinets 4 and 5.

Due to the isolation between cabinets, during a ground fault condition, the number of potential circuits to be investigated is limited to those originating from a single cabinet.

Table 8-5: CPU troubleshooting

Problem	Possible cause
RX1 or TX1 off	<ol style="list-style-type: none"> 1. CPU not firmly seated in rail connectors 2. CPU failure
RX2, TX2 or RX3, TX3 off, or both pairs off	<ol style="list-style-type: none"> 1. (+) and (-) wires reversed. 2. Circuit not properly terminated 3. Network A and Network B circuits crossed 4. Improper wire installed 5. Ground fault 6. 3-RS485 card loose
RS-232 port (J5) inoperative	<ol style="list-style-type: none"> 1. TX and RX wires reversed 2. CPU and peripheral device baud rate mismatched 3. PC improperly configured
Ancillary RS-232 port (TB2-1 to 4 or TB2-5 to 8) inoperative	<ol style="list-style-type: none"> 1. TX and RX wires reversed. 2. CPU and peripheral device baud rate mismatched 3. Peripheral device off-line or improperly configured

Table 8-5: CPU troubleshooting

Problem	Possible cause
RS-485 port (TB2 17 to 20) inoperative	<ol style="list-style-type: none"> 1. (+) and (-) wires reversed. 2. 3-RS485 card not seated properly 3. Network A and Network B circuits crossed 4. Improper wire
Power LED off, no characters on display, switches inoperative	<ol style="list-style-type: none"> 1. No power to panel. 2. Ribbon cable between LCD and CPU loose or defective. 3. CPU defective 4. LCD defective 5. CPU not configured in SDU for LCD
All Module LEDs and switches inoperative AND host module working correctly.	<ol style="list-style-type: none"> 1. Ribbon cable between display and CPU module loose or defective 2. Display not configured in SDU 3. Display defective
Switch activation does not perform the required function.	<ol style="list-style-type: none"> 1. Display not defined in SDU database 2. Domain not configured correctly.

3-FIBMB fiber optic interface

Several models of the 3-FIB card are available to support compatible operations with different models of the CPU.

3-FIB: Compatible with the 3-CPU.

3-FIBA: Compatible with the 3-CPU and 3-CPU1. The 3-FIBA provides Class A audio when used with the 3-CPU1, but not when used with the 3-CPU.

3-FIBMB: Compatible with both the 3-CPU1 and the 3-CPU3, but not with the 3-CPU.

Note: If network communication must be maintained when the node is powered down for service, connect a 12 V battery to J2 on the fiber optic interface card.

The LEDs on the 3-FIBMB interface board adjacent to the fiber optic indicate circuit activity.

Test jumpers

Jumper JP1 is used to put the module in test mode. In the test mode, the “OUT” ports transmit a constant signal, which can be used to measure cable loss.

Table 8-6: 3-FIB troubleshooting

Symptom	Possible causes
No LED activity on any fiber optic port	<ol style="list-style-type: none"> 1. Ribbon cable between interface and electronics card loose, Improperly installed, or broken. 2. Electronics card not properly seated in J2 of CPU.
No LED activity on "IN" fiber optic port	<ol style="list-style-type: none"> 1. Incorrect cable connected to port.
Steady on LED on "IN" fiber optic port	<ol style="list-style-type: none"> 1. Jumper JP1 left in test position.

Signature Controller modules

Please refer to Signature Component Troubleshooting Chapter for complete information on Signature related troubleshooting.

Control / display modules

The information in this section applies to the following models of control / display modules:

3-12/1RY	3-2RY	3-12/2RY
3-12SG	3-12SR	3-12SY
3-12/SIGY	3-12/S1RY	3-12/AS2Y
3-24G	3-24R	3-24Y
3-6/3S3L	3-6/3S1G2Y	3-6/S1GYR

The control / display modules operate independently of the host module on which they are installed. The displays do use the host module's electronics to communicate with the CPU.

The Lamp Test function (pressing Panel Silence and Alarm Silence Switches simultaneously) will quickly isolate hardware problems from programming problems with any display.

Table 8-7: Control / display module troubleshooting

Problem	Possible cause
Module LEDs and switches inoperative AND host module inoperative	<ol style="list-style-type: none"> 1. No power to panel 2. Ribbon cable between display and host module loose or defective 3. Display defective 4. Host module defective

Table 8-7: Control / display module troubleshooting

Problem	Possible cause
All module LEDs and switches inoperative AND host module working correctly	<ol style="list-style-type: none"> 1. Ribbon cable between display and host module loose or defective 2. Display not configured in SDU 3. Display defective
LEDs respond incorrectly	<ol style="list-style-type: none"> 1. Display not defined in SDU database 2. LED misidentified in SDU database 3. Rule governing LED operation not correctly written
Switch activation does not perform the required function	<ol style="list-style-type: none"> 1. Display not defined in SDU database 2. Switch misidentified in SDU database 3. Rule governing switch operation not correctly written

Audio amplifier modules

Table 8-8: 3-ZAxx Zoned Audio Amplifier module troubleshooting

Problem	Possible cause
Audio output level too low	<ol style="list-style-type: none"> 1. Jumpers set for 25 Vrms when connected to a 70 Vrms circuit 2. Gain adjusted too low 3. Input level to ASU too low
No or extremely low audio output	<ol style="list-style-type: none"> 1. Fuse blown 2. Gain set too low
Audio level too high	<ol style="list-style-type: none"> 1. Jumper set for 70 Vrms when connected to 25 Vrms circuit 2. Gain adjusted too high 3. Input level to ASU too high
Amplifier current limiting	<ol style="list-style-type: none"> 1. Audio circuit overloaded 2. Input level to ASU too high
Incorrect amplifier version reported to CPU module	<ol style="list-style-type: none"> 1. Jumpers installed incorrectly

3-OPS Off-Premises Signal module

Table 8-9: 3-OPS Off-Premises Signal module troubleshooting

Problem	Possible cause
Module in trouble	<ol style="list-style-type: none"> 1. Master box circuit open or not reset 2. Reverse polarity circuit open 3. 3.6 kΩ EOL resistor not installed on unused circuits
Remote receiver indicates circuit trouble and does not receive alarm	<ol style="list-style-type: none"> 1. Circuit polarity reversed 2. Circuit open 3. Excessive circuit resistance 4. Incompatible receiver 5. Defective module
Remote receiver does NOT indicate circuit trouble and does not receive alarm	<ol style="list-style-type: none"> 1. 3-OPS Not activated by panel (SDU database) 2. Incompatible receiver 3. Defective module

3-IDC8/4 Initiating Device Circuit module

Table 8-10: 3-IDC8/4 Initiating Device Circuit module troubleshooting

Problem	Possible cause
Module in trouble	<ol style="list-style-type: none"> 1. 4.7 kΩ EOL resistor not installed on unused IDC circuits 2. 15 kΩ EOL resistor not installed on unused NAC circuits 3. No communication with CPU module 4. Module not defined in SDU database. 5. Field wiring connector not plugged into module
NAC output not working	<ol style="list-style-type: none"> 1. Jumpers installed incorrectly 2. External source configured but not connected 3. Circuit folding back due to overload. 4. Circuit "Silenced" 5. Circuit shorted 6. Polarized device defective or reversed on circuit
IDC circuit not working	<ol style="list-style-type: none"> 1. Incompatible 2-wire smoke detectors 2. Excessive wiring resistance or capacitance

3-LDSM Display Support module

Table 8-11: 3-LDSM Display Support module troubleshooting

Problem	Possible cause
All Module LEDs and switches inoperative <i>and</i> host module working correctly	<ol style="list-style-type: none"> 1. Ribbon cable between display and 3-LDSM module loose or defective 2. Module not configured in SDU 3. Display not configured in SDU 4. Display defective

3-MODCOM(P) Modem Communicator module

Diagnostic aids

Two LEDs (DS1 and DS2) provide diagnostic information. The activity of DS1 and DS2 during dialing and data transmission are outlined in the following table.

Table 8-12: 3-MODCOM LED states and meanings

LED state	DS1 meaning	DS2 meaning
Off	No activity	No activity
On	Line 1 has been seized	Line 2 has been seized
Slow flash	Dialer or modem data is being passed on Line 1	Dialer data is being passed on line 2. (Modem data is passed only on line 1.)
Slow flash (both)	Slow flash on both LEDs indicates an ongoing download of application code or configuration code from CPU or SDU	
Fast flash	Reflects ringing on Line 1. (Flashing follows pattern detected.)	N/A - line 2 does not have ring detection

A Radio Shack Mini Audio Amplifier (catalog number 277-1008) facilitates listening to the distinctive sounds associated with dialing, receiving handshakes, transmitting data, and receiving acknowledgements. Obtain this device locally and place a 0.1 μ F 200 V or greater capacitor in series with one of the leads. (You can install the capacitor permanently, within the case, if you prefer.) Alternately, you can use a lineman's butt set in monitor mode.

During downloading from a remote computer, you will hear the distinct sound of modems establishing a connection, then a series

of rapid chirps as data is transmitted from the ACDB or KDC program.

Note: Remove the amplifier when you finish troubleshooting. Do not install the amplifier permanently.

Common causes of problems

Evaluation of visual and audible indications will usually serve to isolate the source of trouble. Before attempting to replace the 3-MODCOM module, the following causes of problems should be investigated:

- The 3-MODCOM module is not properly seated on the rail connectors, or one or more connector pins have been bent away from the associated sockets
- A modular telephone plug is not connected to the appropriate line 1 or line 2 jack, or is not fully seated, or is not connected at the telephone block
- The 3-MODCOM has been configured with incorrect CMS telephone numbers
- The telephone line is faulty

If the module and telephone line are okay, check the CMS telephone number by dialing it using a standard telephone plugged directly into the RJ-31X jack. (The jack will accommodate a standard modular phone plug.)

You should hear a dial tone when going off-hook, lose the dial tone after dialing the first digit, hear the receiver ringing, hear the CMS receiver go off-hook and send a handshake tone.

Typical problems dialing the CMS involve missing or incorrect area codes, the need to dial 1 for long distance, and missing line access codes (example: dialing 9 for an outside line).

If the receiver answers, check that it is sending out the correct handshake. For SIA P2 (3/1 pulse), SIA P3 (4/2 pulse), and SIA DCS the receiver should send a single tone of 0.5 to 1.0 seconds in duration. For Contact ID, the handshake signal consists of two short tones of different frequency. For TAP there should be a modem-type exchange of handshake messages.

If the receiver sends the correct handshake and the 3-MODCOM transmits data but the receiver does not send an acknowledgement, check that the receiver is compatible with the desired protocol. (SIA DCS, P2, and P3 standards are available from the Security Industry Association). Typical problems involve an incompatible format or data message.

If the handshake and acknowledge signals are audible, check that the correct account number was configured in the 3-MODCOM

and that the code being sent was correctly programmed in the CMS computer.

Where a 3-MODCOM module is suspected of being faulty, try substituting a known good one that has been properly programmed.

Audio components

3-ASU Audio Source Unit

Table 8-13: 3-ASU Audio Source Unit Troubleshooting

Problem	Possible cause
Unit does not respond. No network RX or TX LED activity	<ol style="list-style-type: none"> 1. Power or data connectors loose or connected wrong on Rail Chassis Interface Card 2. Ribbon cable between Rail Chassis Interface Card and 3-ASU (and 3-FTCU, if installed) loose or defective 3. Ribbon cable between 3-ASU main board and cover loose or defective
No <i>All Call</i> page audio output from network amplifiers and low level page output terminals	<ol style="list-style-type: none"> 1. Defective microphone 2. Page inhibit timer set too long 3. Defective 3-ASU 4. Ribbon cable between 3-ASU main board and cover loose or defective 5. Defective amplifier
No <i>All Call</i> page audio output from network amplifiers, output available at low level page output terminals	<ol style="list-style-type: none"> 1. Network audio data riser open, shorted, or incorrectly wired 2. Network data riser open, shorted, or incorrectly wired 3. TB2 on the CPU loose or incorrectly wired 4. 3-ASU not properly configured in SDU database 5. Amplifiers not properly installed or defective
Page audio distorted	<ol style="list-style-type: none"> 1. Speaking too loud into microphone. Speak such that the last green LED on the page level meter only flickers occasionally 2. Gain of individual amplifiers set too high
Auxiliary Input volume level too low	<ol style="list-style-type: none"> 1. Adjust Aux input gain control on ASU 2. Auxiliary input wiring open or shorted
Auxiliary Input volume level too high	<ol style="list-style-type: none"> 1. Adjust Aux input gain control on ASU
Recorded messages not working properly	<ol style="list-style-type: none"> 1. 3-ASUMX memory not firmly seated in connector 2. Audio database not correctly downloaded into 3-ASU 3. Incorrect message label referenced.
Wrong messages going to wrong floors	<ol style="list-style-type: none"> 1. Amplifier and message labels and rules incorrect or mislabeled
Telephone Page inoperative	<ol style="list-style-type: none"> 1. Wiring between 3-ASU and 3-FTCU open, shorted, or incorrectly wired

Table 8-13: 3-ASU Audio Source Unit Troubleshooting

Problem	Possible cause
Remote Microphone trouble	<ol style="list-style-type: none"> 1. Wrong or missing EOL resistor on microphone key input 2. No supervisory tone on DC current on remote microphone audio output

3-FTCU Firefighter Telephone Control Unit

Table 8-14: 3-FTCU (3-ASU/FT) Firefighter Telephone Control Unit Troubleshooting

Problem	Possible cause
Unit does not respond No RX or TX LED activity	<ol style="list-style-type: none"> 1. Power or data connectors loose or connected wrong on Rail Chassis Interface Card 2. Ribbon cable between Rail Chassis Interface Card and 3-FTCU loose or defective 3. Ribbon cable between 3-FTCU main board and cover loose or defective 4. Defective 3-FTCU
Signature modules do not switch telephones correctly	<ol style="list-style-type: none"> 1. Network data riser open, shorted, or wired incorrectly 2. TB2 on the CPU loose or wired incorrectly 3. Defective 3-FTCU 4. Signature module has incorrect label, personality code, or device type 5. Defective Signature module
Low telephone volume level	<ol style="list-style-type: none"> 1. More than five handsets active at one time 2. Phone riser open, shorted, or wired incorrectly 3. Connector TB1 on 3-FTCU loose 4. Defective telephone
Call displayed by LCD doesn't match connected call	<ol style="list-style-type: none"> 1. Signature module incorrectly labeled in rule 2. Signature module misidentified or installed in wrong location

SIGA audio amplifiers

The following material refers to these amplifier models:

- SIGA-AA30 Audio Amplifier
- SIGA-AA50 Audio Amplifier

Note: ~~At publication time, these modules were not approved for use in UL 864 9th edition applications. Call Technical Support to determine the current approval status of the modules.~~

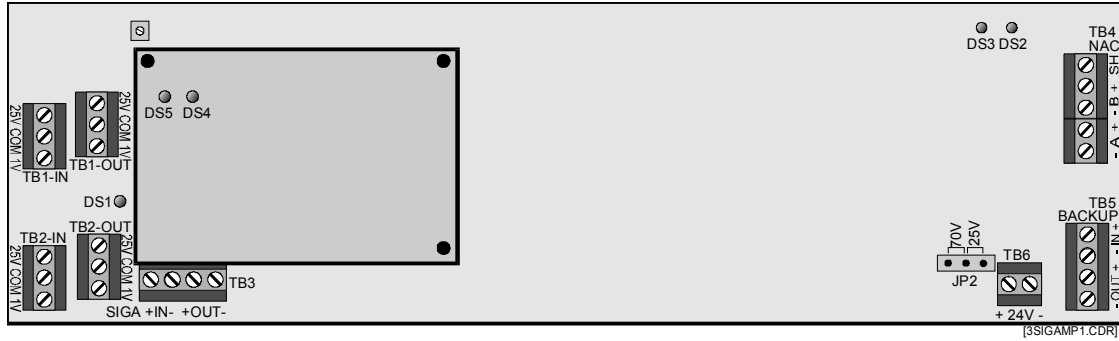

Table 8-15: SIGA-AAxx LED indications

LED	Color	Description
DS1	Yellow	Power Amp Enabled
DS2	Yellow	Backup Mode
DS3	Green	Amplifier Active
DS4 (daughter board)	Green (flashing)	Normal
DS5 (daughter board)	Red (flashing)	Active Condition

Gain adjustment

With the amplifier connected to the speaker load, use the gain adjust potentiometer (R116) to get a 25 Vrms or 70 Vrms signal (depending on JP2 setting) with a 1Vrms 1 kHz tone at the amplifier input. If an oscilloscope is used to adjust levels, use the following peak-to-peak voltage levels:

- 25 Vrms = 71 V_{PP}
- 70 Vrms = 200 V_{PP}

The amplifier must be connected to a load to properly adjust the gain. In the event the actual speaker circuit can not be used, a dummy load must be fabricated according to Table 8-16. The wattage rating of the dummy load must exceed the output power rating of the amplifier.

Table 8-16: Amplifier dummy load values

Output power	25 Vrms output	70 Vrms output
30 Watts	20.8 Ω @ 30W	167Ω @ 30W
50 Watts	12.5 Ω @ 50W	100Ω @ 50W

To maintain DC supervision and keep the amplifier out of trouble while adjusting the gain, connect a 47 kΩ EOL resistor

across the NAC B output (TB4-2 and TB4-3), then connect the dummy load to the NAC A Output terminals (TB4-4 and TB4-5).

Caution: Do not operate the amplifier with both the speaker circuit and the dummy load connected.

Table 8-17: SIGA-AAxx Audio Amplifier troubleshooting

Problem	Possible cause
No output	<ol style="list-style-type: none"> 1. 24 Vdc power or input signal missing 2. Output circuits wired incorrectly 3. Daughter board not firmly seated in connector 4. Module defined incorrectly in database 5. In backup mode with backup amplifier or wiring problem 6. Branch circuit control modules inoperative or programmed incorrectly
Backup 1 kHz Tone sounding	<ol style="list-style-type: none"> 1. Input wiring incorrect or missing 2. Low or no audio input
Low Output	<ol style="list-style-type: none"> 1. 70 Vrms speakers with 25 Vrms jumper setting 2. Too many SIGA-CC1s or SIGA-CC2s installed causing amplifier to shut down 3. Gain (R116) setting too low

Pseudo point descriptions

Table 8-18: System pseudo points

Address	Label	Source	Functional description
0001	Startup Response	CPU	Changes to the active state when the panel is energized or an operator initiates a Restart from the LCD module.
0002	First Alarm Response	CPU	Changes to the active state when the first point on a panel or any panel in the same network routing group changes to the alarm state.
0003	First Supervisory Response	CPU	Changes to the active state when the first point on a panel or any panel in the same network routing group changes to the supervisory state.
0004	First Trouble Response	CPU	Changes to the active state when the first point on a panel or any panel in the same network routing group changes to the trouble state.
0005	First Monitor Response	CPU	Changes to the active state when the first point on a panel or any panel in the same network routing group changes to the monitor state.
0006	Evacuation Response	CPU	Changes to the active state when an operator presses a switch that executes the Evacuation command.
0007	Drill Response	CPU	Pseudo point that changes to the active state when an operator presses a switch that executes the Drill command.
0008	AllCall Response	CPU	Changes to the active state when an operator presses the All Call or All Call Minus switch on the 3-ASU.
0009	Alarm Silence Response	CPU	Changes to the active state when an operator presses a switch that executes the AlarmSilence command.
0010	Two Stage Timer Expiration	CPU	Changes to the active state when a panel's two-stage alarm timer expires.
0011	Reset Active	CPU	Changes to the active state when an operator presses a switch that executes the Reset command.
0012	Reset Phase 1	CPU	Changes to the active state when the first phase of the 3-phase reset cycle starts.
0013	Reset Phase 2	CPU	Changes to the active state when the second phase of the 3-phase reset cycle starts.

Table 8-18: System pseudo points

Address	Label	Source	Functional description
0014	Reset Phase 3	CPU	Changes to the active state when the third phase of the 3-phase reset cycle starts.
0015	First Disable Response	CPU	Changes to the active state when the first point on a panel or any panel in the same network routing group changes to the disable state.
0016	Fail Safe Event	CPU	Changes to the active state when a device asserts the rail alarm-not line and the CPU module has not registered an alarm event.
0017	Service Group Active	CPU	Changes to the active state when an operator enables a Service Group from the LCD module.
0018	Two Stage Timer Active	CPU	Changes to the active state when a panel's two-stage alarm timer starts.
0019	Loop Controller Reset Extension	CPU	Changes to the active state when a loop controller stays in the reset mode longer than expected.
0020	Service Device Supervision	CPU	Changes to the active state when an operator cancels a Service Group test while a circuit under test remained active.
0021	User Trouble	CPU	Changes to the active state when an operator forces a trouble into the system. Not implemented at this time.
0022	Ext Database Incompatibility	CPU	Changes to the active state when a different database in one or more network nodes
0023	Reboot Fault	CPU	Changes to the active state when the CPU module is interrupted unexpectedly.
0101– 0164	Comm Fail xx	CPU	Changes to the active state when the CPU is unable communicate with the networked CPU module in cabinet xx.
0200– 0222	Task xx Watchdog Violation	CPU	Changes to the active state when task xx fails to execute properly.
0261– 0279	Configuration Mismatch Card xx.	CPU	Changes to the active state when the card in slot xx can not perform the programmed advance feature (currently only degraded mode).
0281– 0299	DB Out Of Sync with CPU Card xx	CPU	Changes to the active state when the Signature controller module in rail slot xx reports an actual and expected data mismatch.

Table 8-19: Local alarm pseudo points

Address	Label	Source	Description
0676	Unprogrammed Device	3-AADC1	Device not defined in SDU database is in alarm or trouble state
0676	Unprogrammed Device Data Card 1	3-DSDC 3-SSDC1 3-SDDC1	Device not defined in SDU database is in alarm or trouble state
0686	Unprogrammed Device Data Card 2	3-DSDC 3-SSDC1 3-SDDC1	Device not defined in SDU database is in alarm or trouble state

Table 8-20: Local trouble pseudo points

Address	Label	Source	Description
0001	Class A Fault Spur	3-SAC	Fault or break in Class A loop on SAC bus
0002	Class A Fault Video Bus	3-SAC	Fault or break in Class A loop on video bus
0003	Annunciator Supervision	3-SAC	Control / display module faulty or missing or not properly configured
0004	Rail Module Communication Fault	3-SAC	Cabinet local rail communication failure
0005	Video Communication Fault	3-SAC	Fault or break in video signal lines
0006	RAM Fault or Stack Fault	3-SAC	Fault in internal 3-SAC processor
0007	Code Supervision	3-SAC	Executable program corrupt
0008	Internal Fault	3-SAC	3-SAC hardware failure
0009	Configuration Fault	3-SAC	1. Module in wrong slot 2. Incorrect display on module
0010	Database Supervision	3-SAC	Database corrupt
0071	Task Failure	3-SAC	
0071	Waiting for SDU Download	3-SAC	Database download from the SDU is in progress or was incomplete
0600	Annunciator Supervision	General	Control / display module faulty or missing or not properly configured
0601	Class A Failure	CPU	Fault or break in Class A network data riser connection
0601	Rail Module Communication Fault	General	Cabinet local rail communication failure
0602	Ground Fault Detection	CPU	Any cabinet component or field wiring
0603	Audio Supervision	CPU	Audio data circuit open or shorted

Table 8-20: Local trouble pseudo points

Address	Label	Source	Description
0604	Internal Fault	General	CPU hardware failure
0604	RAM Fault or Stack Fault	3-AADC1	RAM or Stack (memory) fails its interval check
0605	Database Supervision	General	Database corrupt
0605	DB Supervision Audio Default Tone	3-ASU	No message present, problem erasing flash, message space fails internal checks
0606	Code Supervision	General	Executable program corrupt
0607	Auxiliary Port One	CPU	Port 1 serial communication circuit open or shorted
0607	Data Card Fault	3-AADC1	N/A
0607	Data Card Fault 1	3-DSDC 3-SSDC1 3-SDDC1	N/A
0608	Auxiliary Port Two	CPU	Port 2 serial communication circuit open or shorted
0608	Data Card Fault 2	3-DSDC 3-SSDC1 3-SDDC1	N/A
0609	Panel in Download Mode	CPU	Panel out of service. In mode to accept download data
0609	Configuration Fault	General	1. Module in wrong slot 2. Incorrect display on module
0610	Network Audio Circuit A Fault	CPU	Loss of signal on primary audio connection
0610	Rail Voltage Out of Spec	3-PPS/M 3-BPS/M 3-BBC/M	1. Rail voltage >30 Vdc or <24 Vdc 2. Excessive rail current load 3. Faulty or misadjusted 3-PPS/3-BPS
0610	Telephone Line 1	3-MODCOM	Line-cut fault detected on phone line 1
0611	Network Audio Circuit B Fault	CPU	Loss of signal on secondary audio connection
0611	Rail Vltg Blw Batt	3-PS/M	Excessive rail current load
0611	Telephone Line 2	3-MODCOM	Line-cut fault detected on phone line 2
0612	Heat Sink Too Hot	3-PPS/M 3-BPS/M 3-BBC/M	1. Enclosure vents clogged 2. Heat sink not fastened properly

Table 8-20: Local trouble pseudo points

Address	Label	Source	Description
0612	Receiver Test - Line 1	3-MODCOM	Line 1 test transmission to CMS failed
0613	Lo Batt Cut Off	3-PPS/M 3-BPS/M 3-BBC/M	Battery voltage below 19.5 Vdc when on battery backup
0613	Receiver Test - Line 2	3-MODCOM	Line 2 test transmission to CMS failed
0614	AC Brownout	3-PPS/M 3-BPS/M 3-BBC/M	AC line voltage below 96 Vac for 3-PPS or 196 Vac for 3-PPS/230
0614	RS-232 Channel	3-MODCOM	Communication failure with RS-232 card on module
0615	Batt Trbl	3-PPS/M 3-BPS/M 3-BBC/M	1. Battery wiring open 2. Battery voltage below 24 Vdc 3. Battery internal resistance too high (load test failure)
0616	Network_ClassA_CircuitA_Failure_01_01	CPU	CPU unable to receive data on data riser circuit A
0617	Network_ClassA_CircuitB_Failure_01_01	CPU	CPU unable to receive data on data riser circuit B
0616	Aux Pwr Ovid Ckt 2	3-PPS/M 3-BPS/M 3-BBC/M	1. Excessive load 2. Circuit shorted
0617	DSP Supervision	3-MODCOM	The DSP chip on the module failed.
0617	Pwr Supply Fail	3-PPS/M 3-BPS/M 3-BBC/M	1. Cables between power supply and monitor module loose or missing 2. Defective power supply or monitor module
0618	Aux Pwr Ovid Ckt 1	3-PPS/M 3-BPS/M 3-BBC/M	1. Excessive load 2. Circuit shorted
0619	Drvr Pwr Supply Fail	3-PPS/M 3-BPS/M 3-BBC/M	1. Cables between power supply and monitor module loose or missing 2. Defective power supply or monitor module
0620	Demux Audio Input	3-ZAxx	Digitized audio data missing
0620	Waiting for SDU Download	3-MODCOM	Database download from the SDU is in progress or was incomplete

Table 8-20: Local trouble pseudo points

Address	Label	Source	Description
0621	Amp Overcurrent	3-ZAxx	1. Circuit shorted 2. Speaker wattage tap setting exceeds output rating of amplifier 3. 70 Vrms jumper setting used with 25 Vrms speakers. .
0622	Primary Audio Output DC	3-ZAxx	1. Open DC NAC circuit, missing or wrong value EOL resistor 2. Shorted DC NAC circuit
0623	Primary Audio Output Analog	3-ZAxx	1. Open Audio NAC circuit, missing or wrong value EOL resistor 2. Shorted Audio NAC circuit 3. Output voltage jumper set wrong
0624	Backup Audio Output Analog	3-ZAxx	1. Open Audio NAC circuit, missing or wrong value EOL resistor 2. Shorted Audio NAC circuit 3. Output voltage jumper set wrong
0625	Amplifier Daughter Board	3-ZAxx	Defective board
0626	Fuse Supervision	3-ZAxx	Open fuse in amplifier
0627	PAL Supervision	3-ZAxx	Bad PAL chip. Replace amplifier.
0629	Request Backup	3-ZAxx	N/A
0630	Riser Supervision	3-FTCU	1. Open circuit, missing or wrong value EOL resistor 2. Shorted circuit
0631	User Interface	3-FTCU	Ribbon cable between display and main PC board loose or missing.
0632	Master Phone Supervision	3-FTCU	Master handset internal wiring fault
0633	Handset Off Hook	3-FTCU	Hook switch defective
0640	Jumper Fault	3-OPS	Jumpers incorrectly set
0641	AtoD Converter Failure	3-OPS	Internal module failure
0642	City Tie Open	3-OPS	N/A
0652	Input Supervision Trbls	3-ASU	Defective microphone or connections
0653	Phone Page Time Out	3-ASU	Phone page switch has been activated for a period which exceeds the time limit set via SDU program
0654	Audio Hardware Mismatch	3-ASU	Mismatch between 3-ASUMX specified via SDU program and that installed in the 3-ASU

Table 8-20: Local trouble pseudo points

Address	Label	Source	Description
0655	RAM Diagnostic Failure	3-ASU	Memory failure in 3-ASU
0656	Audio Default Failure	3-ASU	1. 3-ASUMX memory card missing 2. Audio database does not exist
0658	Audio Interface Failure	3-ASU	3-ASU hardware fault
0659	Audio Class Supervision	3-ASU	One riser open or shorted
0670	In Bootloader	3-AADC1	PC connected to card attempting download
0670	In Bootloader	3-DSDC 3-SSDC1 3-SDDC1	PC connected to card attempting download
0671	Line Opened or Shorted	3-AADC1	Wiring Fault
0671	Line Opened or Shorted Data Card 1	3-DSDC 3-SSDC1 3-SDDC1	Wiring Fault
0672	Map Fault Data Card 1	3-DSDC 3-SSDC1 3-SDDC1	1. Mismatch between actual data and expected data 2. Defective wiring 3. Defective device
0677	Grnd Fault	3-AADC1	Wiring Fault
0677	Grnd Fault Data Card 1	3-DSDC 3-SSDC1 3-SDDC1	Wiring Fault
0678	Reconstct Line	3-AADC1	N/A
0679	Smoke Power Current Limit	3-AADC1	N/A
0679	Smoke Power Current Limit Card 1	3-DSDC 3-SSDC1 3-SDDC1	N/A
0680	Internal Failure	3-LDSM	N/A
0681	Line Opened or Shorted Data Card 2	3-DSDC 3-SSDC1 3-SDDC1	Wiring Fault
0682	Map Fault Data Card 2	3-DSDC 3-SSDC1 3-SDDC1	1. Mismatch between actual data and expected data 2. Defective wiring 3. Defective device
0687	Grnd Fault Data Card 2	3-DSDC 3-SSDC1 3-SDDC1	Wiring Fault

Table 8-20: Local trouble pseudo points

Address	Label	Source	Description
0689	Smoke Power Current Limit Card 2	3-DSDC 3-SSDC1 3-SDDC1	Defective module
0690	Configuration Mismatch Slot 1	3-DSDC 3-SSDC1 3-SDDC1	N/A

Table 8-21: Local monitor pseudo points

Address	Label	Source	Description
0615	Incoming Ring	3-MODCOM	An incoming call was received by the module.
0622	Outgoing Call in Progress		Dialer is active
0650	All Call Active	3-ASU	Changes to the active state when an operator presses the All Call switch
0651	Mic Key Active	3-ASU	Changes to the active state when an operator presses the push-to-talk switch on the paging microphone.
0673	Mapping In Progress Data Card 1	3-DSDC 3-SSDC1 3-SDDC1	N/A
0674	Mapping Disbld Data Card 1	3-DSDC 3-SSDC1 3-SDDC1	Mapping manually disabled
0675	Device Maint Alert	3-AADC1	N/A
0675	Device Maint Alert Data Card 1	3-DSDC 3-SSDC1 3-SDDC1	Dirty detector on loop 1
0678	Reconstct Line Data Card 1	3-DSDC 3-SSDC1 3-SDDC1	N/A
0683	Mapping In Progress Data Card 2	3-DSDC 3-SSDC1 3-SDDC1	N/A
0684	Mapping Disbld Data Card 2	3-DSDC 3-SSDC1 3-SDDC1	Mapping manually disabled
0685	Device Maint Alert Data Card 2	3-DSDC 3-SSDC1 3-SDDC1	Dirty detector on loop 2

Table 8-21: Local monitor pseudo points

Address	Label	Source	Description
0688	Reconstct Line Data Card 2	3-DSDC 3-SDDC1 3-SDDC1	N/A

Table 8-22: Nonsupervised output pseudo points

Address	Label	Source	Description
0621	Manual Answer Control	3-MODCOM	Answers incoming call

Table 8-23: CRC pseudo points

Address	Label	Event type	Description
SS01	AC Brownout	Access trouble	Sustained low voltage from CRC supply to device
SS02	Low Battery	Access trouble	CRC battery below specified voltage
SS03	Tamper	Security alarm	CRC tamper switch was activated
SS04	Strike Fault	Access trouble	Strike device failed
SS05	Reader Fault	Access trouble	Card reader failed
SS06	RAM Fault or Stack Fault	Access trouble	CRC processor failed
SS07	Code Supervision	Access trouble	CRC executable program corrupt
SS08	Database Supervision	Access trouble	CRC database corrupt
SS09	Communications Fault	Access trouble	CRC lost communication with 3-SAC
SS10	Loop 1	Security alarm (configurable)	Input device on loop 1 activated
SS11	Loop 2	Security alarm (configurable)	Input device on loop 2 activated
SS12	Task Failure	Local trouble	Changes to the active state when a task fails to execute properly
SS15	Waiting for SDU Download	Local trouble	Database download from the SDU is in progress or was incomplete
SS32	CRC Strike Timed	Access output	Activate the strike device for a specified interval
SS33	CRC Strike Unlock	Access output	Activate the strike device
SS34	CRC Relay Timed	Access output	Activate the CRC relay for a specified interval

Table 8-23: CRC pseudo points

Address	Label	Event type	Description
SS35	CRC Relay Open	Access output	Activate the CRC relay
SS36	CRC Inside Reader Disable	Access output	Disable the inside card reader device (for load shedding)
SS37	CRC Outside Reader Disable	Access output	Disable the outside card reader device (for load shedding)
SS38	CRC Sounder	Access trouble	CRC sounder base trouble

SS represents the CRC device number, as configured in the SDU.

Table 8-24: KPDISP pseudo points

Address	Label	Event type	Description
SS06	RAM Fault or Stack Fault	Local trouble	KPDISP processor failed
SS07	Code Supervision	Local trouble	KPDISP executable program corrupt
SS08	Database Supervision	Local trouble	KPDISP database corrupt
SS09	Communications Fault	Local trouble	KPDISP lost communication with 3-SAC
SS12	Task Supervision	Local trouble	Changes to the active state when a task fails to execute properly
SS13	Waiting for Download	Local trouble	Database download from the SDU is in progress or was incomplete
SS14	User Record Supervision	Local trouble	N/A
SS15	Controller Communication Fault	Local trouble	KPDISP lost communication with 3-SAC (displayed on KPDISP only)
SS16	Panel Communication Fault	Local trouble	KPDISP lost communication with panel (displayed on KPDISP only)
SS32	Entry Buzzer	Nonsupervised output	Activates for configured time to allow the partition to be disarmed before going into alarm
SS33	Exit Buzzer	Nonsupervised output	Activates for configured time to allow the person arming a partition to exit before signaling any alarm events

SS represents the KPDISP device number, as configured in the SDU.

Table 8-25: Local relay pseudo points

Address	Label	Source	Description
0002	Amplifier Backup	3-ZAxx	Changes to the active state when the amplifier's input relay selects the back up amplifier input as its signal source.
0003	Channel_1_Relay_Confirmation	3-ZAxx	Changes to the active state when the amplifier's input relay selects channel 1.
0004	Channel_2_Relay_Confirmation	3-ZAxx	Changes to the active state when the amplifier's input relay selects channel 2.
0005	Channel_3_Relay_Confirmation	3-ZAxx	Changes to the active state when the amplifier's input relay selects channel 3.
0006	Channel_4_Relay_Confirmation	3-ZAxx	Changes to the active state when the amplifier's input relay selects channel 4.
0007	Channel_5_Relay_Confirmation	3-ZAxx	Changes to the active state when the amplifier's input relay selects channel 5.
0008	Channel_6_Relay_Confirmation	3-ZAxx	Changes to the active state when the amplifier's input relay selects channel 6.
0009	Channel_7_Relay_Confirmation	3-ZAxx	Changes to the active state when the amplifier's input relay selects channel 7.
0010	Channel_8_Relay_Confirmation	3-ZAxx	Changes to the active state when the amplifier's input relay selects channel 8.
0011	Page Select	3-ZAxx	Changes to the active state when the amplifier's input relay selects the Page channel.

Signature data circuit (SDC) operation

The advanced features of the Signature controller module perform a number of advanced operations. These operations are not always apparent from the panel controller. Table 8-26 lists a number of SDC conditions and describes the circuit's operation.

Table 8-26: SDC operation

Condition	Operation
Remove a detector, then re-install the same detector in the same base.	<ol style="list-style-type: none"> 1. The system displays a trouble with the detector's label or address when the detector is removed. 2. The system restores completely when the detector is re-installed in its original base.
Remove a module or pull station, then re-install the same device in the same location.	<ol style="list-style-type: none"> 1. The system displays a trouble with the module's label or address when the device is disconnected. 2. The panel restores completely when the device is re-installed in its original location.
Remove a detector, then re-install a different detector of the same type in the same base.	<ol style="list-style-type: none"> 1. The system displays a trouble with the detector's label or address when the detector is removed 2. When the new detector is installed, the Signature controller module re-maps the circuit, replacing the S/N of the old detector with the S/N of the new detector. All the old detector's sensitivity and verification settings are transferred to the new detector. The system will return to normal when mapping is finished.
Remove a module or pull station, then re-install a different device of the same type in the same location. (SIGA-UM replacement modules must have jumper JP1 set in the same position as the original module.)	<ol style="list-style-type: none"> 1. The system displays a trouble with the device's label or address when the device is disconnected. 2. When the new device is installed, the Signature controller module re-maps the circuit, replacing the S/N of the old device with the S/N of the new device. If the devices are modules (not pull stations), the old module's personality codes are transferred to the new module. The panel will return to normal when mapping is finished.
Remove a detector, then re-install a different type detector in the same base.	<ol style="list-style-type: none"> 1. The system displays a trouble with the detector's label or address when the detector is removed. 2. When the new detector is installed, the Signature controller module re-maps the circuit, replacing the S/N of the old detector with the S/N of the new detector. All the old detector's sensitivity and verification settings (when applicable) are transferred to the new detector. The new detector will be operational, however the panel will be in trouble, indicating a device type mismatch. The System Definition Utility program must be used to re-assign the device type to get the system out of trouble.

Table 8-26: SDC operation

Condition	Operation
Remove a module or pull station, then re-install a different type module or pull station in the same location.	<ol style="list-style-type: none"><li data-bbox="570 300 1336 357">1. The system displays a trouble at the device's label or address when the device is removed.<li data-bbox="570 373 1336 590">2. When the new device is installed, the Signature controller module re-maps the circuit, replacing the S/N of the old device with the S/N of the new device. The new module is NOT operational. The panel will be in trouble, indicating a device type mismatch. System Definition Utility program must be used to re-assign the device type to get the panel out of trouble.<li data-bbox="570 606 1336 703">3. If a single address module is replaced with a dual address module or vice versa, a map fault will be generated by the address count mismatch.

Basic Signature data circuit troubleshooting

Isolating circuit and device problems

The process of isolating a problem on a Signature data circuit is similar to that used on a conventional fire alarm Initiating Device Circuit (IDC). An accurate and complete wiring diagram of the data circuit installation is the best troubleshooting aid available. When used in conjunction with the information provided by the control panel, you should be able to easily isolate open conditions or defective devices. The data circuit shown in Figure 8-5 will be used to illustrate basic troubleshooting techniques.

When troubleshooting Class A circuits, disconnect the circuit from the return (SIGA/A) terminals, and temporarily jumper both SIGA/A terminals to the respective SIGA/B terminals. Then troubleshoot the circuit as a Class B circuit.

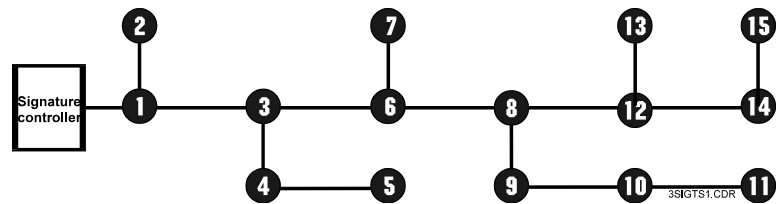

Figure 8-5: Normal circuit topology

Open circuit conditions

On a circuit with an open fault, the Signature modules will be communicating with devices up to the break. The LCD module will indicate a trouble condition on all devices beyond the break. This is illustrated in Figure 8-6 where devices 1 through 7 continue to operate while devices 8 through 15 report device troubles.

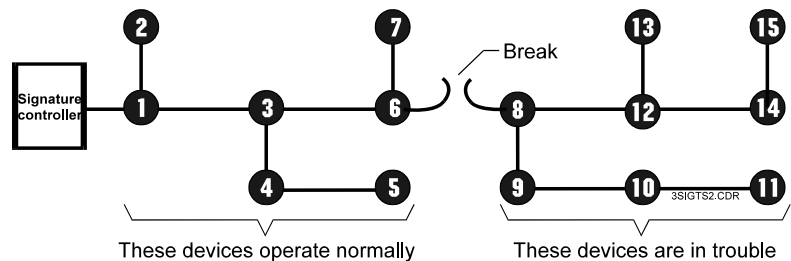

Figure 8-6: Break in circuit between devices 6 and 8

Referring again to Figure 8-6, a wire break or intermittent connection between devices 6 and 8 is the most probable cause

of the failure. Other possible but unlikely causes with the same symptoms include device failure of only devices 9 -15; and devices 9-15 not loaded in the Signature module’s database or not properly configured using the Signature portion of the data entry program.

Short circuit conditions

Short circuit conditions require selective isolation of portions of the data circuit to systematically narrow down the fault’s location. A shorted circuit will typically show a trouble condition on all devices, as illustrated in Figure 8-7.

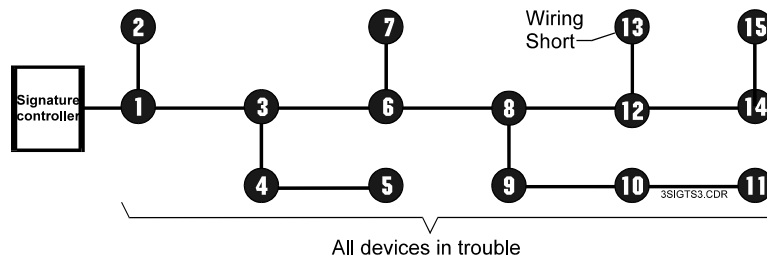

Figure 8-7: Wiring Short On device 13

To isolate the short, open the circuit at a location that will disconnect approximately 50% of the installed devices, as shown in Figure 8-8.

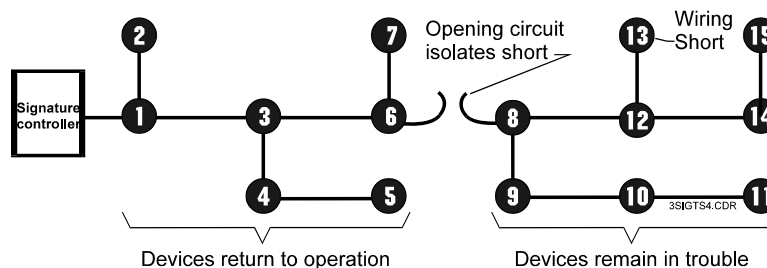

Figure 8-8: Isolating circuit short

If some of the devices restore in Figure 8-8, the short is located on the portion of the circuit that has been disconnected. If no devices restore when the circuit is opened, the short has been isolated to the first 50% of the circuit.

Re-connect the previously isolated portion of the circuit, and open the circuit at a new location. If during the first open circuit test some devices restored, open the circuit at a location “electrically farther” from the Signature controller module and repeat the test. If during the first open circuit test no devices restored, open the circuit at a location “electrically closer” to the module, and repeat the test. Continue to increase or decrease the

number of devices on the opened circuit leg until you eventually isolate the single device or wire segment that is causing the problem.

Distinguishing short circuits from off-hook conditions in telephone risers

If local regulations require the ability to distinguish between a short circuit and an off-hook condition in a telephone riser, you must configure the circuit so that it functions as a 4-state telephone. The table below lists compatible riser selector modules and compatible telephone sets:

Table 8-27: Devices that can be used to configure a 4-state telephone

Riser selectors	Telephone modules
SIGA-CC1	Portable handset and receptacle (P/N 6833-1 and 6830-3)
SIGA-CC1S	
SIGA-MCC1	Remote telephone and wall box, Break Glass Type (P/N 6831-1 and 6830-1)
SIGA-MCC1S	

For instructions on configuring a four-state telephone, refer to the installation sheet supplied with the SIGA input or output module.

Ground fault conditions

Ground fault conditions require selective isolation of portions of the data circuit to systematically narrow down the fault's location. A circuit with a ground fault (approximately 10 k Ω or less to ground) will cause the LCD module to light the Ground Fault LED. Ground fault conditions can occur on the data circuit, the 24 Vdc smoke power circuit or the input circuits to Signature series modules. The general location of a ground fault can be determined using the LCD status command and Table 8-28 below.

Table 8-28: Ground fault indications

LCD	Ground Fault Location
Ground Fault LED ON No Device Trouble	1. Signature data circuit
	2. 24 Vdc smoke power circuit
Ground Fault LED ON Device PPCCDDDD Trouble	1. Positive leg of input circuit of device PPCCDDDD

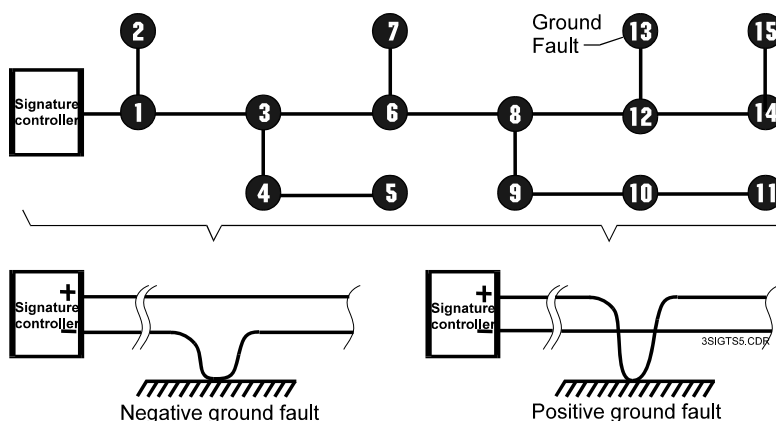

Figure 8-9: Signature data circuit ground faults

To isolate the ground fault, open the suspect circuit (both conductors) at a location that will disconnect approximately 50% of the installed devices. Figure 8-10 illustrates the technique on a data circuit. A similar technique is used on smoke power or module input circuits to isolate ground faults.

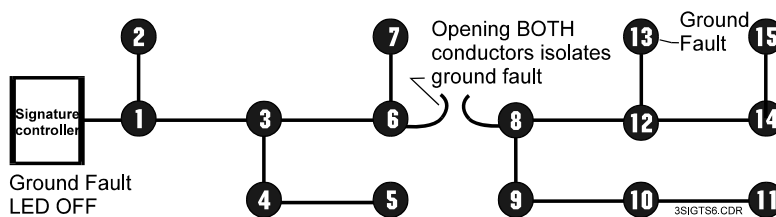

Figure 8-10: Ground fault isolation

If the LCD Ground Fault LED goes out, the ground fault is located on the portion of the circuit that has been disconnected.

If the LCD Ground Fault LED remains on and no devices restore, the short has been isolated to the first 50% of the circuit.

Re-connect the previously isolated portion of the circuit, and open the circuit at a new location. If during the first open circuit test the Ground Fault LED went off, open the circuit at a location “electrically farther” from the Signature controller module, and repeat the test. If during the first open circuit test the Ground Fault LED remained on, open the circuit at a location “electrically closer” to the 3-SSDC(1), and repeat the test.

Continue to increase or decrease the number of devices on the opened circuit leg and you will eventually isolate a single device or wire segment that is causing the problem.

The ground fault detection circuitry requires approximately 30 to 40 seconds to respond when the fault is removed.

The panel performs a ground fault test for 2 seconds at 40-second intervals. If the system is working properly, the voltage between earth ground and logic negative should be between 12.3 Vdc and 16.8 Vdc during the 2-second test. The system reports a ground fault when the voltages are less than 12.3 and more than 16.8. In a non-faulted system, the voltage outside the 2-second test period may float randomly, but if the system is faulted the voltage is likely to be a fixed value such as 3 or 19.

Substituting known good Signature series devices

When substituting a “known good” detector or module in place of a suspect device, one of two scenarios can take place.

If the substituted device is the same model as the suspect device, the system accepts it with no further operator action. When the substituted device is installed, the system goes into trouble.

When the quantity of devices defined on the circuit is reached, the system automatically remaps the circuit, stores the revised information, and returns to normal. This process may take a few minutes.

If the substituted device is a different model than the suspect device, when the device count is correct, the Signature controller module automatically remaps the circuit. A trouble occurs at the address of the suspect device as the result of a map fault, because the known good device’s parameters differ from those of the suspect device that was removed from the circuit. You must accept the parameters of the known good device to remove the map fault. These can be changed later.

You cannot use device substitution as a troubleshooting technique for Signature security devices. By design, the Signature controller does not automatically remap a replaced security device. This is intended to prevent swapping a security device with one that has been compromised for criminal purposes.

Detectors

When one or more devices are removed from a Signature Data Circuit for servicing, as shown in Figure 8-11, the panel will display a trouble condition for each device. If the System Definition Utility program (SDU) were connected to the panel, the DSDC Status screen would also indicate a trouble condition and the need to re-map.

If the detector is removed from an isolator base, the isolator will transfer.

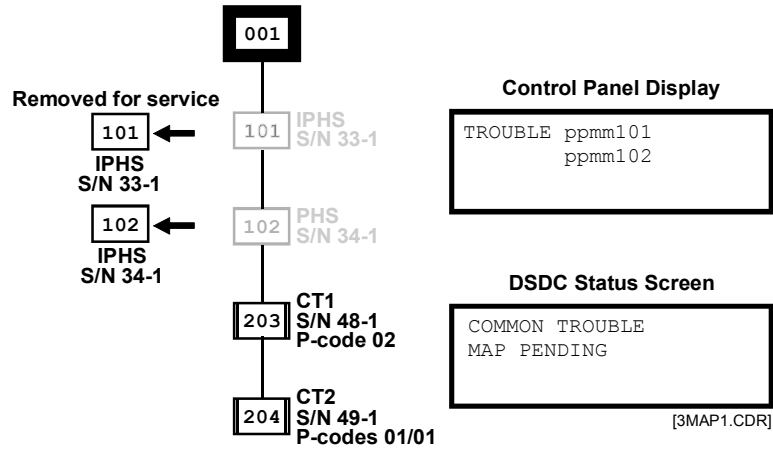

Figure 8-11: Detectors removed for service

If these devices are returned to their original locations, as shown in Figure 8-12, the map supervision function recognizes the detectors have been returned as originally installed (and mapped), and takes no additional action.

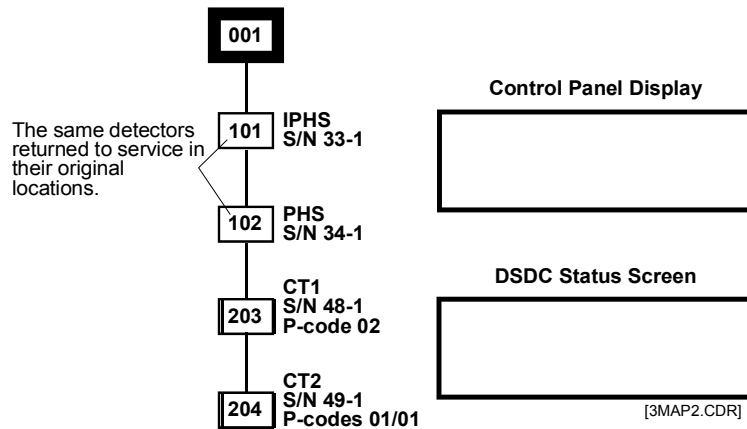

Figure 8-12: Detectors returned to service in original locations

If the devices are returned to the Signature Data Circuit but are not returned to their original locations, the map supervision function recognizes that previously mapped serial numbers occupy new map locations. Once the mapping supervision function has recognized the need to re-map the circuit, the panel is put in the “map pending” state. Once in the map pending state, the panel will automatically re-map the circuit when the quantity of devices re-installed on the circuit is equal to or greater than the quantity of devices defined in the original map. If the panel were connected to a computer running the SDU Program, the DSDC status function would indicate *map pending*.

In Figure 8-13, The PHS (S/N 34-1) originally installed at address 102 has been installed in the location originally occupied by the IPHS (S/N 33-1).

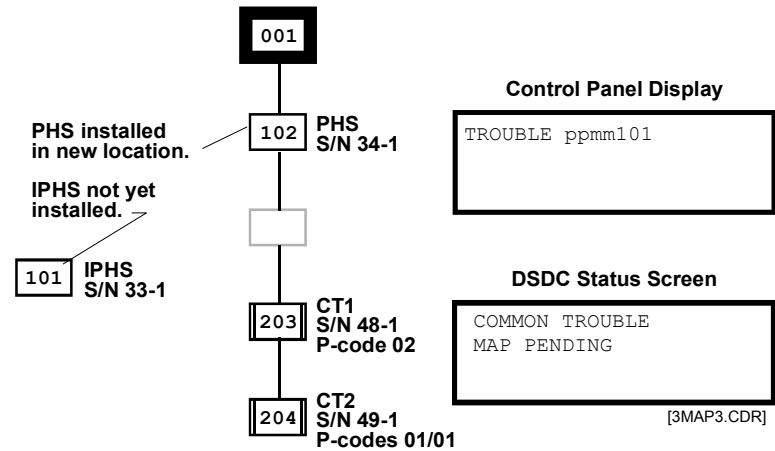

Figure 8-13: Partially restored circuit

Until all devices are re-installed on the circuit and the circuit is automatically re-mapped, the original S/N to panel address correlation is still valid. Examination of Figure 8-13 shows that the device address moves with the detector until the circuit is re-mapped. In this example, relocating the PHS detector temporarily relocated address 102. Until all devices are installed and the circuit re-mapped, testing a relocated detector will cause the panel to respond as though the detector was still installed in its original location.

During mapping, all devices remain operational and are capable of initiating an alarm. Figure 8-14 shows that both the IPHS and the PHS retain their old S/N to address correlations while the circuit is mapping. Mapping activity is indicated on the front panel display and the DSDC Status screen, if the data entry computer is connected.

Once mapped, the mapping supervision function will automatically correlate a panel address to a specific map location until manually changed using the data entry program.

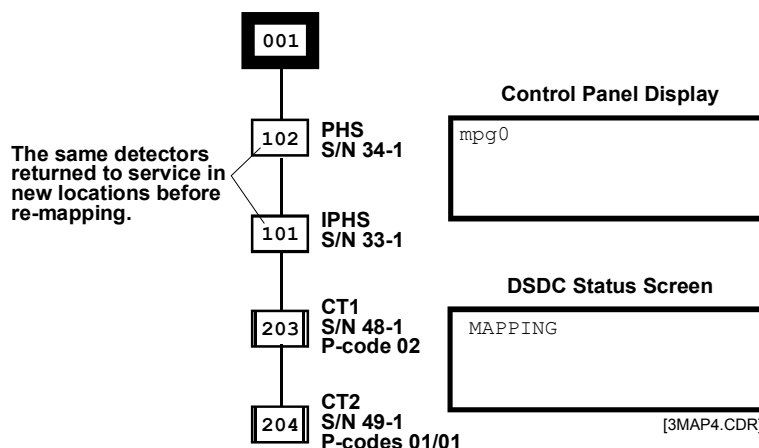

Figure 8-14: Detectors returned to new locations during re-mapping

Figure 8-15 shows the resultant map after re-mapping. Note that the new S/N to panel address correlations have been made, the IPHS is now correlated with address 102 and the PHS is correlated with address 101. The relocated devices will now respond as programmed for the original address location.

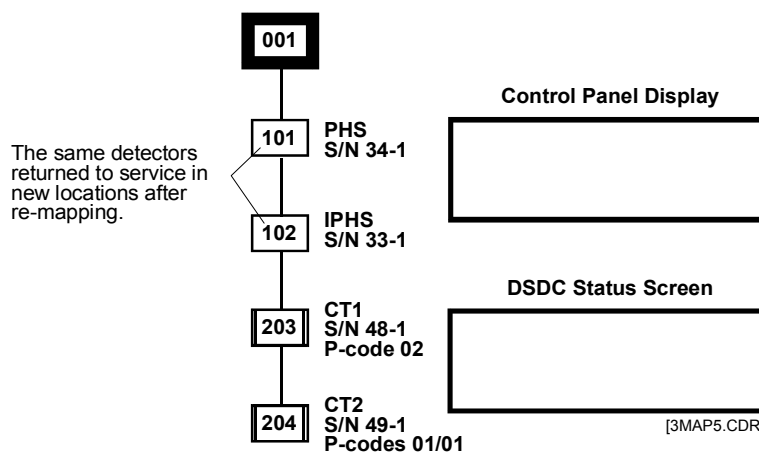

Figure 8-15: Final map

When a factory-new detector replaces an in-service detector, until mapped, the new detector is operational with a default address of 00. When the circuit is re-mapped, the new detector will be given the address assigned to its map location. If a factory-new detector is added over and above the expected number of devices on the circuit, it will be operational with a default address of 00, however the panel will be in trouble as the “actual map” contains one more device than the “expected map.”

Modules

When a module is replaced with another module of the same type, upon automatic re-mapping, the replacement module will be assigned the personality code of the module originally installed at that map location. If a module is replaced with a module of a different type one of three things can happen.

If you replace a single address module such as the SIGA-CT1, or SIGA-CC1, with a different type of single input module, the circuit will re-map all devices; however the new device type will not operate, due to incompatible personality codes. A map fault will be generated because the actual device differs from the expected device. The data entry program must be used to accept the new device type and clear the map fault.

Notes

- Do not replace factory-programmed devices such as pull stations and MM1 modules with a SIGA-CT1.
- For mapping purposes, give all manual pull stations the device type *pull*, regardless of their model numbers.

If a dual address module replaces a single address module, the panel will attempt to re-map all devices, however the circuit will not be successfully re-mapped. A map fault will be generated because the actual device differs from the expected device, and the dual address module will not operate. The data entry program must be used to accept the new device type and clear the map fault.

If a dual address module is replaced with a single address module, the panel will never attempt to re-map all devices because the panel does not see enough devices (one address less) to automatically re-map the circuit. The panel remains in the map pending mode and will not re-map. If the panel could be forced to re-map all devices, the circuit would still not be successfully re-mapped, because the actual device count differs from the expected device count. The panel will be in trouble with a map fault. The SDU program must be used to accept the new device type and clear the map fault.

Device type replacement

If a different Signature device model is substituted for the suspect device, when the device count is correct, the Signature controller module will automatically re-map the circuit. A trouble will occur at the address of the suspect device as the result of a map fault, because the known good device's parameters differ from those of the suspect device that was removed from the circuit. You must accept the parameters, which may be changed later, of the known good device to remove the map fault.

Signature series devices require a solid connection at their terminals. If a wire can be wiggled, it will be subject to contact resistance variations due to temperature changes, resulting in an intermittent connection, which will affect communication between the Signature devices and the control module. Use the proper size screwdriver and tighten all connections securely.

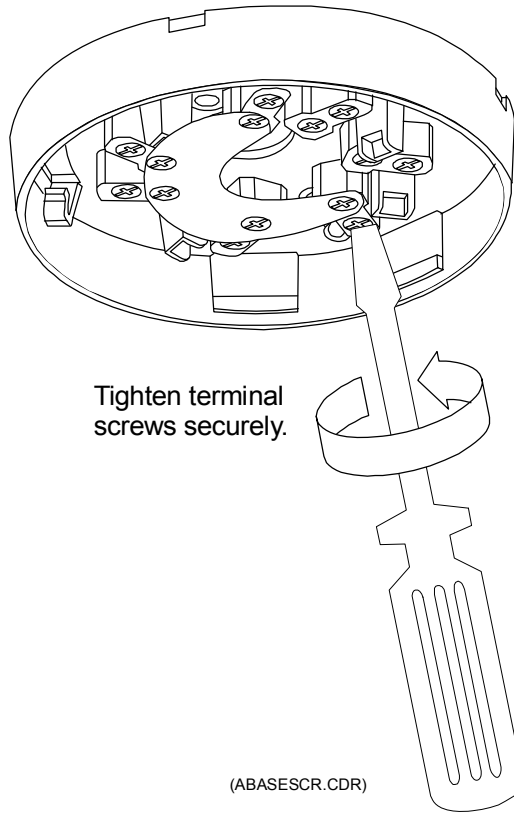

Signature controller modules

Substituting Signature controller modules

When substituting a “known good” Signature controller module in place of a suspect rail module, you must download the system configuration and Signature data circuit information into the CPU module. This operation requires a PC and the SDU Program.

The Signature controller module actually has two separate memories. The first memory contains the firmware that makes the module operate. If there is a problem with the firmware, or if an upgrade has been issued, the new firmware is downloaded into the module. When upgrading the module firmware (code), you do not need to download the “Bootstrap” data unless specifically instructed to do so.

The SDC configuration information is stored in the module’s second memory. If you suspect that the module itself is bad, you must download the configuration information for the circuit that will be connected to the substitute module.

The database must be converted before it can be downloaded into the Signature controller.

Table 8-29: Signature controller module troubleshooting

Problem	Possible cause
Signature Data Circuit Open	<ol style="list-style-type: none"> 1. Circuit incorrectly wired or connector loose 2. Defective detector or isolator base 3. Broken conductor 4. Device not installed on circuit 5. Device not entered into SDU databases
Signature Data Circuit Shorted	<ol style="list-style-type: none"> 1. Circuit incorrectly wired (often crossed wires on a device base) 2. Defective detector, detector base, or module 3. Nicked insulation between conductors
Signature Data Circuit Ground Fault	<ol style="list-style-type: none"> 1. Pinched wire between device and electrical box 2. Nicked wire insulation

Mapping errors

Table 8-30 provides basic information on mapping errors. For detailed information on identifying and locating mapping errors, refer to the SSDC Diagnostic and Status sections found later in this chapter.

Table 8-30: Mapping errors

Fault	Possible causes
Mapping Error	<ol style="list-style-type: none"> 1. A discrepancy between the internal map and the devices installed on the Data Circuit (serial #, personality code, or device type) 2. Device ID entered incorrectly into SDU database 3. More than 124 “T-taps” on a data circuit 4. Excessive circuit resistance 5. Excessive circuit capacitance
System continues to re-map data circuit	<ol style="list-style-type: none"> 1. An intermittent connection causing one or more devices to loose then re-establish communication with the Signature controller module 2. A defective device or detector base
Device Type Error	<ol style="list-style-type: none"> 1. There is a discrepancy between the device type recorded on the internal map and the device installed on the Data Circuit

Device troubleshooting

Each Signature series device has a red and green LED. Their functions are indicated in Table 8-31. These LEDs are useful when trying to determine the communication and alarm or active status of Signature devices.

Table 8-31: Signature device LEDs

LED	Device status
Green flashing	Normal communication
Red flashing	Alarm or Active (either input of dual input modules)
Red and Green steady	Stand-alone Alarm or Active (either input of dual input modules)

Table 8-32 lists common troubles and possible causes for Signature Series modules. For detailed information on identifying and locating Signature device problems, refer to the Signature Diagnostic Tools Section found later in this chapter.

Table 8-32: Signature module troubleshooting matrix

Module not responding correctly									Possible Causes
C C 1	C C 2	C R R	C R R	C T 1	C T 2	M M 1	U M	W T M	
x	x	x	x	x	x	x	x	x	Module installed in wrong location or improperly addressed
x	x	x	x	x	x	x	x	x	Module not entered into Signature database
x	x			x	x		x		Incorrect personality code loaded into module
					x		x		Personality code for unused portion of module not set at 0 (P-codes 1, 2, 3, 4, 8, 13, 14, 16, and 18)
							x		Jumper JP1 set incorrectly (P-code 8)
							x		24 Vdc for smoke power low or missing (P-codes 3, 14, 18, 20, and 21)
					x		x	x	Inputs 1 and 2 swapped (P-codes 1, 2, 3, and 4)
	x								Signal sources 1 and 2 swapped (P-code 7)
x	x	x		x	x	x	x	x	Ground Fault on data circuit or (-) side of input / output circuit

Module in trouble on Signature controller module

Table 8-32: Signature module troubleshooting matrix

x			x	x	x	x	x	x	Module missing or incorrectly wired on Signature data circuit.
x			x	x	x	x	x	x	Mapping error. Module not loaded into Signature database
x				x	x	x	x	x	Ground Fault on input or output circuit
x	x							x	Output circuit open, shorted, incorrectly wired, polarized device installed in reverse, incorrect or missing EOL resistor
				x	x	x	x	x	Missing or incorrect EOL resistor (P-codes 1, 2, 3, 4, 13, 14, 16, 18, 20, 21)
								x	24 Vdc for smoke power low or missing (P-codes 13, 14, 18, 20, and 21)
Module incorrectly in alarm or active on Signature controller module									
				x	x	x	x	x	Initiating device circuit shorted or initiating device incorrectly installed
				x	x	x	x	x	Incorrect EOL resistor value (too low)

x = Applicable for module

This table also applies to equivalent M-series components and products that emulate these module types.

Table 8-33: Signature detector troubleshooting

Symptom	Possible causes
Detector not responding correctly	<ol style="list-style-type: none"> 1. Detector installed in wrong location or improperly addressed. 2. Detector not entered in system database. 3. Incorrect device response in database.
Detector in trouble on CPU	<ol style="list-style-type: none"> 1. Detector missing or incorrectly wired on Signature data circuit. 2. Mapping error. Detector not loaded into control module database. 3. Ground Fault on Signature Data circuit 4. Internal detector fault. Refer to Advanced Techniques Section.
Detector incorrectly in alarm on control panel.	<ol style="list-style-type: none"> 1. Detector extremely dirty. 2. Ionization detector installed in area of extremely high airflow. 3. Detector installed in area of high ambient smoke. 4. Defective detector.

Signature diagnostic tools

The SDU Signature diagnostic tools are designed to assist the installing technician in isolating and correcting faults with the Signature Data Circuit (SDC), detectors and modules. The troubleshooting techniques described in the basic Signature troubleshooting section should be tried before using these tools.

Using Signature diagnostics

Tip: Signature diagnostic tools are on the SDU Tools menu.

To access the Signature diagnostic tools, Click Tools on the main menu bar, then click Signature Series diagnostics.

Signature device circuit selection

The Signature diagnostic tools affect only the SDC circuit that is specified in the drop down list boxes at the top of the DSDC Diagnostics window, as shown in Figure 8-16.

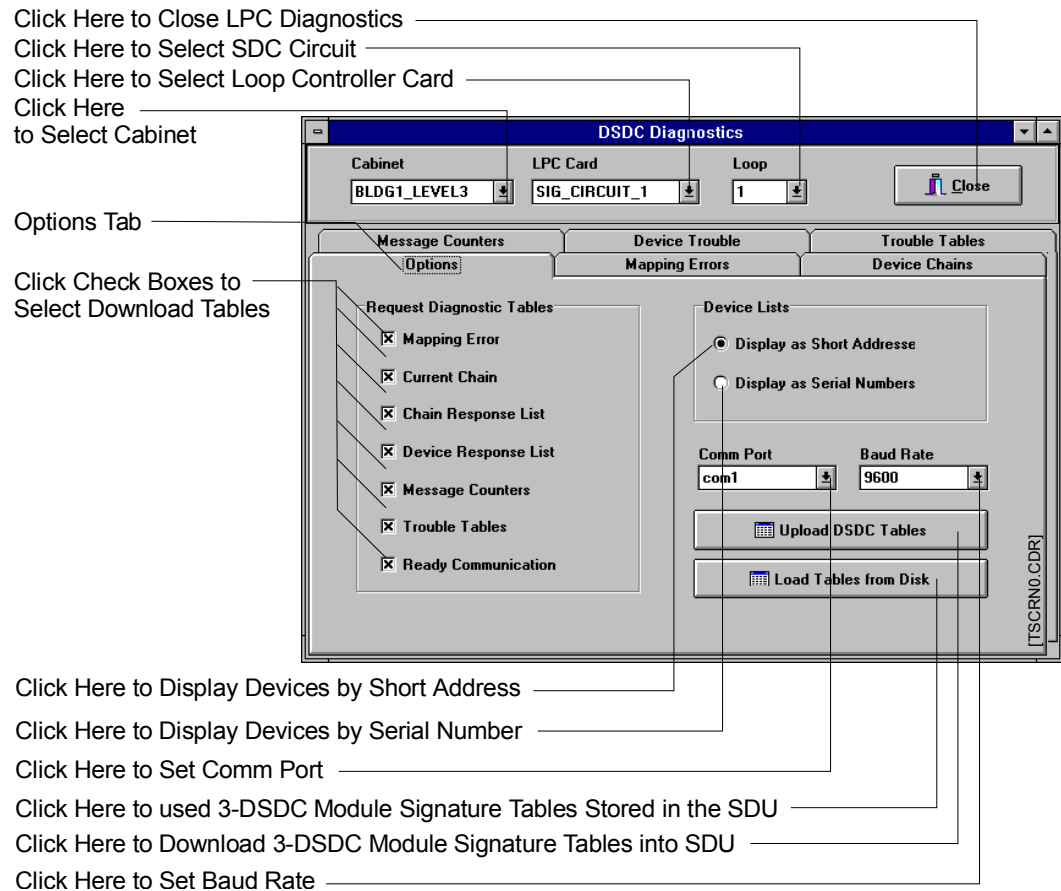

Figure 8-16: Options Screen

Select the cabinet that houses the Signature controller module with the trouble condition, using the Cabinet drop-down list.

Select the label of the Signature controller module with the trouble condition.

Select the loop (Signature Data circuit) on the module having the trouble condition, using the loop (SDC) drop down list.

Note: You must upload Signature data from the Signature controller module into the SDU program before you can use the Signature diagnostic tools.

COM port and baud rate

To use the Signature diagnostic tools, the information from the faulty Signature data circuit or device must first be read (uploaded) into the System Definition Utility (SDU) program. Use the COM Port and Baud Rate drop down lists to set the COM port parameters on the SDU computer that is to be used during uploading. The suggested baud rate is 19200.

Upload

To upload the Signature data from the Signature controller module into the SDU program, click the Download DSDC Tables button. When the Signature data has been downloaded from the Signature controller module, it is stored as part of the project. The Signature data can be recalled without being connected to the module by using the Load Tables from Disk button.

Serial number or short address

The devices listed in the diagnostic tables can be displayed by serial number or short address. You can mix short address and serial number displays using the Requested Diagnostic Table check boxes and the Device Lists radio buttons in combination.

Signature diagnostic sequence

Table 8-34 lists the suggested sequence when using the Signature Diagnostic tools to isolate problems on a Signature Data Circuit and problems with individual Signature devices.

Table 8-34: Signature troubleshooting tool sequence

SDC circuit faults	Signature device faults
1. Mapping Errors	1. Device Tables
2. Device Chains	2. Trouble Tables
3. Message Counters	

Displaying mapping errors

Mapping errors prevent the system from generating a successful Signature Data Circuit map. To display errors generated during the mapping process, click the Mapping Errors tab. The Mapping

Errors text box lists the eight (8) most recent mapping errors. The Total Errors field lists the total number of mapping errors that have been identified. Clicking on an error in the list highlights the error, and displays the appropriate troubleshooting tip in the lower Troubleshooting Tips text box.

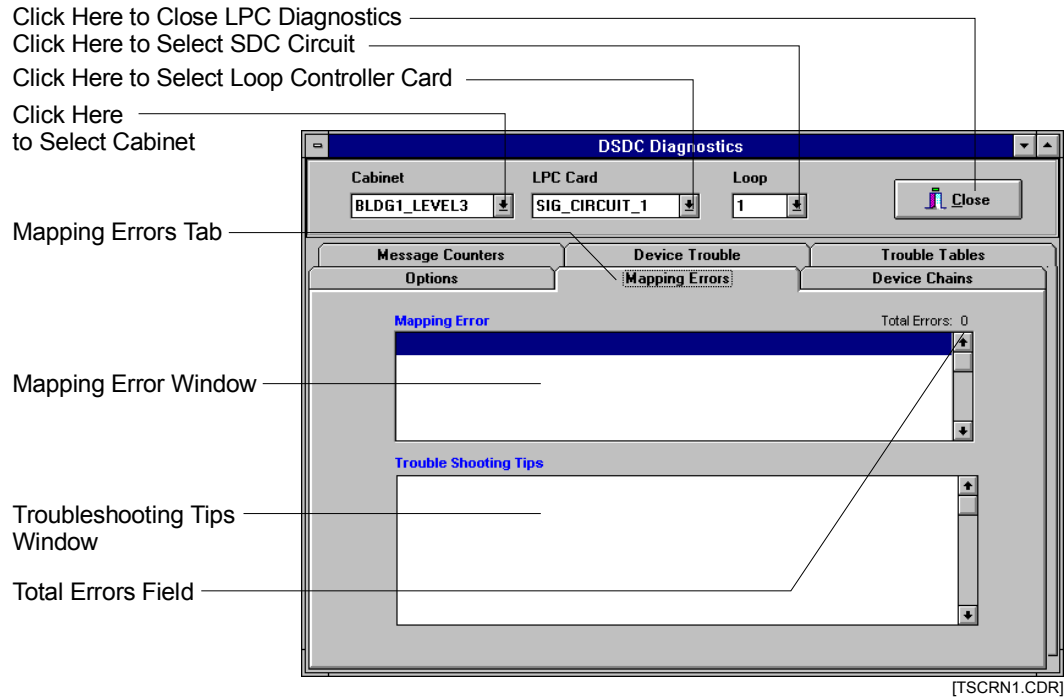

Figure 8-17: Mapping errors dialog box

Table 8-35: Mapping error messages

Message	Suggested corrective action
The mapping command failed because the sensor did not draw current or it was not possible to obtain stable mapping data from the SDC.	Indicative of faulty wiring on the circuit, or a faulty device. <ol style="list-style-type: none"> 1. Verify correct wiring. 2. Verify operational devices. 3. Review the Chain Response List. 4. Review the Device Response List.
While mapping a chain from a device back to the Signature controller module, the chain was built with “holes” in it.	Indicative of devices not operating consistently. <ol style="list-style-type: none"> 1. View the Chain and Device Response Lists to see a list of the devices that are present in the chain being processed. 2. Compare the serial numbers in the above lists with the actual wiring to identify a conflict.

Table 8-35: Mapping error messages

Message	Suggested corrective action
The map tables are inconsistent.	<ol style="list-style-type: none"> 1. Upload the current map. 2. Compare current map with expected map. 3. Write the map back to the Signature controller module.
The actual SDC map does not match the stored expected map.	<ol style="list-style-type: none"> 1. Upload the current map. 2. Compare current map with expected map. 3. Write the map back to the Signature controller module
Setting the Address in the device failed.	<ol style="list-style-type: none"> 1. Review the Serial Number or Short Address. If missing, replace the device. 2. Persistent problem is indicative of a wiring fault.
Map supervision failure. The map in use has invalid data. This error initiates an automatic reconstruction of the map.	<ol style="list-style-type: none"> 1. Please wait for automatic map reconstruction to complete before continuing.
Mapping supervision detected a change on the SDC. A rebuild of the map was scheduled.	<ol style="list-style-type: none"> 1. Please wait for automatic map reconstruction to complete before continuing.
Mapping supervision detected that the device address or the short address of the device being supervised has changed. A rebuild of the map was scheduled.	<ol style="list-style-type: none"> 1. Please wait for automatic map reconstruction to complete before continuing.
The mapping command failed, the sensor did not draw current or it was not possible to obtain stable mapping data from the SDC. A rebuild of the map was scheduled.	<ol style="list-style-type: none"> 1. Please wait for the automatic map reconstruction to complete before continuing.
Mapping was aborted by an external event, such a new start on a device. A rebuild of the map was scheduled.	<ol style="list-style-type: none"> 1. Please wait for the automatic map reconstruction to complete before continuing.
Mapping supervision detected that the Device Type of the Device being supervised has changed. A Map Fault was flagged.	<ol style="list-style-type: none"> 1. Replace the device. 2. Correct the Signature controller module programming.
Mapping was aborted because there is short or open on the SDC wiring.	<ol style="list-style-type: none"> 1. An open or short on a Class A circuit. 2. A short across the entire Class B circuit. 3. A Reset may be needed to restart mapping.
Unable to recreate current map at panel startup. The panel will re-map to reconstruct the map.	<ol style="list-style-type: none"> 1. Please wait for the automatic map reconstruction to complete before continuing.

Table 8-35: Mapping error messages

Message	Suggested corrective action
Assignment of a short address to a device failed. This could lead to duplicate short addresses and mapping failures.	<ol style="list-style-type: none"> 1. View the Chain and Device Response Lists to see a list of the devices that are present in the chain being processed and identify the failed device. 2. Replace the device. 3. Persistent problem is indicative of a wiring fault.
Mapping has been disabled.	<ol style="list-style-type: none"> 1. Enable mapping.
While mapping a chain from a device back to the Signature controller module, the chain appears to have 2 devices at the same location in the chain.	<ol style="list-style-type: none"> 1. Indicative of faulty wiring on the circuit, or a faulty device. 2. Review the Chain and Device Response lists to identify the conflict.
More than 125 End of Line devices have been found on the SDC.	<ol style="list-style-type: none"> 1. Correct the wiring. 2. Re-map the circuit.
While mapping a chain from a device back to the Signature controller module, the chain was found to have a device present past the end of the chain. This indicates that at least one device is responding improperly to the mapping commands.	<ol style="list-style-type: none"> 1. Click the Device Chains tab to see a list of the devices that are present in the chain being processed. 2. Compare the serial numbers or short addresses with the actual wiring to identify the problem.
Mapping has detected a difference between the device at the end of line and the devices in its chain.	<p>This indicates that devices not communicating properly.</p> <ol style="list-style-type: none"> 1. Click the Communication List tab to see a list of the devices that are communicating. 2. Compare the serial numbers or short addresses with the actual wiring, in order to identify the conflict.

Displaying device chain errors

A chain is a list of devices connected between the Signature controller module and a device being interrogated during circuit mapping. The chains and sub-chains created during the mapping process evolve into the circuit map.

Should a circuit fail to map properly, further insight into the problem may be gained by investigating the devices making up individual chains and sub-chains.

To display a chain generated during the failed mapping process, click the Device Chains tab. Four categories of device chains are listed. Each list displays the short address or serial number of the devices in the chain. The total number of entries in each list is indicated at the bottom of the list. To determine the position of a specific Signature device in the chain, click the small data entry box at the top of each column and enter the device's short address or serial number. The position field at the bottom of the column will indicate the selected device's chain position and the cursor will move over that device entry in the main list.

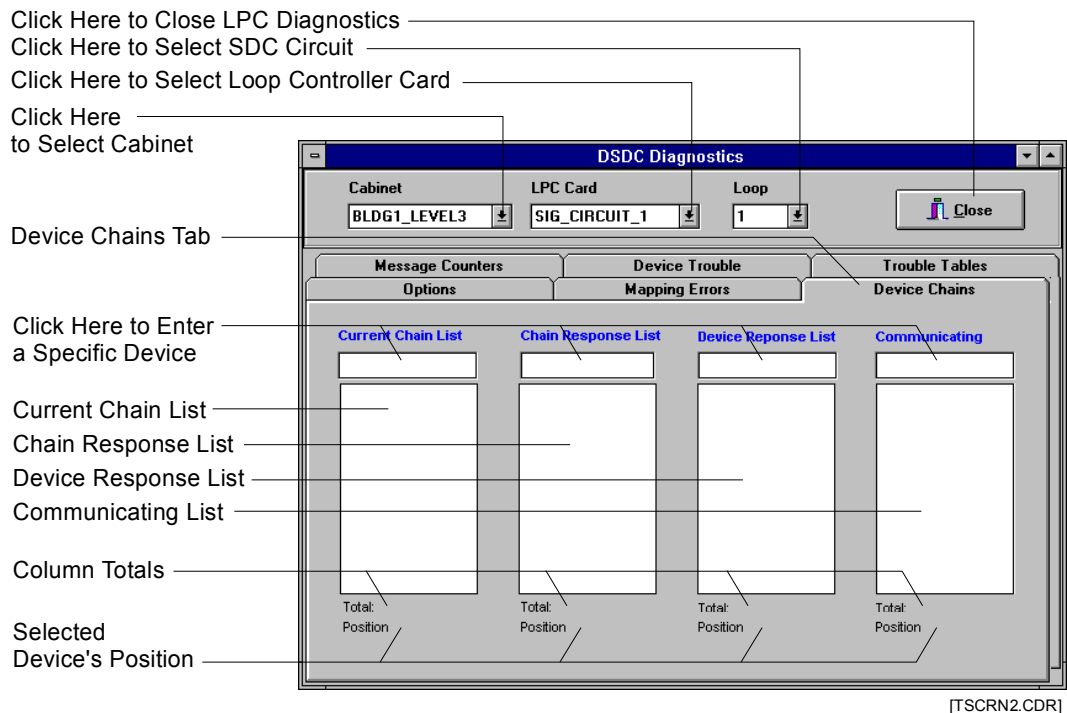

Figure 8-18: Device chains dialog box

Current chain list

The Current Chain List displays the sequence of Signature devices in the chain or sub-chain that was being created when the mapping failure occurred.

Chain response list

The Chain Response List displays the sequence of Signature devices in the *main chain*, when the mapping failure occurred.

Device response list

The Device Response List displays the sequence of Signature devices in a *sub-chain* that was being created when the mapping failure occurred.

Communicating list

The Communicating List displays a list of all Signature devices seen by the Signature controller module.

Using the chain lists

An element in the displayed chain caused the map fault. Examine the chain and look for gaps within the short address or serial number lists of a chain or sub-chain.

- Gaps in the list indicate areas that were not successfully mapped. A gap within the chain does not mean that the missing device has a problem, only that that device was not successfully mapped.
- Compare the Chain and Device response lists. All the devices on the Device Response list should also appear on the Chain Response list.
- Look for duplicate short addresses or serial numbers on the same list.

Failure of a device to successfully map may be the result of a problem with another device, or wiring in a chain or sub-chain not directly connected to the unmapped device. Although the missing or duplicate devices are not always the cause of map failure, good troubleshooting technique suggests that these devices be examined for defects, wiring errors, and duplicate entries in the SDU program, etc.

Displaying message counters

During normal operation, the Signature controller module issues numerous communication messages to the Signature devices on its SDCs. The message counters indicate how many times a communication message has been issued and the number of successful return messages.

To display the message counters, click the Message Counters tab.

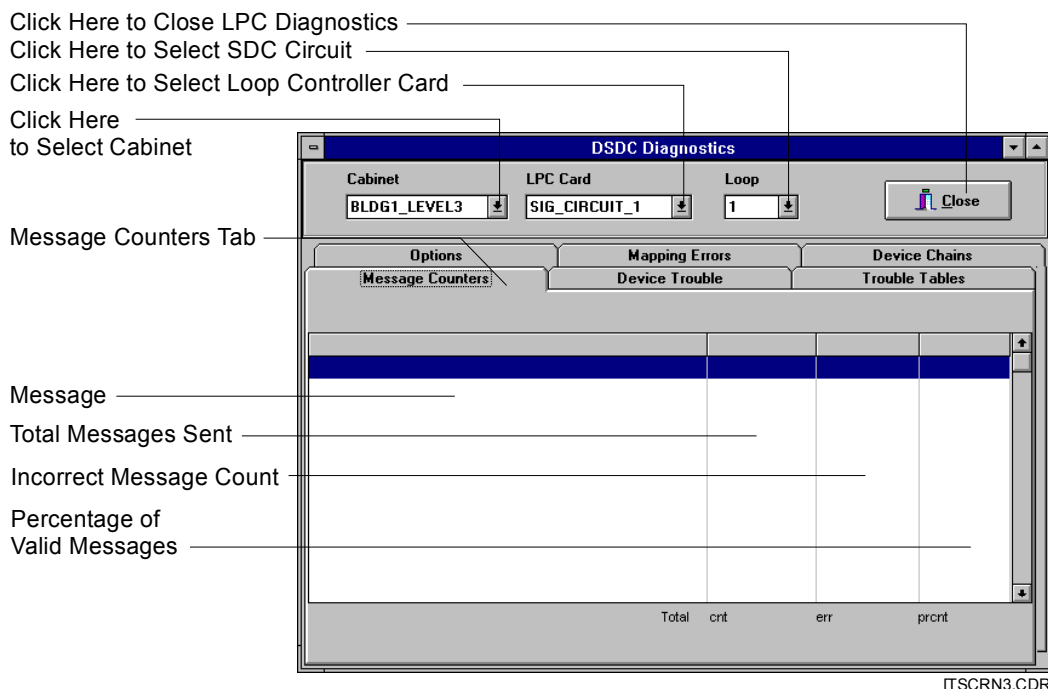

Figure 8-19: Message counters dialog box

The message command appears in the left column, followed by the number of times it has been issued, the number of errors received after the message was issued, and the percentage of correct responses. During normal operation, the percentage of messages received correctly should exceed 99%.

Intermittent device or wiring problems are indicated by a low successful message rate. If successful message rates are tracked over time, one can generate base line information for each circuit. From the base line information, any changes from the norm can be quickly identified, and preventive measures taken, before a communication problem develops. Table 8-36 lists the messages sent and received by the Signature driver controller module.

Table 8-36: Signature controller module Internal Messages

Query End Of Line	Query Relay Status	Find New Start
Query Isolator	Ground Fault Check	Find New Active
Query Status	Query Device Mask	Find New Unused2
Pulse Visible LED	Query Group Mask	Find New Unused3
Query Map Result	Module PFX	Reset Device
Query Alarm Status	Query Ready Comm	Enable Device
Query PreAlarm Status	Find Serial Number	Disable Device
Query Normal Status	Find New Alarm	Start Device

Table 8-36: Signature controller module Internal Messages

Query Trouble Status	Find New PreAlarm	Enable Visible LED
Query New Start Status	Find New Normal	Disable Visible LED
Query Active Status	Find New Trouble	Enable External Output
Disable External Output	Assign All Address	3-SDC Processor Status Query
Open Line Isolator	Relay Control	3-SDC Enable Loop
Close Line Isolator	Read Software Version	3-SDC Disable Loop
Reset Device Status	Read Device Status	3-SDC Line Initialization Complete
Move EEPROM to RAM	Read Sensor Values	3-SDC Send a Device Msg.
Assign Short Address	Read Specific Trouble	3-SDC Get a Device Reply
Assign Group Address	Read Value From RAM	3-SDC Configure Loop
Enter Service Mode	Send Value to Visible LED	3-SDC Query Current Configuration
Select Sensors	Query New Status	3-SDC Send Signal Rate
Write Value to RAM	3-SDC Command Initiate Reset	3-SDC Query Signal Status
Write Value to EEPROM	3-SDC Command Initiate Restart	

Displaying device trouble

Each Signature device is equipped with a 32-bit trouble register. Should a device's trouble bit be set *at any time in the device's history*, the device and the nature of the trouble will appear in the Latching Troubles By Device Address window. Clicking on the device will reveal a list of the trouble conditions affecting that device. Click the device a second time to remove the trouble listing.

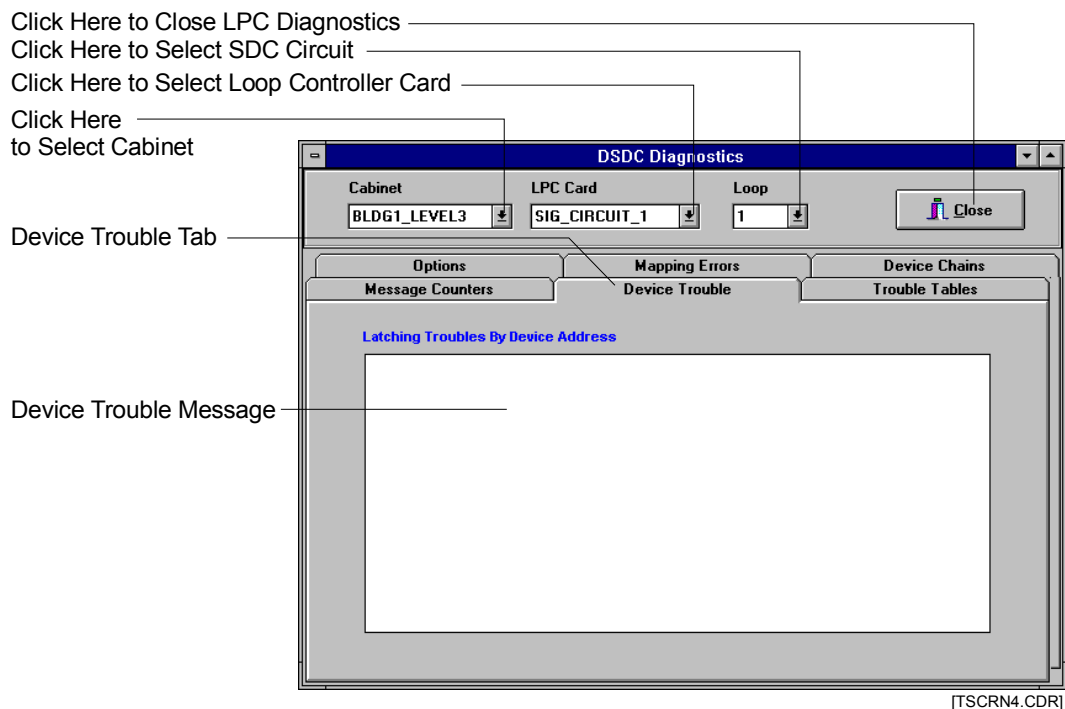

[TSCRN4.CDR]

Figure 8-20: Device trouble dialog box

Table 8-37 below lists the Signature *Detector* trouble messages, and possible causes and solutions. Table 8-38 lists the Signature *Module* trouble messages, and possible causes and solutions.

Table 8-37: Signature detector trouble messages

Trouble message	Possible cause	Possible solution
External Device Line Short	Defective Detector	Replace Detector
External Device Line Open	Defective Detector	Replace Detector
Error XMIT Light	Detector Dirty	Clean detector
Device switched to short after isolator relay operated	Short on Signature data circuit	Locate and remove cause of short.
ESK Value Too Low	1. Dirty Detector 2. Bad Ion Chamber	1. Clean Detector 2. Replace Detector
ESK Slope Too High	1. Dirty Detector 2. Bad Ion Chamber	1. Clean Detector 2. Replace Detector
ESK Slope Too Low	1. Dirty Detector 2. Bad Ion Chamber	1. Clean Detector 2. Replace Detector
Quiescent Too Large	Devices on the Signature data circuit are drawing too much current during the mapping process.	Place a short or low resistance shunt across the data circuit.

Table 8-37: Signature detector trouble messages

Trouble message	Possible cause	Possible solution
Quiescent Too Small	Devices on the Signature data circuit are not drawing enough current during the mapping process.	Check the device wiring or replace the device.
Short on Relay Base	Bad Relay Base	Replace Relay Base
External or Isolator Relay Failure to Switch	Bad Base	Replace Base
External or Isolator Relay Switched	1. Bad Relay Base 2. External Electrical Noise	1. Replace Relay Base 2. Remove or Shield Noise Source
“O” Value Too Small	Bad Base	Replace Base
Ion Rate-of-Rise Too High	Bad Ion Chamber	Replace Detector
Ion Quiescent Too High	Dirty Detector	Clean Detector
Ion Quiescent Too Low	Dirty Detector	Clean Detector
Ion Value Too Low	Defective Detector	Replace Detector
Thermal Value Too High	Bad Base	Replace Base
Thermal Value Too Low	Bad Base	Replace Base
A/D Converter Fault	Defective A/D converter	Replace Detector
EEPROM Checksum Error	Bad EEPROM	Replace Detector
EEPROM Write Time-out	Bad EEPROM	Replace Detector
Unknown Device Type	Bad EEPROM	Replace Detector
EEPROM Write Verify Fault	Bad EEPROM	Replace Detector
Ambient Light Too High	1. Dirty Detector 2. Outside light reaching detector chamber	1. Clean Detector 2. Eliminate light source
Photo Quiescent Too High	Dirty Detector	Clean Detector
Photo Quiescent Too Low	Dirty Detector	Clean Detector
Photo Value Too High	Bad Base	Replace Base

Table 8-38: Signature module trouble messages

Trouble message	Possible cause	Possible solution
Open data Circuit	See Table 8-32	See Table 8-32
Shorted data Circuit	See Table 8-32	See Table 8-32

Table 8-38: Signature module trouble messages

Trouble message	Possible cause	Possible solution
Relay switched	Relay toggled from actual state	Manually reset relay Replace Module
Data circuit ground fault	See Table 8-32	See Table 8-32
Vector Current Too Large	Devices on the Signature data circuit are drawing too much current during the mapping procedure.	Short or low resistance shunt on Signature data circuit
Vector Current Too Small	Devices on the Signature data circuit are not drawing enough current during the mapping procedure.	Excessive circuit resistance Defective base Defective wiring
EEPROM Not Initialized	EEPROM not properly programmed	Replace module
EEPROM Write Time-out	Bad EEPROM	Replace module
A/D Time-out	Defective A/D converter	Replace module
EEPROM Write Verify Fault	Defective EEPROM	Replace module
Line Monitor Trouble	Signature data circuit voltage low	Check Signature data circuit
Class A Trouble	Open or shorted input or output circuit	Check input / output circuit wiring
3rd Wire Trouble	Voltage is out of range on the wire that supplies 24 Vdc power to SIGA-UM.	Check power supply output Check wiring
3rd Wire Trouble	Voltage on the wire supplying 24 Vdc smoke power to SIGA-UM is out of range.	Check power supply output. Check wiring
RAM Not Programmed	Bad RAM	Replace Module

Displaying trouble tables

Note: You must be actively connected to the network via download cable to display the trouble tables.

The Trouble Tables display eight categories of *active* device trouble. Each list displays the short address or serial number of the devices experiencing that trouble condition. The total number of devices in each list is indicated at the bottom of the list.

The active troubles displayed in the Trouble Tables should be compared with a device's trouble history displayed in the Display Device Trouble lists, to determine any possible trouble pattern.

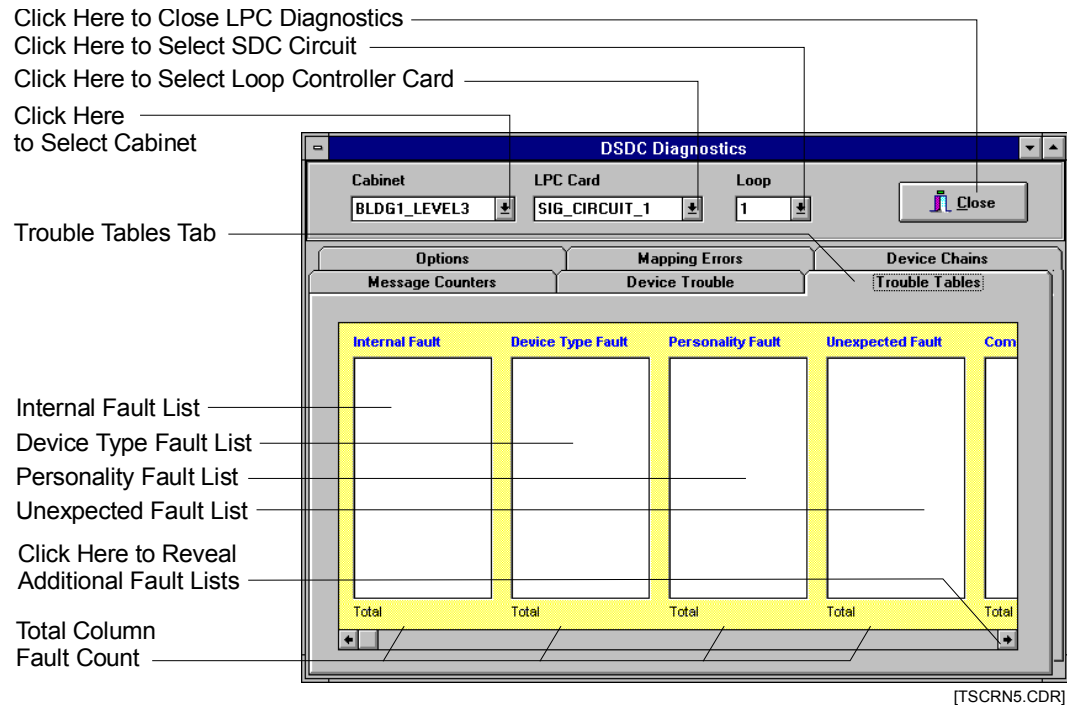

Figure 8-21: Trouble Tables dialog box

Internal fault

The Internal Fault List indicates an internal problem with a Signature Device or Module. Refer to the Displaying Device Trouble section to determine the specific cause.

Device type fault

The Device Type Fault List indicates that the device type entered in the SDU does not agree with the device type installed on the SDC.

Personality fault and sensitivity fault

The Personality Fault List indicates that the personality code (p-code) of a Signature module entered in the SDU does not agree with the p-code of the module actually installed on the circuit. The Sensitivity Fault List indicates that the sensitivity of a Signature detector entered in the SDU does not agree with the sensitivity of the detector actually installed on the circuit.

Personality and sensitivity faults should be corrected by the system, and these faults should clear automatically.

Unexpected fault

The Unexpected Fault List displays the serial number of devices which appear on the actual circuit, but which were not listed in the SDU program.

Communication fault

The Communication Fault List indicates those Signature devices that are not communicating with the Signature controller module.

Open fault

The Open Fault List indicates those Signature modules with an open on their input or output circuits (all p-codes except 8.)

Ground fault

The Ground Fault List indicates those Signature modules with a ground fault on their input or output circuits (all p-codes except 8.)

Short fault

North American marketplaces: The Short Fault List indicates those Signature modules with a short on their supervised output circuits (p-codes 5, 7, 15, 16.)

European marketplace: The Short Fault List indicates those Signature modules with a short on their supervised input circuits (p-codes 1, 2, 3, 4, 9, 10, 11, 12, 13, 14, 20, 21) and those Signature modules with a short on their supervised output circuits (p-codes 5, 7, 15, 16.)

Brand fault

Incorrect brand of Signature devices installed on SDC.

DSDC status

Introduction

The DSDC status function is used to determine the *real-time* status of a Signature Data Circuit (SDC). This function is useful in isolating and correcting faults on an SDC. The DSDC status function is useful in conjunction with the download and DSDC diagnostic functions.

Setting up the System Definition Utility program

In order to use the DSDC Status function, the computer running the SDU program must be connected to the 3-SSDC(1). The appropriate communication port must be connected to the modular phone jack on the Signature controller module or on the CPU module.

Com port and baud rate settings can be made directly from the DSDC Status window. The default baud rate is 9600 baud.

Using DSDC status

To access the DSDC Status function, click Tools > Signature Status.

Select the SDC to be monitored by using the Cabinet, SSDC, and Loop drop down lists.

The Delay drop down box sets the interval at which the status screens receives updated information from the Signature controller module. The default value is 3 seconds. Increasing the delay time permits the module to process more information between reports to the SDU, thus decreasing the overall time it takes to generate a full status report.

To start the DSDC Status function, click the Start Status Button. Should the Confirm window appear after a short delay, the SDU computer is not communicating with the 3-SSDC(1).

Verify the module address, download wiring, COM port, and baud rate are set correctly and click the retry button. If communications fail when connected to the module via the CPU, try connecting directly to the modular phone jack on the Signature controller module.

Displaying the current SDC status

Click the Current Status Tab at the bottom of the window to display an annunciator panel showing the real-time status of the connected SDC. Refer to Table 8-39 to interpret the indicators.

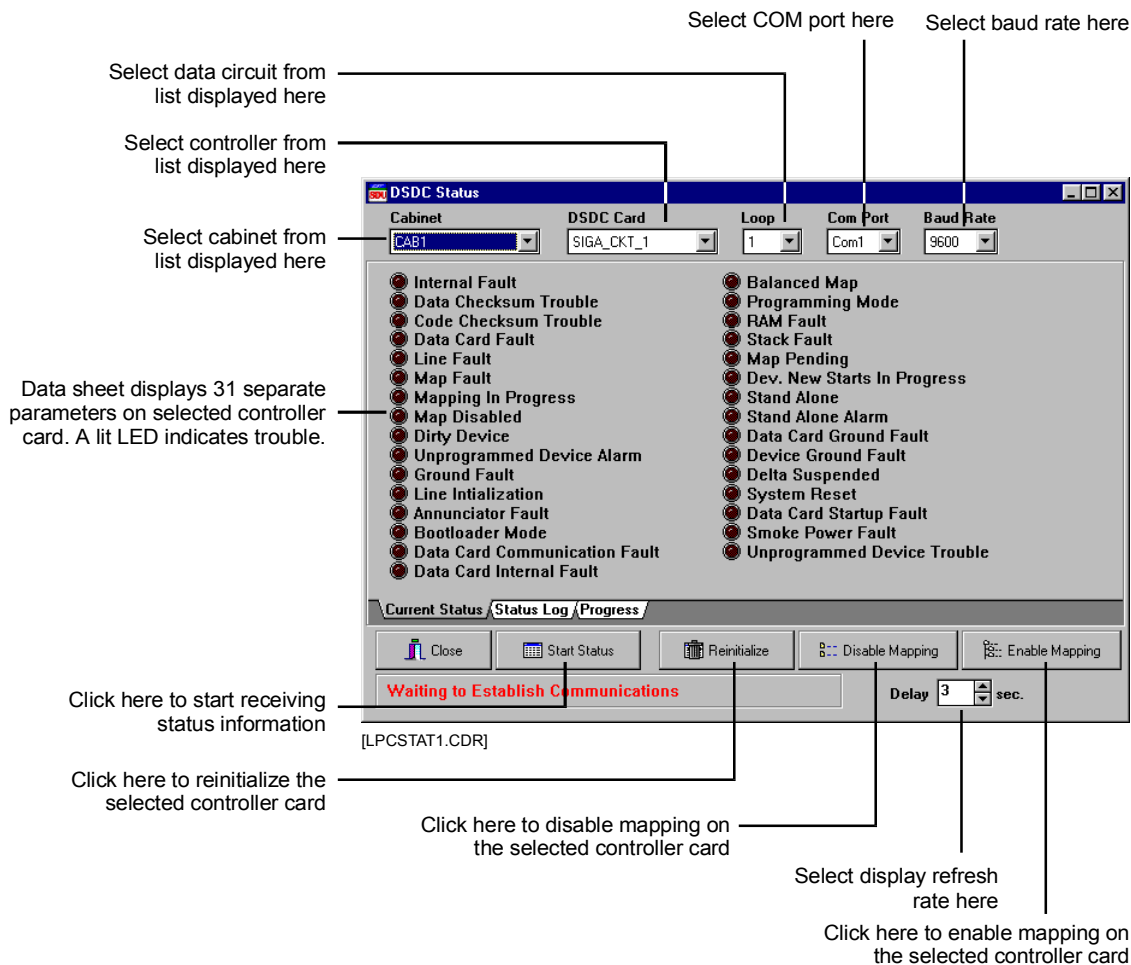

Figure 8-22: DSDC Status dialog box

Table 8-39: Current status parameters

Indicator	Function
Internal Fault	Signature controller module hardware problem
Data Checksum Trouble	Configuration data bad
I/F Fault	3-SDC Card hardware problem
Line Fault	SDC open or shorted
Map Fault	Memory contents differ from actual SDC device conditions.
Mapping in Progress	The Signature controller module is currently mapping the SDC
Map disabled	The mapping process has been manually turned off

Table 8-39: Current status parameters

Indicator	Function
Dirty Device	A dirty smoke detector has been identified
Unconfigured Alarm	The module has detected an alarm on a device which is not in its database
Line Initialization	SDC power on phase, devices not supervised
Serial Table Full	Indicates when data controller card needs to be reinitialized
I/F Communication Fault	Signature controller module to 3-SDC communication problem
I/F Internal Fault	3-SDC card hardware problem
Balanced Map	Two or more device strings appear identical to the system.
Programming Mode	Signature controller module in upload or download mode
RAM Fault	Internal memory problem
Stack Fault	Internal program error
Map Pending	Ready to map SDC when SDC conditions warrant
Dev. New Starts in Progress	The Signature controller module is processing a new SIGA device start up
Stand Alone	The SDC is in the stand alone mode
Stand Alone Alarm	The module has detected an alarm while in the stand alone mode
Ground Fault	The SDC wiring has low resistance continuity to ground
Device Ground Fault	A SIGA module IDC/NAC has low resistance continuity to ground
Delta suspended	Module in reset phase. No changes reported by Signature controller module

Displaying a log of current SDC status events

Click the Status Log Tab at the bottom of the window to display a chronological list of the events that occurred on the SDC after the Start Status Button was activated.

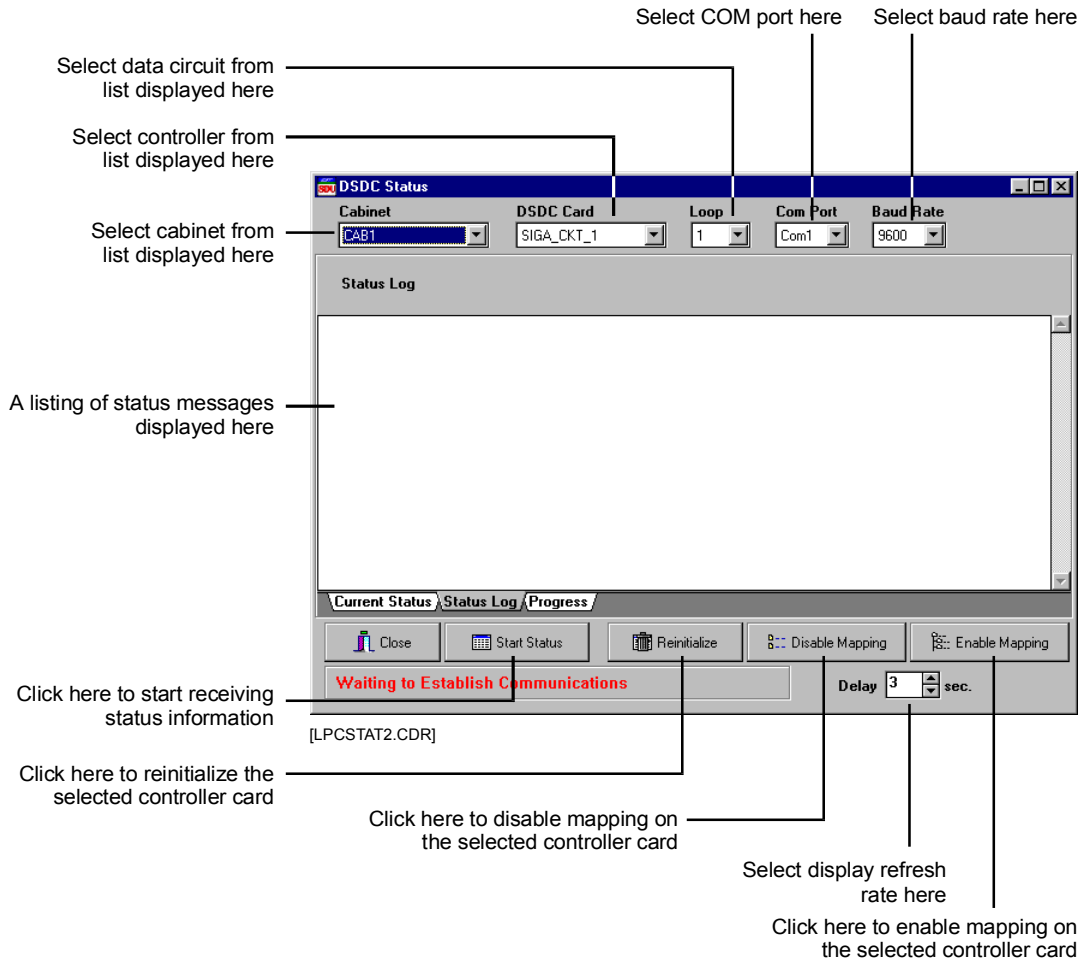

Figure 8-23: DSDC status event log

Displaying the SDC in-process progress chart

Click the Progress Tab at the bottom of the window to display a graphical presentation of the five major processes that take place during SDC configuration:

- Finding device serial numbers
- Communicating with individual devices
- Mapping the devices
- Verifying the End Of Line (EOL) status of a device
- Programming parameters into a device’s memory

This display is useful in determining an overall picture of SDC configuration activity.

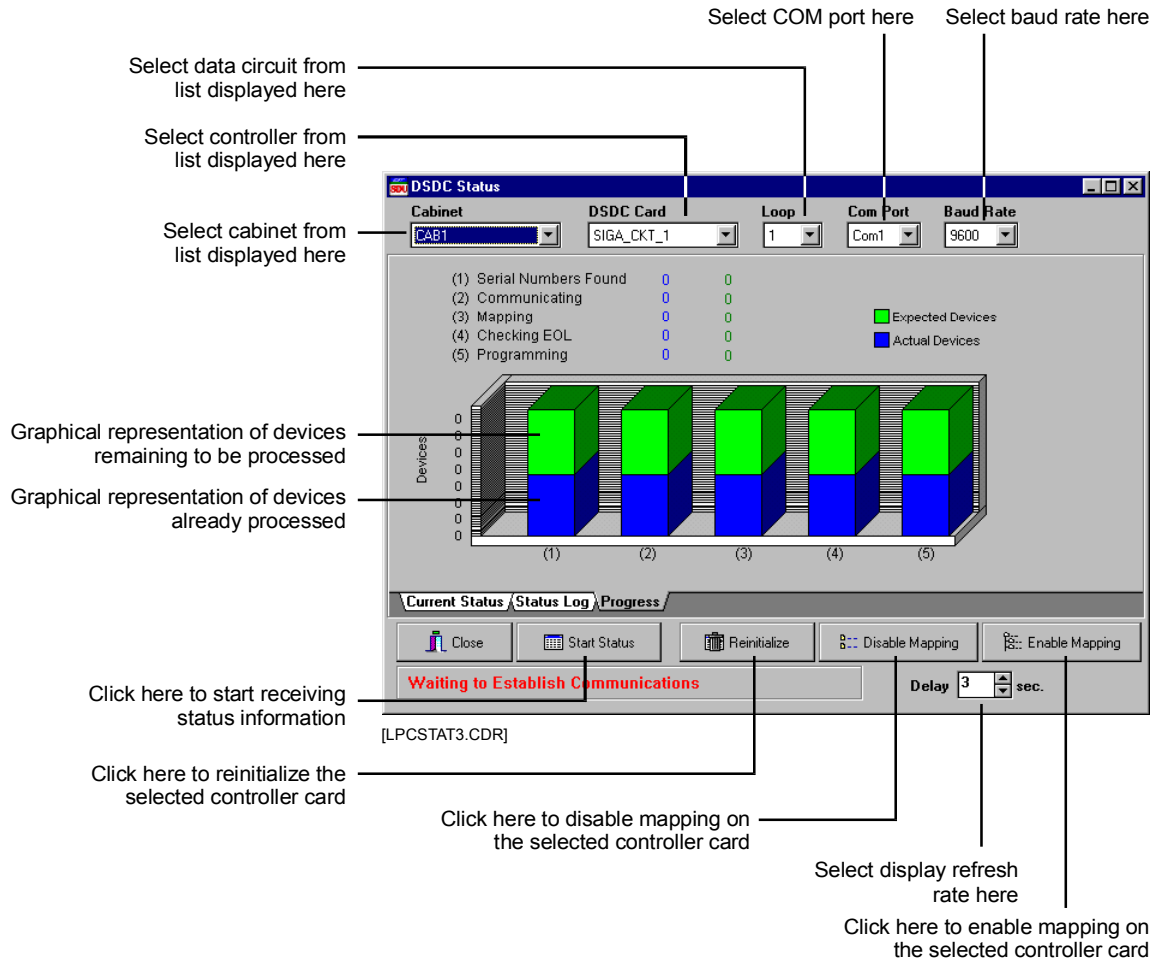

Figure 8-24: DSDC in-process progress chart

Addressable analog diagnostic tools

The SDU addressable analog diagnostic tools are designed to assist in isolating and correcting faults with addressable analog circuits, detectors, and modules.

System definition utility

The quickest method for isolating most common problems is with the Systems Definition Utility (SDU) diagnostic tools.

1. Connect the computer that runs the SDU to the system, and open the appropriate project.

If the actual project is not available, create a phantom project with an empty 3-AADC1 circuit and connect directly to the module in question.

2. From the menu bar, select Tools > System Sensor > Diagnostics.
3. On the Options tab, clear the selection from Message Counters, and upload. Trouble Tables, Ready Communication, and Display as Device Addresses should be selected.
4. Click: Upload AADC Tables.
5. Select the Status Tables tab when the table upload is complete.

Addressable analog diagnostic table interpretation

Each table lists the addresses for the modules and sensors reporting the associated condition with a total at the bottom. When displayed as Device Addresses, sensor addresses correspond with the rotary switch setting, and modules are reported as 100 plus the rotary switch setting. Multiple faults will make the process more difficult but the addresses noted in the fault tables make an excellent starting point

Table 8-40: Addressable analog diagnostic table interpretation

Table Name	Description	Possible causes
Communicating Devices	Lists sensor and module addresses talking to the 3-AADC1.	Total number of communicating devices should equal number of installed devices. If total is low, see Communication Fault table for missing or not connected device(s). If total is high, see Unexpected Fault table for extra device(s) installed on circuit.
Internal Fault	Devices reporting an internal failure	Replace device

Table 8-40: Addressable analog diagnostic table interpretation

Table Name	Description	Possible causes
Device Type Fault	The wrong device type for the current configuration.	Photo detector installed for ion detector Ion detector installed for photo detector Monitor module installed for control module Control module installed for monitor module Two device addresses are transposed.
Unexpected Fault	A device is reporting at an unconfigured address. All unconfigured addresses are polled at startup and at 10-minute intervals thereafter.	If the total number of Communicating Devices is correct, and a Communication Fault is reported, the Unexpected Fault device should be set to the address listed as a Communication fault.
Duplicate Device Fault	Two or more devices have the same address.	If the total number of Communicating Devices shown in the table is correct, a device has been assigned the same address as a configured device. If the total number of Communicating Devices is too low, and a Communication Fault is reported, the device in the Communication fault table is addressed at the location shown in the Duplicate Device table.
Communication Fault	Missing device.	Wiring error or device not installed If Communicating Devices table short by one and Duplicate Device fault exists, then address shown in Comm Fault table is addressed at location shown in Duplicate Device table. OR If Communicating Devices table OK and Unexpected Fault exists, then the Unexpected Fault device should be set to the address shown in the Communication Fault table.
Open Fault	Module field wiring is open.	Circuit incorrectly wired or connector loose Defective detector or isolator base Broken conductor Device not installed on circuit Device not entered into SDU databases
Short Fault	Module field wiring is shorted.	Circuit incorrectly wired Defective detector, detector base, or module Nicked insulation between conductors

Table 8-40: Addressable analog diagnostic table interpretation

Table Name	Description	Possible causes
Compatibility Fault	Incorrect brand of device installed, replace device.	SIGA, GSX, or XLS brand devices intermixed on circuit.

Problem solving hints

Addressing faults

Most addressing faults are quickly located because the wrong address gives a clue as to the fault location. For example module 164 is duplicated while module 174 is missing. The device at location 174 probably has its tens digit addressing switch off by one position.

Duplicate device faults are harder to locate, e.g. the carpenter put up a partition hiding sensor 53, then the electrician noticed it was missing and spliced in a new base and now there are two sensors at address 53.

To identify devices with duplicate addresses, remove one of the suspected duplicate sensors. The duplicate fault should clear within 30 seconds if the sensor removed is a duplicate. Disconnect half of the circuit. Allow a minute or so for the circuit to stabilize and the faults to report. Upload the “Ready Communication” diagnostics table only. The remaining duplicate sensor, 53, should still appear, as if it is physically connected between the circuit controller and the wiring break. Continue to add or remove segments of the circuit in gradual increments repeating the diagnostics upload until the physical location of the problem detector is located.

Intermittent communication and wiring faults

EST3 counts of the number of communications and errors associated with each device. You can use this information to diagnose problems.

- A message counter tracks the number of communications sent between each device and the 3-AADC1 controller.
- An error counter tracks the number of communications failures occurring between each device and the 3-AADC1 controller

Both counts return to 0 each time the controller is restarted. You can use these To help to isolate a problem, compare the number of messages sent to a specific device to the number sent to a neighboring device of the same type.

Devices are polled each time the system is started, and any time an object reports its status as trouble or alarm. Polling frequency

differs for different objects and circumstances. Pull stations are polled much more frequently than detectors or modules. Devices that report communication failure are polled more often than devices that are not experiencing the failure.

- Devices with high message counts but few errors may be pull stations or devices that change state regularly such as monitor modules.
- Devices that have increased error counts and only marginally increased message counts may indicate wiring or device problems.
- Devices with low message counts and an equal number of errors are non-existent devices.
- All 198 addresses are polled occasionally to identify any devices that may have been installed and not configured.

If the message and error counts are confused because of the length of time the circuit has been running, restarting the panel will cause a restart of the circuit and zero the counters. You may need to monitor the circuit for twenty minutes or more before a trend in messages becomes apparent. Locating intermittent faults may require extended operating periods.

3-AADC1 Addressable Analog Driver Controller

Substituting 3-AADC1 local rail modules

When substituting a known good 3-AADC1 rail module in place of a suspect rail module, you must download the system configuration and Addressable Analog circuit data circuit information into the CPU module. This operation requires a PC and the SDU Program.

The 3-AADC1 actually has two separate memories. The first memory contains the firmware that makes the module operate. If there is a problem with the firmware, or if an upgrade has been issued, the new firmware is downloaded into the module using the 3-AADC1 Code tab, which is found in the Version Control (Code) function of the Tools, Download menu. When upgrading the module firmware (code), you do NOT need to download the “Bootstrap” data unless specifically instructed to do so.

The SDC configuration information is stored in the module’s second memory. If you suspect that the module itself is bad, you must download the configuration information for the circuit that will be connected to the substitute module, using the 3-AADC1 Database tab, which is found in the Version Control (Database) function of the Tools, Download menu.

Connect the PC to the CPU RS-232 connector J5.

Table 8-41: 3-AADC1 Local Rail Module troubleshooting

Problem	Possible cause
Analog Circuit Open	<ol style="list-style-type: none"> 1. Circuit incorrectly wired or connector loose 2. Defective detector or isolator base 3. Broken conductor 4. Device not installed on circuit 5. Device not entered into SDU databases
Analog Circuit Shorted	<ol style="list-style-type: none"> 1. Circuit incorrectly wired 2. Defective detector, detector base, or module 3. Nicked insulation between conductors
Analog Circuit Ground Fault	<ol style="list-style-type: none"> 1. Pinched wire between device and electrical box 2. Nicked wire insulation

Addressable analog device troubleshooting

Each addressable analog device has an integral Red LED. The function of this LED is indicated in Table 8-42. The LED is useful when trying to determine the communication and alarm or active status of a device.

Table 8-42: Addressable analog device LEDs

LED	Device status
Flashing Red	Polling device
Steady Red	Alarm or Active

Table 8-43 lists common troubles and possible causes for addressable analog modules.

For detailed information on identifying and locating these errors, use the SDU program's Addressable Analog Diagnostic Tools. Information about these tools appears later in this chapter.

Table 8-43: Addressable analog module troubleshooting matrix

Module not responding correctly				
M500 MF	M501 MF	M500 CF	M500 XF	Possible Causes
x	x	x	x	Module is installed in the wrong location or is improperly addressed
x	x	x	x	Module has not been entered into 3-AADC1 database
-	-	x	-	Break-off tab is set incorrectly
x	x	x	x	A ground fault has occurred on data circuit or (-) side of input / output circuit
Module in trouble on 3-AADC1 circuit				
x	x	x	x	Module is missing or is incorrectly connected to the circuit
x	x	x	x	ID error. Module has not been loaded into the 3-AADC1 database.
x	x	x	x	A ground fault has occurred on input or output circuit
-	-	x	x	The output circuit may be open, shorted, or incorrectly wired. A polarized device may be installed in reverse. The EOL resistor may be missing or incorrect
x	x	x	x	Missing or incorrect EOL resistor
Module incorrectly in alarm or active on CPU/LCD module				
x	x	-	-	Initiating Device Circuit may be shorted, or an initiating device is incorrectly installed

x	x	-	-	EOL resistor value is too low
---	---	---	---	-------------------------------

x = Applicable
 - = Not applicable

Table 8-44: Addressable analog detector troubleshooting

Symptom	Possible causes
Detector not responding correctly	<ol style="list-style-type: none"> 1. Detector installed in wrong location or improperly addressed 2. Detector not entered into system database 3. Incorrect device response in database
Detector in trouble on CPU/LCD	<ol style="list-style-type: none"> 1. Detector missing or incorrectly wired on circuit 2. ID error. Detector not loaded into 3-AADC1 module database. 3. Ground Fault on circuit 4. Internal detector fault
Detector incorrectly in alarm on CPU/LCD	<ol style="list-style-type: none"> 1. Detector extremely dirty 2. Ionization detector Installed in area of extremely high airflow 3. Detector installed in area of high ambient smoke 4. Defective detector

For detailed information on identifying and locating device problems, refer to topic “Addressable analog diagnostic tools,” earlier in this chapter.

Wiring problems

There are three basic causes of wire-related erratic Addressable Analog circuit operation:

Excessive wiring resistance

Rarely is excessive wiring resistance the sole cause of Addressable Analog circuit problems. For any length of cable, the amount of resistance and capacitance per foot doesn't change and the Addressable Analog circuit capacitance limits are usually reached before the resistance limits. The digital signal operates between 0 and 24 Vdc. Excessive circuit resistance causes the signal to shrink from a maximum of 23 Vdc to a lower voltage, for example 20 Vdc. The 3-volt drop in the wiring is due to wire resistance.

To measure Addressable Analog circuit voltage drop, use an oscilloscope to measure the peak voltage at the Addressable Analog module and at each analog addressable device. If the voltage difference is greater than 2 Vdc, the resistance in the wire run is excessive. Too much resistance in the Addressable Analog wire run is typically caused by small wire size or a bad connection.

If the wire size is too small for the run length, the only remedies are to replace the wire with a larger size, or install additional Addressable Analog modules, dividing the circuit into acceptable lengths. Breaks or bad connections in the Addressable Analog circuit wiring can be identified by comparing the calculated circuit resistance value (described earlier) with the measured circuit resistance value. The measured wiring circuit resistance should not be different from the calculated circuit resistance by much more than a few ohms.

Excessive wiring capacitance

The second cause of erratic Addressable Analog circuit operation is too much capacitance in the Addressable Analog circuit wiring. Capacitance distorts the digital signal. As wiring capacitance increases, the square edges of the digital waveform start to curve. Excessive wiring capacitance causes the waveform to curve beyond the point where a device can recognize the waveform and respond when polled.

Wiring capacitance also effects the turn-on current spike. If the turn on current spike is not present in the digital sequence, there is a high probability the analog addressable device's communication will not be understood by the Addressable Analog communication module.

Addressable Analog circuit capacitance problems are typically caused by long wire runs, ground faults on the Addressable Analog circuit, improper T-taps, or improper shielding.

If shielded wire is used, the shield must be treated as a third conductor. It must be free of all ground faults and have continuity throughout. If the wire capacitance is too large for the run length, the only remedies are to replace the wire with a cable having a lower capacitance per foot or install additional Addressable Analog modules, dividing the circuit into acceptable lengths.

Ground faults

Eliminating ground faults on the Addressable Analog circuit reduces the amount of capacitance on the Addressable Analog wiring.

Verify the Addressable Analog circuit is free of ground faults.

Correcting addressable analog circuit wiring problems

If the Addressable Analog circuit is wired with improper T-taps or excessive capacitance, corrective measures include:

- Designing the Addressable Analog circuit properly and re-pulling the wire
- Balancing the circuit. Balancing the circuit can help in some cases but is not a substitute for proper wiring practice. If circuit balancing is required, call Technical Services for additional information.

Summary

This appendix provides a quick reference for interpreting the mapping of system addresses.

Content

- Address format • A.2
- LRM addresses • A.4
- Control / display module addresses • A.9
- Device addresses • A.10

Address format

Tip: To determine a local panel's cabinet number, use the LCD command menu to get the status on all the active points on the panel. When prompted for a panel number, enter 00. The panel returns the startup response point's logical address. The first two numbers of the logical address is the cabinet number.

The system derives the addresses it assigns from the panel's cabinet number and the LRM's location within the panel (see Figure A-1). The basic address format is PPCCDDDD, where:

PP is the panel's cabinet number. The cabinet number is assigned when the installer downloads the CPU database into the panel.

CC is the LRM's slot address. The cabinet number and the slot address make up the LRM's logical address.

DDDD is the device's point address. The LRM's logical address and device's point address make up the device or circuit's logical address.

The CRC Card Reader Controller and KPDISP Keypad Display are devices supported by a 3-SAC module. However, they also act as independent processors, and have their own pseudo points. For this reason, their device numbers are further subdivided.

You can think of a SAC device as having this address format: PPCCSSDD: SS is the CRC or KPDISP device number, as assigned during LRM configuration. DD is a pseudo point within the device.

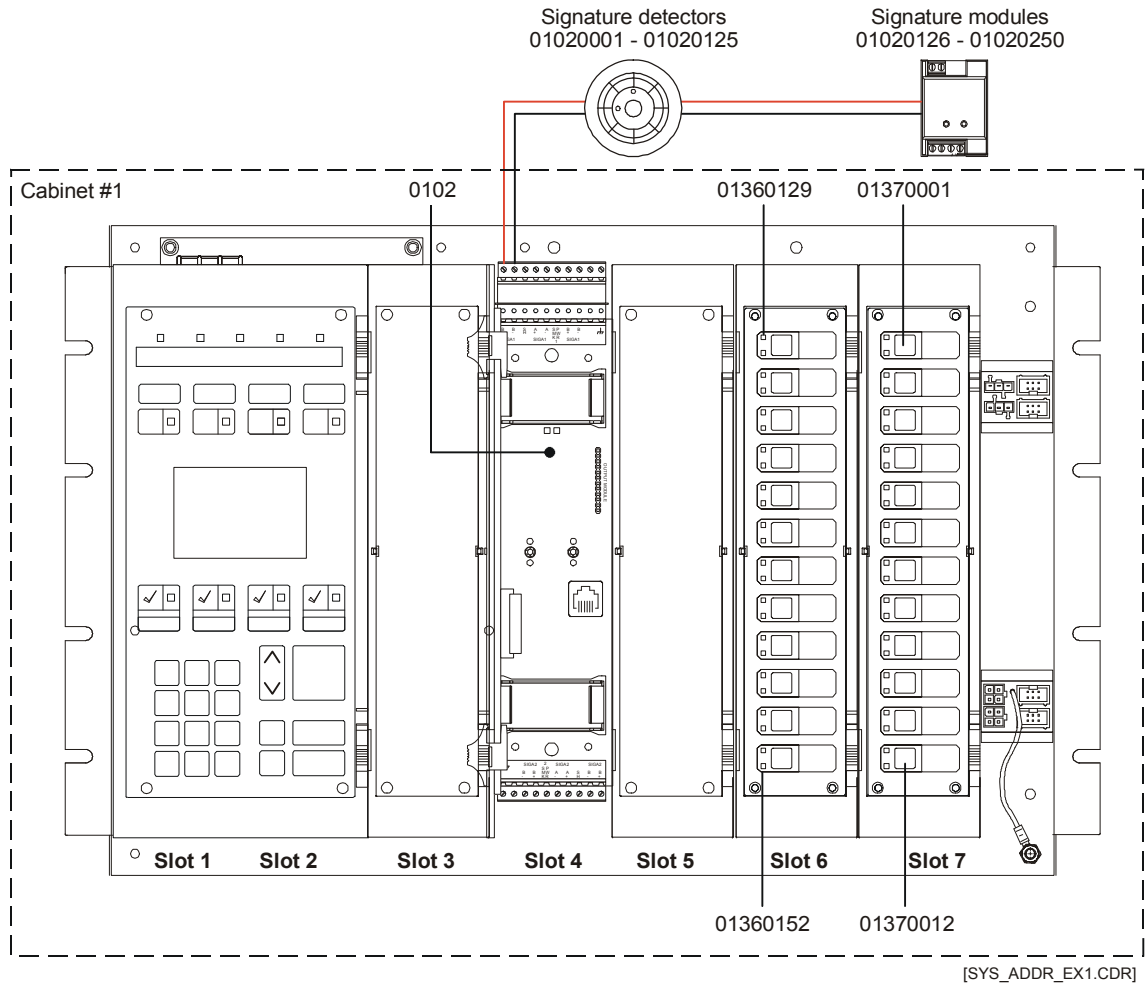
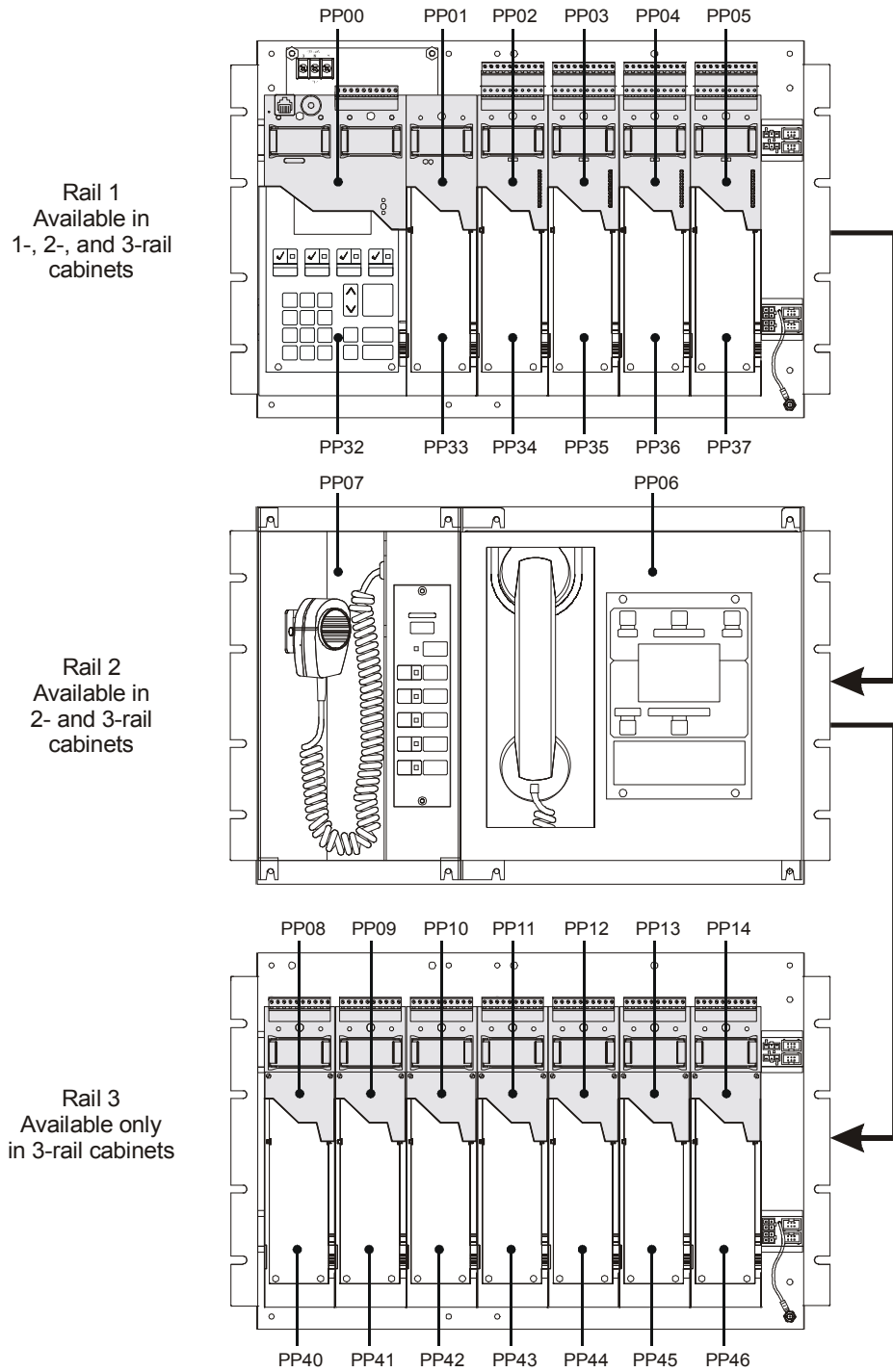

Figure A-1: Addressing example

LRM addresses

Figure A-2, Figure A-3, and Figure A-4 show the logical addresses that the system assigns to LRMs based on the panel configurations. Figure A 5 shows the effect of using a wide LCD module, such as the 3 LCDXL1 Main LCD Display.



[LRM_ADDR_01.CDR]

Figure A-2: LRM addresses for 3-CHAS7, 3-ASU/FT, 3-CHAS7 configuration

System addresses

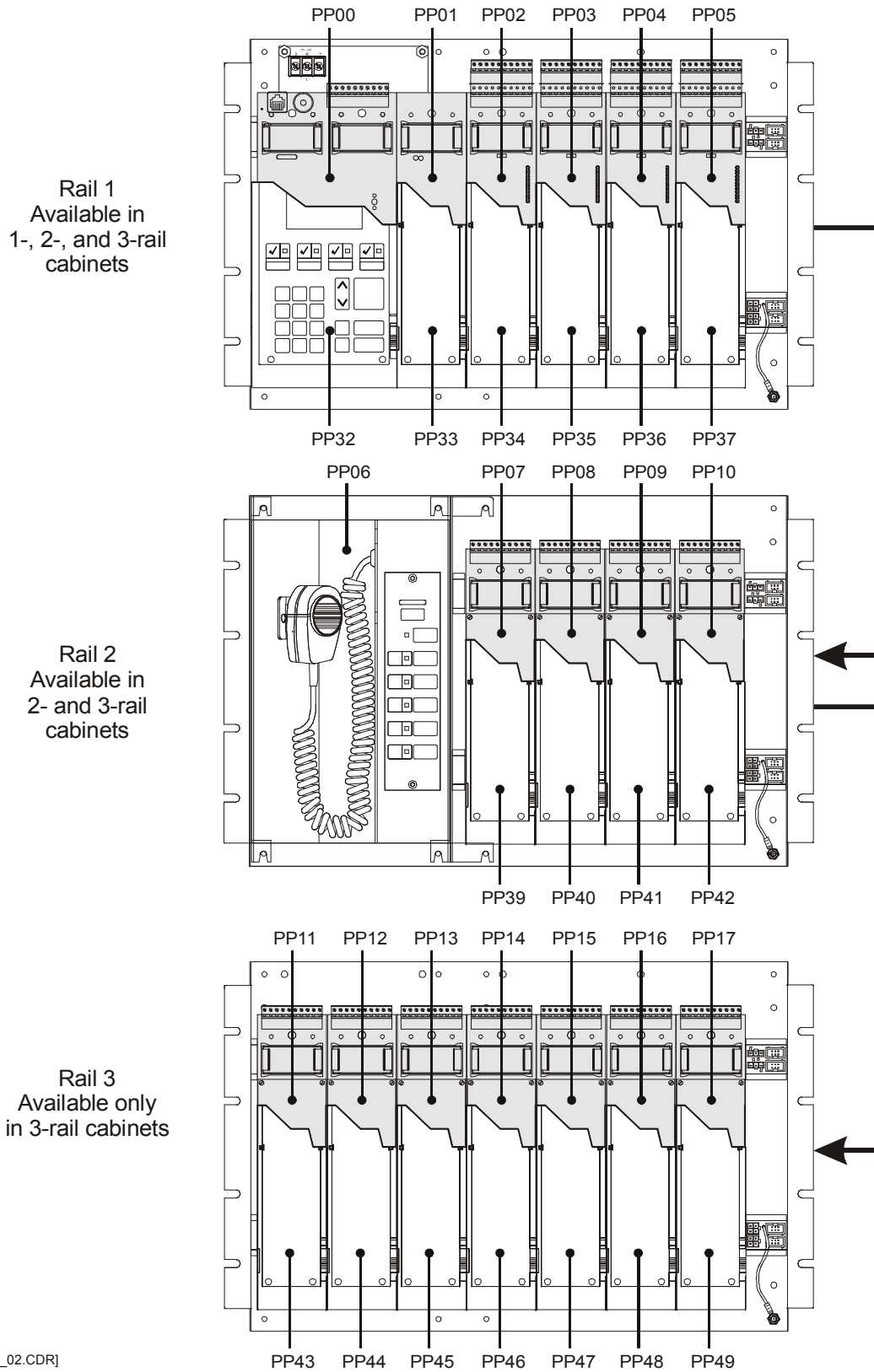

[LRM_ADDR_02.CDR]

Figure A-3: LRM addresses for 3-CHAS7, 3-ASU/CHAS4, 3-CHAS7 configuration

Rail 1
Available in
1-, 2-, and 3-rail
cabinets

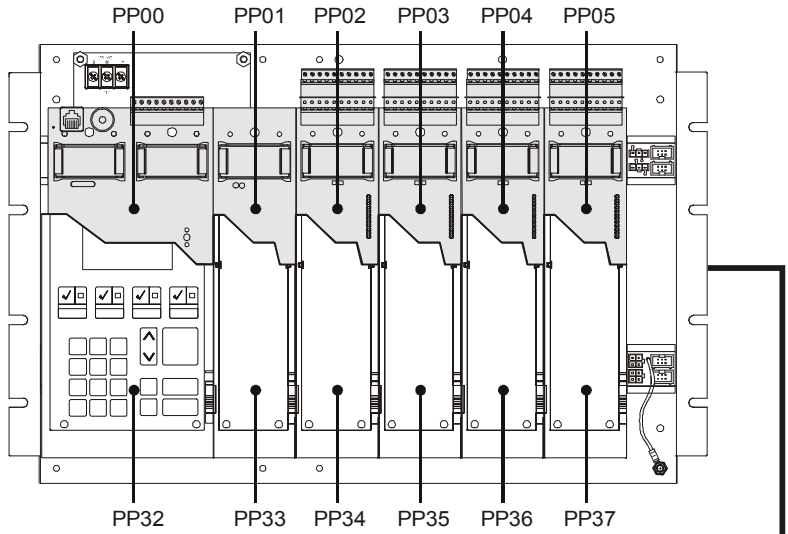

Rail 2
Available in
2- and 3-rail
cabinets

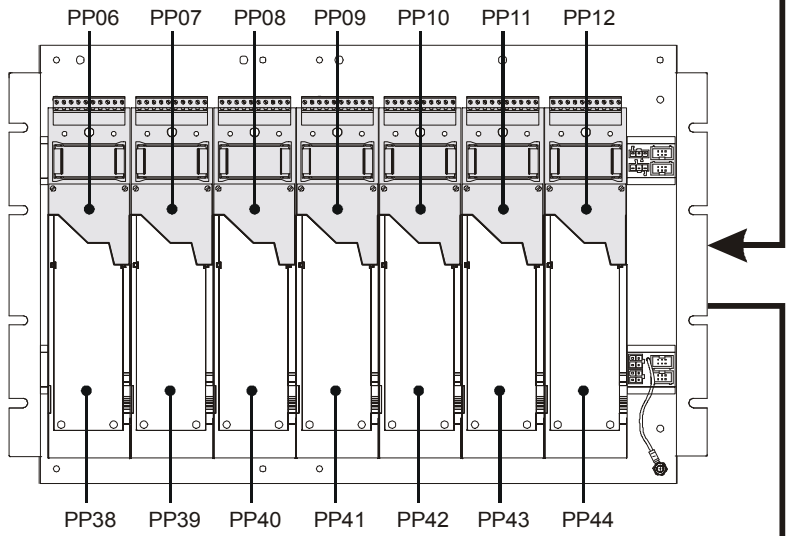

Rail 3
Available only
in 3-rail cabinets

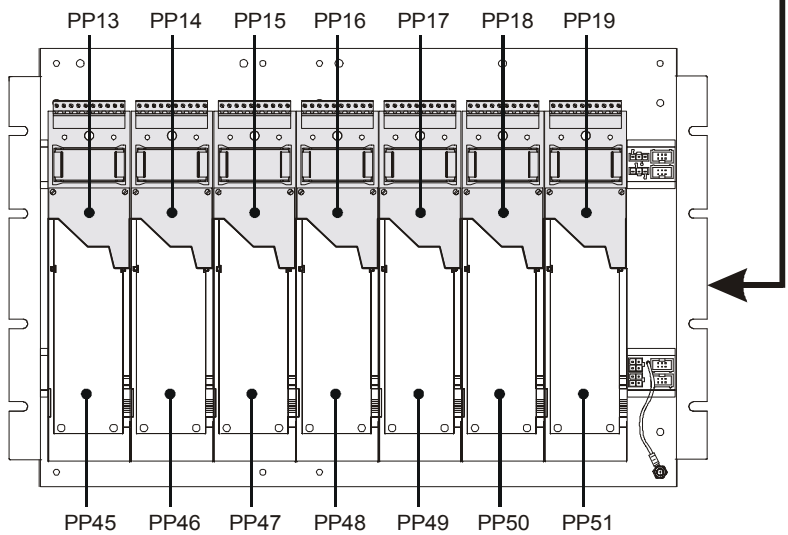

[LRM_ADDR_03.CDR]

Figure A-4: LRM addresses for 3-CHAS7, 3-CHAS7, 3-CHAS7 configuration

System addresses

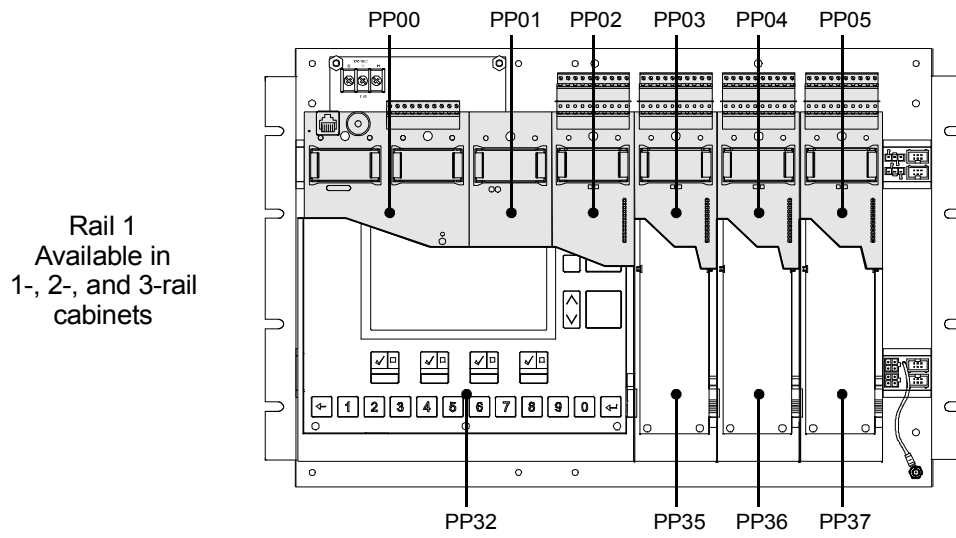
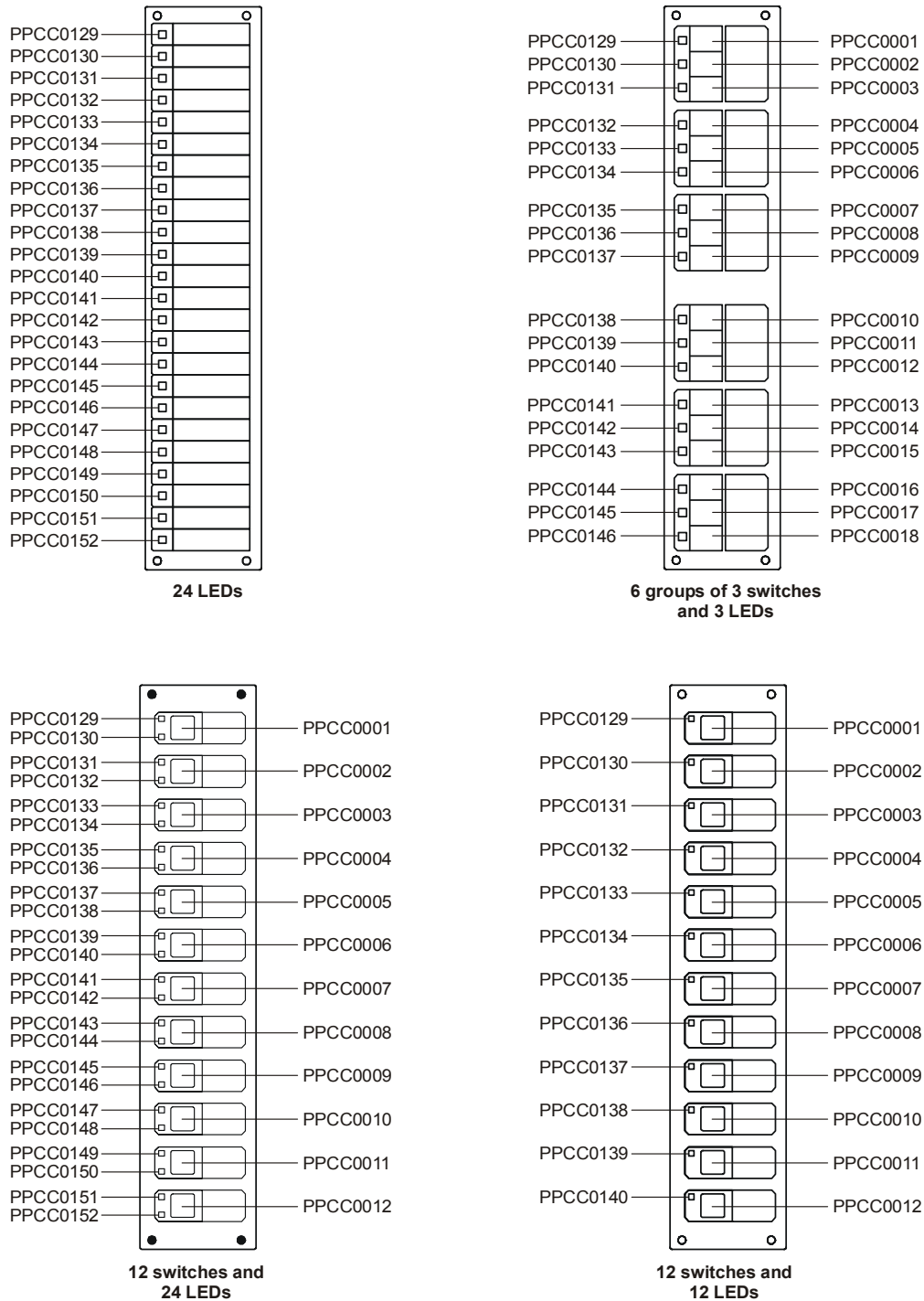

Figure A-5: LRM addresses when using a 3-LCDXL1 Main LCD Display

Control / display module addresses

Figure A-6 shows the device logical addresses that the system assigns the control/display modules.



[DEV_ADDRESS_01.CDR]

Figure A-6: Control/display module switch and LED device addresses

Device addresses

Figure A-7 shows the device logical addresses that the system assigns to various rail modules.

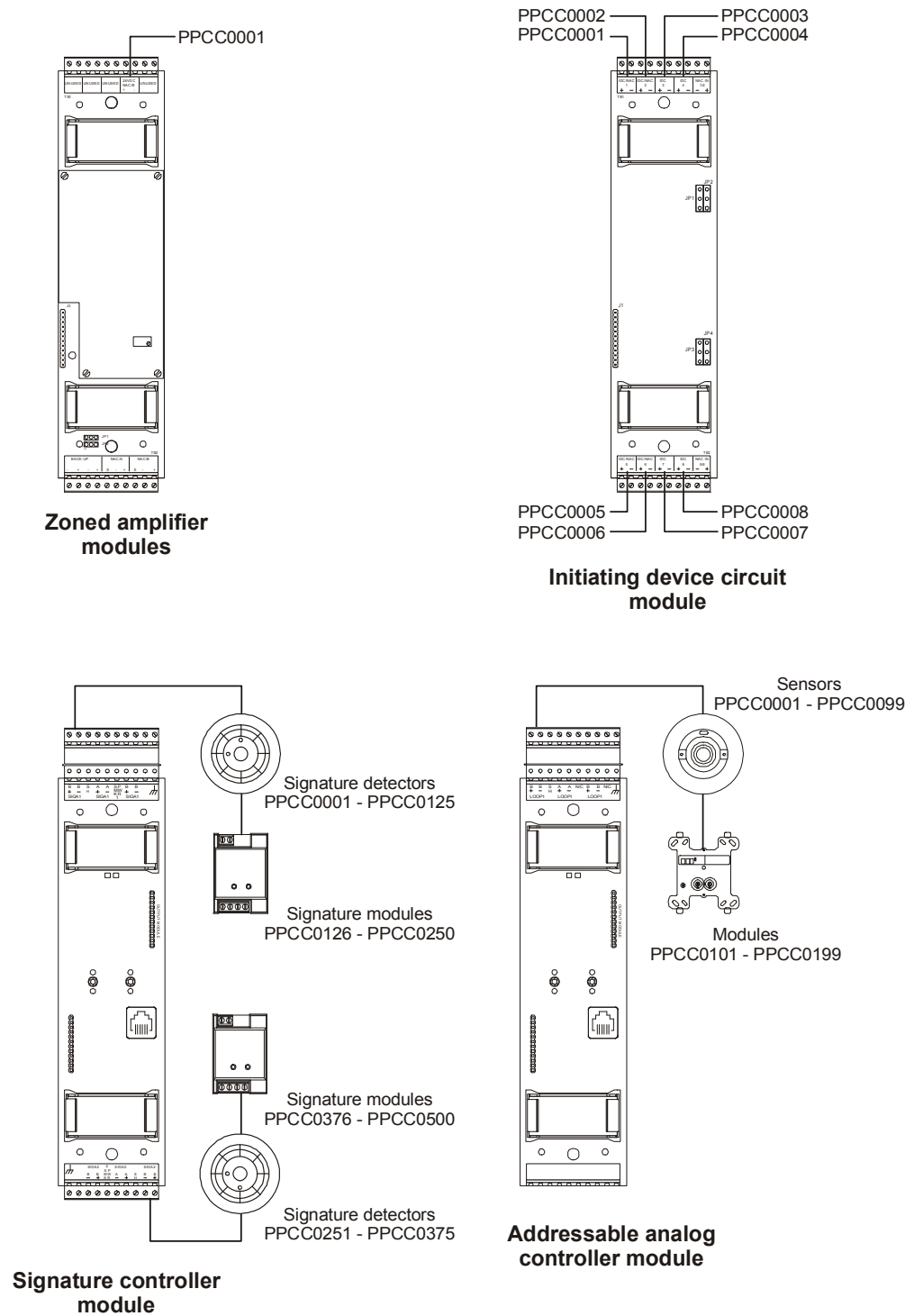

[DEV_ADDRESS_02.CDR]

Figure A-7: Rail module device addresses

System calculations

Summary

This appendix provides worksheets for calculating system parameters, such as wire distance, battery capacity, and memory.

Content

Network data riser limits • B.2

Overview • B.2

Data network specifications • B.2

Cable properties • B.3

Calculating a maximum length • B.3

Calculating maximum wire capacitance per foot • B.4

Signature data circuit wire length • B.5

Determining the maximum allowable branch length • B.5

Determining the total loop length • B.10

Notification appliance circuit calculations • B.11

Introduction • B.11

What you'll need • B.11

Worksheet method • B.13

Equation method • B.14

25 or 70 Vrms NAC wire length • B.17

Addressable analog circuit wire length • B.19

Cabinet battery • B.20

SAC bus power • B.21

Determining the need for a remote power supply • B.21

Providing adequate voltage for devices • B.23

CPU memory • B.26

Fiber optic cable worksheet • B.28

Network data riser limits

Overview

Cumulative data network capacitance refers to the total capacitance of all copper wire used for the data riser. The cumulative capacitance of data networks must be within certain limits to permit stable network communications.

Audio networks are not affected by cumulative capacitance, due to the method of retransmitting data. The audio network retransmits data byte-by-byte, so the individual bit times of a byte are restored at each node in the network.

The data network retransmits data bit-by-bit. This method of retransmitting data restores the amplitude of a bit at each node, but any distortions in bit timing are passed through to the next node. Data network communication faults begin to occur at about 23% distortion of bit timing.

Cumulative data network capacitance induces bit timing distortion.

A fiber link in a data network electrically isolates two nodes, but distortions in bit timing are *not* restored by the fiber segment. Distortions in bit timing are passed through the fiber to the next node. The bit transition time of model 3-FIB fiber cards is fast enough to be neglected in determining the maximum wire length that can be used in the data network.

Data network specifications

Here are the maximum allowed values between any three nodes of a network.

- Resistance: 90 ohms (Ω)
- Capacitance: 0.3 microfarads (μF)
- Distance: 5,000 feet

The following table lists the maximum cumulative capacitance for the entire data network given various wire sizes and transmission rates. *Maximum cumulative capacitance* is the total capacitance of all installed copper wire used in the data network.

Maximum cumulative capacitance in microfarads

Wire size (AWG)	At 38.4 Kbaud	At 19.2 Kbaud
18	1.4	2.8
16	1.8	3.6
14	2.1	4.2

Cable properties

Data and audio networks in an EST3 system do *not* require the use of shielded cable, and networks designed with twisted-pair can be about twice as long as those designed with shielded cable.

The maximum length of a data network varies with the properties of the wire used. Wire manufacturers typically provide specifications for wire resistance and capacitance.

Resistance is generally specified in ohms per 1,000 feet, and must be doubled for 1,000 feet of a twisted-pair cable. Capacitance is specified in picofarads per foot (pF/ft).

The capacitance between conductors of a twisted-pair is commonly referred to as *conductor-conductor* or *mutual* capacitance. Shielded cable has an additional capacitance between each conductor and the shield. The capacitance of either conductor to shield is typically twice the value of mutual capacitance, and the highest value of capacitance must be used when calculating the maximum length of a data network.

The overall length of data networks designed with twisted-pair cable is about twice as long as data networks designed with shielded cable due to the additional capacitance resulting from the shield.

Calculating a maximum length

The maximum length of a data network can be calculated by dividing the maximum cumulative capacitance allowed by the highest capacitance rating of the selected cable.

For example, say you wanted to determine maximum length of a data network using 18 AWG cable that is rated at 25 pF per foot. The network will communicate at 38.4 Kbaud.

The maximum length equals the maximum cumulative capacitance divided by the capacitance per foot. In equation form:

$$ML = MCC / CPF$$

Where:

ML = Maximum length

MCC = Maximum cumulative capacitance

CPF = Capacitance per foot

In our example:

$$ML = 1.4 \mu F / 25 \text{ pF/ft}$$

$$ML = 56,000 \text{ ft}$$

Calculating maximum wire capacitance per foot

The capacitive property of twisted-pair cable varies and the cost of cable generally increases as the capacitance per foot decreases. Following is a sample calculation for determining the maximum capacitance per foot that a cable can have for a given network length.

The maximum capacitance per foot equals the maximum cumulative capacitance divided by the total network length. In equation form:

$$\text{MCPF} = \text{MCC} / \text{TNL}$$

Where:

MCC = Maximum cumulative capacitance, from the table given in this topic

TNL = •Total network length, the sum of the lengths of individual copper runs in the network

Here's an example. The total copper distance of a network is 26,000 feet. Calculate the maximum capacitance per foot that can be used for 18 AWG twisted-pair cable at 38.4K baud.

$$\text{MCPF} = \text{MCC} / \text{TNL}$$

$$\text{MCPF} = 1.4 \mu\text{F} / 26,000 \text{ ft}$$

$$\text{MCPF} = 53.8 \text{ pF/ft}$$

Signature data circuit wire length

Circuit resistance and capacitance determines the maximum length of a Signature data circuit. Circuit resistance affects the wire length of the longest circuit branch. Circuit capacitance affects the total amount of wire that can be used on the circuit.

Notes

The design of the Signature data circuit must not exceed either of the two measurements.

There are no restrictions placed on the wiring used for the Signature data circuit. Longer wire runs may be obtained using standard (non-twisted, non-shielded) wire pairs.

Determining the maximum allowable branch length

The maximum branch length is the wire distance measured from the Signature controller module to the last device on the longest circuit path as shown below.

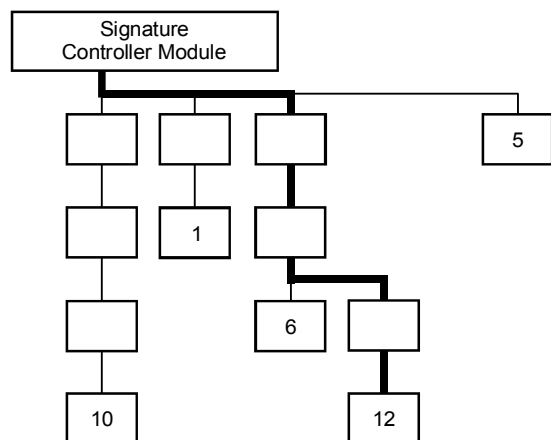

[WIRECALC2.CDR]

Several factors influence the maximum allowable branch length:

- Wire gauge and type
- Number of Signature detectors and modules installed on the branch
- Number of SIGA-UMs configured for 2-wire smoke detectors installed on the branch

Table B-1 through Table B-3 provide the maximum allowable branch length for any detector, module, SIGA-UM, and wire gauge combination. Using the wire distances specified in the tables ensures that the circuit does not exceed the maximum circuit resistance of the Signature data circuit.

Note: To calculate the wire distance with respect to circuit resistance, the tables assume that the circuit is end-loaded (all devices are clustered more towards the end of the circuit) and the circuit uses standard non-shielded wire.

To determine the maximum allowable length of a Signature data circuit branch:

1. Identify the device located farthest from the Signature controller.
2. Determine the number of Signature detectors, modules, and SIGA-UMs configured for 2-wire smokes that lie on the same conductive path between the device identified in step 1 and the Signature controller.
3. Calculate the number of detector and module addresses. Some Signature modules require two addresses.
4. Determine the size of the wire used to construct the circuit.
5. Find the maximum allowable wire distance for the longest branch in the lookup tables as follows:
 - If no SIGA-UMs are installed, use Table B-1.
 - If 1 to 5 SIGA-UMs are installed, use Table B-2.
 - If 6 to 10 SIGA-UMs are installed, use Table B-3.

Table B-1: Maximum branch length with 0 SIGA-UMs configured for 2-wire smokes

Signature detector addresses	Signature module addresses	Maximum allowable wire distance using non-twisted, non-shielded wire pairs					
		18 AWG		16 AWG		14 AWG	
		ft	m	ft	m	ft	m
1–25	0	7437	2267	11815	3601	18792	5728
26–50	0	7038	2145	11180	3408	17782	5420
51–75	0	6638	2023	10545	3214	16772	5112
76–100	0	6238	1901	9910	3021	15762	4804
101–125	0	5839	1780	9275	2827	14752	4497
0	1–25	7267	2215	11544	3519	18361	5597
1–25	1–25	6867	2093	10909	3325	17351	5289
26–50	1–25	6467	1971	10275	3132	16342	4981
51–75	1–25	6068	1849	9640	2938	15332	4673
76–100	1–25	5668	1728	9005	2745	14322	4365
101–125	1–25	5268	1606	8370	2551	13312	4057
0	26–50	6697	2041	10639	3243	16921	5157
1–25	26–50	6297	1919	10004	3049	15911	4850
26–50	26–50	5897	1798	9369	2856	14901	4542
51–75	26–50	5498	1676	8734	2662	13891	4234
76–100	26–50	5098	1554	8099	2469	12881	3926
101–125	26–50	4698	1432	7464	2275	11871	3618
0	51–75	5906	1800	9383	2860	14923	4549
1–25	51–75	5250	1600	8340	2542	13265	4043
26–50	51–75	4633	1412	7360	2243	11707	3568
51–75	51–75	4051	1235	6435	1961	10235	3120
76–100	51–75	3498	1066	5558	1694	8839	2694
101–125	51–75	2973	906	4723	1440	7512	2290
0	76–100	3931	1198	6245	1903	9932	3027
1–25	76–100	3404	1037	5407	1648	8601	2621
26–50	76–100	2899	883	4605	1404	7324	2232
51–75	76–100	2413	735	3833	1168	6096	1858
76–100	76–100	1945	593	3089	942	4913	1498
101–125	76–100	1493	455	2371	723	3771	1149
0	101–125	2631	802	4180	1274	6649	2027
1–25	101–125	2165	660	3439	1048	5470	1667
26–50	101–125	1713	522	2721	829	4328	1319
51–75	101–125	1274	388	2023	617	3218	981
76–100	101–125	847	258	1345	410	2140	652
101–125	101–125	431	131	685	209	1089	332

System calculations

Table B-2: Maximum branch length with 1 to 5 SIGA-UMs configured for 2-wire smokes

Signature detector addresses	Signature module addresses	Maximum allowable wire distance using non-twisted, non-shielded wire pairs					
		18 AWG		16 AWG		14 AWG	
		ft	m	ft	m	ft	m
1-25	0	6778	2066	10768	3282	17126	5220
26-50	0	6131	1869	9741	2969	15492	4722
51-75	0	5501	1677	8739	2664	13899	4236
76-100	0	4885	1489	7760	2365	12342	3762
101-125	0	4282	1305	6802	2073	10819	3298
0	1-25	5353	1632	8504	2592	13525	4122
1-25	1-25	4720	1439	7498	2286	11926	3635
26-50	1-25	4100	1250	6513	1985	10359	3157
51-75	1-25	3491	1064	5546	1691	8821	2689
76-100	1-25	2893	882	4597	1401	7311	2228
101-125	1-25	2306	703	3663	1116	5826	1776
0	26-50	3776	1151	5999	1829	9542	2908
1-25	26-50	3153	961	5009	1527	7966	2428
26-50	26-50	2539	774	4034	1230	6416	1956
51-75	26-50	1935	590	3075	937	4890	1491
76-100	26-50	1340	409	2130	649	3387	1032
101-125	26-50	754	230	1197	365	1905	581
0	51-75	2491	759	3957	1206	6293	1918
1-25	51-75	1868	569	2967	904	4720	1439
26-50	51-75	1254	382	1992	607	3168	966
51-75	51-75	648	198	1030	314	1638	499
76-100	51-75	50	15	80	24	126	39
101-125	51-75						
0	76-100	1386	422	2201	671	3501	1067
1-25	76-100	760	232	1208	368	1921	586
26-50	76-100	143	44	227	69	361	110
51-75	76-100						
76-100	76-100						
101-125	76-100						
0	101-125						
1-25	101-125						
26-50	101-125						
51-75	101-125						
76-100	101-125						
101-125	101-125						

Table B-3: Maximum branch length with 6 to 9 SIGA-UMs configured for 2-wire smokes

Signature detector addresses	Signature module addresses	Maximum allowable wire distance using non-twisted, non-shielded wire pairs					
		18 AWG		16 AWG		14 AWG	
		ft	m	ft	m	ft	m
1-25	0	5045	1538	8015	2443	12748	3886
26-50	0	4494	1370	7139	2176	11355	3461
51-75	0	3950	1204	6275	1913	9981	3042
76-100	0	3414	1040	5423	1653	8625	2629
101-125	0	2884	879	4581	1396	7286	2221
0	1-25	4106	1252	6523	1988	10375	3162
1-25	1-25	3542	1080	5627	1715	8950	2728
26-50	1-25	2985	910	4742	1445	7542	2299
51-75	1-25	2435	742	3868	1179	6152	1875
76-100	1-25	1891	576	3004	916	4778	1456
101-125	1-25	1353	412	2150	655	3419	1042
0	26-50	2869	874	4557	1389	7248	2209
1-25	26-50	2296	700	3648	1112	5802	1768
26-50	26-50	1730	527	2749	838	4372	1332
51-75	26-50	1170	357	1859	567	2957	901
76-100	26-50	617	188	979	299	1558	475
101-125	26-50	68	21	108	33	172	53
0	51-75	1796	547	2853	869	4537	1383
1-25	51-75	1214	370	1929	588	3067	935
26-50	51-75	638	195	1014	309	1613	492
51-75	51-75	69	21	109	33	173	53
76-100	51-75						
101-125	51-75						
0	76-100	833	254	1323	403	2105	642
1-25	76-100	242	74	385	117	613	187
26-50	76-100						
51-75	76-100						
76-100	76-100						
101-125	76-100						
0	101-125						
1-25	101-125						
26-50	101-125						
51-75	101-125						
76-100	101-125						
101-125	101-125						

Determining the total loop length

The total loop length is the sum of the lengths of all the wire segments installed in the data circuit.

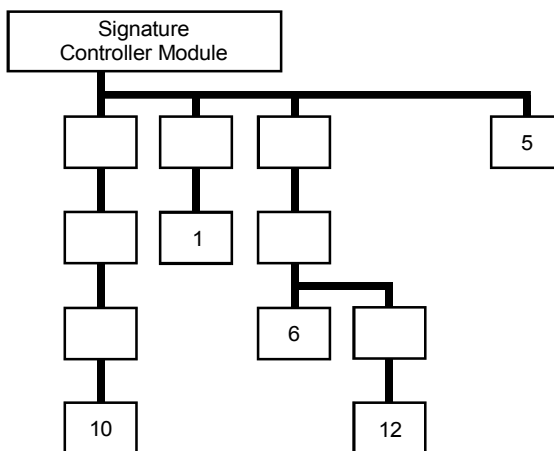

[WIRECALC3.CDR]

The total length of all the cable installed in the Signature data circuit can not exceed the values listed below:

Wire type	Wire Size		
	14 AWG	16 AWG	18 AWG
Twisted pair	13,157 ft (4,010 m)	13,888 ft (4,233 m)	20,000 ft (6,096 m)
Twisted-shielded pair	5,952 ft (1,814 m)	6,098 ft (1,859 m)	8,621 ft (2,628 m)
Non-twisted, non-shielded pair	20,000 ft (6,096 m)	20,000 ft (6,096 m)	20,000 ft (6,096 m)

If the cable manufacturer's data indicates the capacitance per foot of the cable, the following method may be used to determine the maximum total loop length.

Note: In no case may the total loop length of a Signature data circuit exceed 20,000 feet (6,098 meters).

$$L_{max} = 500,000 / C_{pf}$$

where:

- L_{max} = maximum total cable length in feet
- C_{pf} = Cable capacitance in picofarads per foot

Note: A short circuit on a Signature data circuit can disable the entire circuit. In order to limit the effect of a single short circuit on the SDC, SIGA-IB Isolator Bases or SIGA-IM Isolator modules can be installed at strategic points in the circuit.

Notification appliance circuit calculations

Introduction

This topic shows you how to determine the maximum cable length of a notification appliance circuit (NAC) for a given number of appliances.

Two methods are presented: worksheet and equation. The worksheet method is simpler, but your installation must meet the criteria listed on the worksheet. If your installation does not meet these criteria, you need to use the equation method.

The methods given here determine cable lengths that work under all operating conditions. The calculations ensure that the required operating voltage and current will be supplied to all notification appliances. To do this, we assume these two worst-case conditions:

- The voltage at the NAC terminals is the minimum provided by the power supply
- The notification appliances are clustered at the end of the NAC cable

Other, more detailed methods that distribute the appliance load along the NAC cable may indicate that longer cable runs are possible.

What you'll need

Appliance and cable values

Whether you use the worksheet method or the equation method, you'll need to know:

- The minimum operating voltage required for the appliances
- The maximum operating current drawn by each appliance
- The resistance per unit length of the wire used (Ω/ft)

This information can be found on the appliance installation sheets, and on the cable specification sheet.

Power supply values

For either method, you'll need some fixed or calculated operating values for your specific power supply. The fixed values are:

- Maximum voltage = 27.4 V
- Rated voltage = 20.4 V
- Load factor = 0.37 V/A
- Power type = DC

System calculations

The *maximum voltage* is the highest voltage measured at the NAC terminals. This value is not used in the calculations, but is given so you can ensure appliance compatibility.

The *rated voltage* is the theoretical operating minimum for the power supply, and is calculated as 85% of 24 volts.

The *load factor* is a measure of how the power supply voltage reacts when a load is applied. The load factor measures the voltage drop per ampere of current drawn by the load.

The *power type* reflects the type of power supplied to the NAC terminals at minimum voltage. The current draw of notification appliances can vary substantially with the type of power supplied: full-wave rectified (Vfwr) or direct current (Vdc). It is important to know the power type at minimum terminal voltage.

You'll need to calculate the following values relating to your power supply and to the NAC circuit current. These are:

- Minimum voltage
- Voltage drop

The *minimum voltage* is the lowest voltage measured at the NAC terminals when the power supply is under the maximum load for that circuit (i.e. for the appliances that constitute the NAC.)

The *voltage drop* is the difference between the minimum voltage and 16 V. This value is for use with the worksheet only.

Worksheet method

Use this worksheet to determine the maximum cable length of a notification appliance circuit for a given number of appliances.

Use this worksheet only if all the appliances are regulated. That is, they must have a minimum operating voltage of 16 V.

Worksheet 1: NAC cable length

		NAC1	NAC2	NAC3	NAC4	
Total operating current [1]		<input type="text"/>	<input type="text"/>	<input type="text"/>	<input type="text"/>	A
Load factor	×	<input type="text" value="0.37"/>	<input type="text" value="0.37"/>	<input type="text" value="0.37"/>	<input type="text" value="0.37"/>	V/A
Load voltage drop	=	<input type="text"/>	<input type="text"/>	<input type="text"/>	<input type="text"/>	V
Rated voltage		<input type="text" value="20.4"/>	<input type="text" value="20.4"/>	<input type="text" value="20.4"/>	<input type="text" value="20.4"/>	V
Load voltage drop	-	<input type="text"/>	<input type="text"/>	<input type="text"/>	<input type="text"/>	V
Minimum voltage	=	<input type="text"/>	<input type="text"/>	<input type="text"/>	<input type="text"/>	V
Regulated appliance voltage	-	<input type="text" value="16.0"/>	<input type="text" value="16.0"/>	<input type="text" value="16.0"/>	<input type="text" value="16.0"/>	V
Voltage drop [2]	=	<input type="text"/>	<input type="text"/>	<input type="text"/>	<input type="text"/>	V
Total operating current	÷	<input type="text"/>	<input type="text"/>	<input type="text"/>	<input type="text"/>	A
Maximum resistance	=	<input type="text"/>	<input type="text"/>	<input type="text"/>	<input type="text"/>	Ω
Wire resistance (Ω/ft) [3]	÷	<input type="text"/>	<input type="text"/>	<input type="text"/>	<input type="text"/>	
Maximum wire length	=	<input type="text"/>	<input type="text"/>	<input type="text"/>	<input type="text"/>	ft
	÷	<input type="text" value="2"/>	<input type="text" value="2"/>	<input type="text" value="2"/>	<input type="text" value="2"/>	
Maximum cable length	=	<input type="text"/>	<input type="text"/>	<input type="text"/>	<input type="text"/>	ft

[1] Total of the maximum operating currents for all appliances as specified for DC power. See the appliance installation sheets for operating currents.

[2] This voltage drop is valid for regulated notification appliances only. For unregulated appliances, see "Equation method," later in this topic.

[3] Use the manufacturer's published wire resistance expressed in ohms per foot. For typical values, see Table 4, later in this topic.

Equation method

Appliance operating voltage and current

Regulated notification appliances have an operating range from 16 V to 33 V. Use 16 V as the minimum appliance voltage when using regulated notification appliances.

When using unregulated notification appliances, refer to the installation sheets to determine the minimum appliance voltage required.

What if there are different types of appliances in the NAC, and each type has a different minimum operating voltage? In this case, use the *highest* minimum voltage required by any appliance.

The total current requirement for the appliances will be the sum of the individual maximum currents drawn by each appliance when using DC power. Use the maximum current for the appliance over the 16 V to 33 V range.

If all appliances draw the same maximum current, the total current is the maximum current multiplied by the number of appliances. If different appliance types have different maximum currents, the total current is the sum of the maximum current for each appliance type multiplied by the number of appliances of that type.

Wire resistance

Typical wire resistances are shown in the following table.

Table 4: Typical wire resistances

Wire gauge (AWG)	Resistance 1 strand uncoated copper		Resistance 7 strand uncoated copper	
	Ω per foot	Ω per meter	Ω per foot	Ω per meter
12	0.00193	0.00633	0.00198	0.00649
14	0.00307	0.01007	0.00314	0.01030
16	0.00489	0.01604	0.00499	0.01637
18	0.00777	0.02549	0.00795	0.02608

When performing these calculations, always refer to the actual cable supplier documentation and use the actual Ω/ft (or Ω/m) for the cable being used.

Calculating cable length

To calculate the maximum NAC cable length:

1. Calculate the total current (I_{tot}) as the sum of the maximum operating currents for all the appliances.

$$I_{tot} = \sum I_a$$

Where:

I_a = appliance maximum current

See the appliance installation sheets for I_a . Remember to use the maximum operating current specified for DC power.

2. Calculate the minimum voltage (V_m).

$$V_m = V_r - (I_{tot} \times K)$$

Where:

V_r = rated voltage

I_{tot} = total current (from above)

K = load factor

For the power supply, V_r is 20.4 V and K is 0.37 V/A.

3. Calculate the allowable voltage drop (V_d) between the power supply and the appliances.

$$V_d = V_m - V_a$$

Where:

V_m = minimum voltage (from above)

V_a = appliance minimum voltage

For regulated notification appliances, V_a is 16 V. For unregulated notification appliances, V_a is the lowest operating voltage specified on the appliance installation sheet.

4. Calculate the maximum resistance (R_{max}) the wire can have.

$$R_{max} = V_d / I_{tot}$$

Where:

V_d = voltage drop

I_{tot} = total current

5. Calculate the maximum length of the cable (L_c), based on the maximum resistance allowed, the resistance of the wire, and the number of wires in the cable (two).

$$L_c = (R_{max} / R_w) / 2$$

Where:

R_{max} = maximum resistance

R_w = wire resistance factor

Example: You're using regulated notification appliances. Assume that the maximum operating current for each appliance is 100 mA for DC power, and that 20 appliances will be placed on the NAC. The cable is 12 AWG wire, and the manufacturer specifies a wire resistance factor of 0.002 Ω /ft.

$$\begin{aligned} I_{\text{tot}} &= \Sigma I_a \\ &= 20 \times 0.1 \text{ A} \\ &= 2 \text{ A} \end{aligned}$$

$$\begin{aligned} V_m &= V_r - (I_{\text{tot}} \times K) \\ &= 20.4 \text{ V} - (2 \text{ A} \times 0.37 \text{ V/A}) \\ &= 20.4 \text{ V} - 0.74 \text{ V} \\ &= 19.66 \text{ V} \end{aligned}$$

$$\begin{aligned} V_d &= V_m - V_a \\ &= 19.66 \text{ V} - 16.0 \text{ V} \\ &= 3.66 \text{ V} \end{aligned}$$

$$\begin{aligned} R_{\text{max}} &= V_d / I_{\text{tot}} \\ &= 3.66 \text{ V} / 2.0 \text{ A} \\ &= 1.83 \Omega \end{aligned}$$

$$\begin{aligned} L_c &= (R_{\text{max}} / R_w) / 2 \\ &= (1.83 \Omega / 0.002 \Omega/\text{ft}) / 2 \\ &= (915 \text{ ft}) / 2 \\ &= 457.5 \text{ ft} \end{aligned}$$

So the maximum wire run for this NAC would be 457 ft (rounding down for safety).

25 or 70 Vrms NAC wire length

The maximum allowable wire length is the farthest distance that a pair of wires can extend from the amplifier to the last speaker on the notification appliance circuit without losing more than 0.5 dB of signal. Calculating the maximum allowable wire length using this method ensures that each speaker operates at its full potential.

Several factors influence the maximum allowable wire length:

- Wire size
- Output signal level of the amplifier driving the circuit
- Number of speakers installed on the circuit

To calculate the maximum allowable wire length for a 0.5 dB loss, use the following formula:

$$\text{Max length} = \frac{59.25 \times \text{Amplifier output}^2}{\text{Wire resistance} \times \text{Circuit load}}$$

where:

- Amplifier output is the signal level in Vrms supplied by the amplifier driving the circuit
- Circuit load is the total watts required by the audio circuit
- Wire resistance is the resistance rating of the wire per 1000 ft pair, see Table B-5.

For example, the maximum allowable wire length for an audio circuit consisting of a 30 W, 25 Vrms amplifier driving thirty 1-watt speakers, using 18-gauge wire would be 95 ft.

$$94.95 = \frac{59.25 \times 25^2}{13 \times 30}$$

Table B-5: Wire resistance ratings

Wire Size	Resistance per 1,000 ft pair (ohms)
18 AWG (0.75 sq mm)	13.0
16 AWG (1.0 sq mm)	8.0
14 AWG (1.50 sq mm)	5.2
12 AWG (2.5 sq mm)	3.2

Table B-6 and Table B-7 give the maximum allowable wire lengths for various wire sizes and loads. Use Table B-6 when designing circuits for amplifiers set for 25 Vrms output. Use

Table B-7 when designing circuits for amplifiers set for a 70 Vrms output.

Table B-6: Maximum allowable length at 25 Vrms, 0.5 dB loss

Wire size	Circuit load requirement											
	15 W		20 W		30 W		40 W		95 W		120 W	
	ft	m	ft	m	ft	m	ft	m	ft	m	ft	m
18 AWG (0.75 sq mm)	190	58	142	43	95	29	71	22	Over max current limit		Over max current limit	
16 AWG (1.0 sq mm)	309	94	231	70	154	47	116	35	48.7	15	39	12
14 AWG (1.5 sq mm)	475	145	356	109	237	72	178	54	75	23	59	18
12 AWG (2.5 sq mm)	772	235	579	176	386	118	289	88	121.8	37	96	29

Table B-7: Maximum allowable length at 70 Vrms, 0.5 dB loss

Wire size	Circuit load requirement											
	15 W		20 W		30 W		40 W		95 W		120 W	
	ft	m	ft	m	ft	m	ft	m	ft	m	ft	m
18 AWG (0.75 sq mm)	1489	454	1117	340	744	227	558	170	235	72	186	57
16 AWG (1.0 sq mm)	2420	738	1815	553	1210	369	907	276	382	116	302	92
14 AWG (1.5 sq mm)	3722	1134	2792	851	1861	567	1396	426	588.7	180	465	142
12 AWG (2.5 sq mm)	6049	1844	4537	1383	3024	922	2268	691	955	291	756	230

Addressable analog circuit wire length

Table B-8 lists the maximum wire distances allowed for Addressable Analog circuits.

Notes

Maximum wire resistance can not exceed 50 ohms.

Maximum wire capacitance can not exceed 0.05 microfarads.

Table B-8: Maximum allowable wire distance for Addressable Analog circuits

Wire gauge	Max loop Capacitance	Twisted, non-shielded		Twisted, shielded		Non-twisted, non-shielded	
		ft	m	ft	m	ft	m
18	0.01 μ F	4000	1219	1724	525	5000	1524
	0.02 μ F	8000	2438	3448	1051	10000	3048
	0.03 μ F	12000	3658	5172	1576	15000	4572
	0.04 μ F	16000	4877	6896	2102	20000	6096
	0.05 μ F	20000	6096	8620	2627	25000	7620
16	0.01 μ F	2777	846	1219	372	5000	1524
	0.02 μ F	5555	1693	2439	743	10000	3048
	0.03 μ F	8333	2540	3658	1115	15000	4572
	0.04 μ F	11111	3387	4878	1487	20000	6096
	0.05 μ F	13888	4233	6097	1858	25000	7620
14	0.01 μ F	2631	802	1190	363	5000	1524
	0.02 μ F	5263	1604	2380	725	10000	3048
	0.03 μ F	7894	2406	3571	1088	15000	4572
	0.04 μ F	10526	3208	4761	1451	20000	6096
	0.05 μ F	13157	4010	5952	1814	25000	7620

Cabinet battery

Use the following method to calculate the minimum ampere-hour capacity of a battery required in order to operate a panel in the absence of AC power. Battery calculations must be performed separately for each cabinet in the system.

Determine the total amount of current in milliamps required by all of the components that derive power from the battery while the panel is in standby mode. Multiply the total amount of standby current by the number of hours that the panel is required to operate in standby mode while on battery power.

Determine the total amount of current in milliamps required by all of the components that derive power from the battery while the panel is in alarm mode. Multiply the total amount of alarm current by the number of minutes that the panel is required to operate in alarm mode while on battery power. Divide the result by 60 to convert minutes to hours.

Add the total amount of standby current and the total amount of alarm current then divide the result by 1000 to convert to ampere-hours. Multiply this number by 1.2 to add a 20% safety factor to the calculations.

EST3 is UL Listed for battery operation durations as follows:

- Standby: 60 hours max.
- Alarm: 30 minutes max.

SAC bus power

This topic provides information to help you determine whether:

A power supply must be added to the SAC bus

Adequate voltage will be available to CRCs and KPDISPs on the SAC bus

The standby battery in each CRC is properly sized

Determining the need for a remote power supply

The need for additional power is dictated by the current drawn by the devices on the SAC bus. Each 3-PPS/M can supply a total of 7 A through two 3.5 A outputs. Each SAC line can therefore draw a maximum of 3.5 A. This consists of the current drawn by the CRCs and KPDISPs plus any readers, strikes, or maglocks.

If the load on the 3-PPS/M supply is greater than 3.5 A, you'll need to split the devices over two SAC busses, or add a remote power supply.

To determine the total load on the 3-PPS/M:

1. Complete Form A (below) to calculate the system alarm and standby load current.
2. Total the columns to determine the Total Alarm Load and Total Amp Hours. These two totals will be used in later calculations.
3. If the Total Alarm Load is greater than 3.5 A, the devices must be divided between two SAC busses, each with a separate supply—OR—a remote power supply must be installed.

System calculations

Form A: 3-SAC alarm and standby load

Device	Qty	Alarm current (mA)	Total alarm current (mA)	Standby current (mA)	Total standby current (mA)	Standby time (Hours)	Amp hours (mAH)
KPDISP		100		35			
CRC		950		940			
CR-5355		72		70			
CR-5365		31		25			
CR-5395		24		20			
CR-6005		20		20			
Reader sounder		8		0			
CRCSND		8		0			

Strike rating

100 mA @ 12 V	33		0			
150 mA @ 12 V	40		0			
200 mA @ 12 V	42		0			
250 mA @ 12 V	47		0			
300 mA @ 12 V	51		0			
35 mA @ 12 V	55		0			
400 mA @ 12 V	58		0			
450 mA @ 12 V	63		0			
500 mA @ 12 V	65		0			

Maglock rating

100 mA @ 12 V	80		80			
150 mA @ 12 V	126		126			
200 mA @ 12 V	156		156			
250 mA @ 12 V	187		187			
300 mA @ 12 V	233		233			
350 mA @ 12 V	283		283			
400 mA @ 12 V	376		376			
450 mA @ 12 V	436		436			
500 mA @ 12 V	470		470			

Total alarm load (must be < 3.5 A)

Total amp hours (Battery)

Note: Standby time = length of time that the device will draw standby current from battery. There is no minimum standby time for access control.

Providing adequate voltage for devices

To determine whether each CRC and KPDISP will have adequate input voltage, calculate the voltage drops along the SAC bus. Voltage drops can be estimated or actual.

Estimated voltage drop

To estimate the voltage drop use Table B-9 and Table B-10, which show the maximum wire length for a given number of doors at a given current load. The tables assume even spacing between the doors and an equal load at each door.

1. First, determine the load per door by adding the alarm currents of the CRC, door lock, card reader, and sounder.
2. Determine the number of doors you need to secure. Find the number of doors Table B-9 then search across that row for the column with the current you calculated in step 1.
3. The intersection gives the maximum distance from the 3-PPS/M or remote power supply to the last door.
4. If the distance to the last door in your installation is less than this distance no further calculations are needed.
5. If the distance to the last door in you installation is greater than this distance check Table B-10 using steps 1 through 4.
6. If changing the gauge of the wire does not work, you must run a second power line, or divide the SAC bus and add a remote power supply. In either case, recheck your estimates.

For example: You are putting a CRC, a strike rated at 250 mA @ 12 Vdc, a CR-5395 and a CRCSND at 8 doors. The furthest door is 500 feet from the control.

Using step 1 above, you determine that the total alarm current for this door is 149 mA. In Table B-9 (for 16 AWG), find 8 in the Doors column, go across this row to the 150 mA column. The intersection shows a maximum length of 584 feet. Since the distance from the control panel to the last door is less than 584 feet, no further calculations are needed.

Actual voltage drop

To calculate the actual voltage drop based on the actual load for each device and the actual distance between each device, follow these steps:

1. Start the EST3 System Builder and select the 16 AWG check box.
2. Enter the actual alarm load for the first device and the distance from the control panel to that device. The system will calculate the voltage drop and indicate whether it is OK to continue.

System calculations

3. Continue by adding the actual alarm load and the distance from the previous device for each device on the SAC bus.
4. If you successfully enter all devices with no error messages, no further calculations are required. The panel supply will be adequate and each device will receive sufficient voltage.
5. If an error message occurs, you have the following options:
 - Repeat the process using 14 AWG in step 1
 - Run a second power supply line
 - Divide the SAC bus and add a remote power supply

SAC bus wire length tables

Table B-9: SAC bus wire length for number of doors vs. current loads using 16 AWG wire

Doors	Load (mA)												
	70	100	150	200	250	300	350	400	450	500	550	600	650
1	4000	4000	2650	2000	1600	1300	1140	1000	885	800	720	665	616
2	3800	2660	1776	1300	1060	880	760	666	594	532	484	444	410
3	2850	1950	1320	990	780	660	570	498	444	399	363	333	306
4	2240	1600	1040	800	624	520	452	400	355	320	288	266	244
5	1875	1350	885	650	525	435	375	333	296	266	242	222	205
6	1620	1140	756	558	450	378	324	286	254	228	207	190	X
7	1400	980	665	497	392	329	285	250	222	199	X	X	X
8	1240	880	584	440	352	288	253	222	197	X	X	X	X
9	1125	810	522	396	315	261	228	200	X	X	X	X	X
10	1030	730	480	360	290	240	207	X	X	X	X	X	X
11	946	660	440	330	264	220	X	X	X	X	X	X	X
12	876	600	408	300	240	X	X	X	X	X	X	X	X
13	806	559	377	273	X	X	X	X	X	X	X	X	X
14	756	518	350	X	X	X	X	X	X	X	X	X	X
15	705	495	330	X	X	X	X	X	X	X	X	X	X
16	672	464	304	X	X	X	X	X	X	X	X	X	X
17	629	442	X	X	X	X	X	X	X	X	X	X	X
18	576	414	X	X	X	X	X	X	X	X	X	X	X
19	570	399	X	X	X	X	X	X	X	X	X	X	X
20	540	380	X	X	X	X	X	X	X	X	X	X	X

Note: All distance measurements given in feet. X means that the 3-PPS/M will not support these devices at any distance.

Table B-10: SAC bus wire length for number of doors vs. current loads using 14 AWG wire

Doors	Load (mA)												
	70	100	150	200	250	300	350	400	450	500	550	600	650
1	4000	4000	4000	3000	2400	2000	1750	1500	1360	1200	1100	1000	940
2	4000	4000	2700	2000	1600	1360	1160	1000	900	800	740	680	620
3	4000	3000	2040	1500	1200	1020	870	750	660	600	555	510	471
4	3480	2400	1600	1200	960	800	700	600	544	480	436	400	376
5	2900	2000	1365	1000	800	675	575	500	455	405	365	335	315
6	2460	1710	1140	870	690	582	492	438	390	348	312	X	X
7	2170	1505	1015	756	602	511	434	378	336	301	X	X	X
8	1920	1360	904	680	544	448	384	336	X	X	X	X	X
9	1710	1215	810	612	477	405	351	X	X	X	X	X	X
10	1550	1100	740	550	440	370	310	X	X	X	X	X	X
11	1430	1012	682	506	407	341	X	X	X	X	X	X	X
12	1344	936	624	468	372	X	X	X	X	X	X	X	X
13	1248	858	585	429	351	X	X	X	X	X	X	X	X
14	1162	812	532	406	322	X	X	X	X	X	X	X	X
15	1095	750	510	375	X	X	X	X	X	X	X	X	X
16	1024	720	480	352	X	X	X	X	X	X	X	X	X
17	969	680	442	340	X	X	X	X	X	X	X	X	X
18	918	630	414	X	X	X	X	X	X	X	X	X	X
19	874	608	399	X	X	X	X	X	X	X	X	X	X
20	820	580	380	X	X	X	X	X	X	X	X	X	X

Note: All distance measurements given in feet. X means that the 3-PPS/M will not support these devices at any distance.

CPU memory

Use the CPU memory calculation worksheet, Table B-11, to determine if a CPU requires additional memory. Each line in the worksheet is a system variable and is referenced by a line identification (ID) letter. The line IDs also appear in the formula column. The result of solving a formula is then placed in the “Results” column.

Enter the values for each variable in the “#” column on the same line.

Replace the variables in the formula by the value entered in the “#” column having the same letter as the formula.

Calculate the formula and put the results in the “Results” column.

Determine the memory size required as indicated at the bottom of the worksheet.

Note: The Systems Definition Utility will prevent you from downloading if the compiled project database exceeds the amount of memory on the CPU.

Table B-11: CPU memory calculation worksheet

Line	Variable	#	Formula	Result
A	Base usage	N/A	N/A	70,000
B	Label usage	N/A	$48 + (22 \times (H + K + L + N + Q + S + T))$	
C	Average number of characters in a message		Between 0 and 42	
D	Average number of characters in a rule		Between 4 and 10 per controlled output	
E	Number of routing definitions		$2 + (E \times 8)$	
F	Number of rail modules other than Signature controller modules		$F \times 916$	
G	Number of Signature controller modules		$G \times 1,776$	
H	Number of zones		$H \times (22 + C + (J \times 4) + (D \times 2))$	
J	Average number of devices in typical zone		N/A	
K	Number of Service groups		$K \times (14 \times C + (2 \times D))$	
L	Number of AND groups		$L \times (22 + C + (D \times 2) + (M \times 4))$	
M	Average number of devices in AND Group		N/A	
N	Number of Matrix groups		$N \times (22 + C + (2 \times D) + (4 \times P))$	
P	Average number of devices in a Matrix Group		N/A	
S	Number of time controls		$S \times ((26 + C) + (2 \times D) + 14)$	
T	Number of Guard Patrols		$T \times (22 + C + (V \times 4) + (U \times 4))$	
U	Number of Guard Patrol routes		N/A	
V	Number of Guard Patrol stations		N/A	
W	Number of physical devices		$W \times (46 + C + (Y \times 4) + (2 \times D) + 8)$	
Y	Average number of Logics per device		N/A	
Z	Sum of Results Lines A to Y		$A + B + C + D + E + F + G + H + J + K + L + M + N + P + S + T + U + V + W + Y$	

If result on line Z is less than 262,144, no additional memory is required.

If result on line Z is greater than 500,000 then enter the job in 3-SDU to determine the exact size requirement (size of CABxx.bin file).

If result on line Z is still greater than 500,000 reduce the number of points on the panel, for example, by splitting the panel into two panels.

Fiber optic cable worksheet

The fiber optic cable worksheet should be used to verify that the light attenuation factors do not exceed the fiber optic budget for any fiber optic cable segment.

Notes

The contractor installing the fiber optic cable provides items A, B, and D.

Fiber optic budget must be greater than the total link loss (F).

Table B-12: Fiber Optic Cable Worksheet

Link Name	A Cable loss per unit distance [] dB/Ft [] dB/Km [] dB/Mi	B Distance [] Feet [] Km [] Miles	C Cable Loss A x B	D Number of Splices	E Contingency Splices	F Total Link Loss (dB) C+2[D+E]

Summary

This appendix describes the requirements your EST3 system must meet in order to conform to UL or ULC listings.

Content

- NFPA standards • C.2
- Minimum requirements for UL security applications • C.3
 - Local mercantile premises • C.3
 - Police station connection using a 3-MODCOM or FireWorks • C.3
 - Central station connection using FireWorks • C.4
 - Central station with local bell timeout using a 3-MODCOM • C.5
 - Central station using a 3-MODCOM • C.6
 - Proprietary using 3-MODCOM or FireWorks • C.7
 - Proprietary with standard line security • C.7
 - Access control • C.8
 - Holdup alarm • C.8
- UL and ULC requirements • C.10

NFPA standards

EST3 meets the requirements of NFPA 72 for Local, Auxiliary, Remote Station, Proprietary, and Emergency Voice/Alarm fire systems.

Minimum requirements for UL security applications

Local mercantile premises

Standard: UL 609

Minimum hardware:

- 3-RCC7 Remote Closet Cabinet
- ATCK Attack Kit
- 3-TAMPRCC Cabinet Tamper Switch
- Central Processor Unit (CPU)
- 3-PPS/M Primary Power Supply
- Main LCD Display (LCD)
- or—
- KPDISP Keypad Display
- 3-SAC Security Access Module
- Signature Controller Module
- Listed bell and bell housing: Ademco model AB12M Bell in Box
- 24DC12 12 Vdc Voltage Regulator with Security Bell Interface
- 3-IDC8/4 Traditional Zone I/O Module
- SIGA-MD Motion Detector
- SIGA-SEC2 Security Loop Module

Additional requirements:

- Standby power must provide 24 hours of standby with 15 minutes of alarm
- Maximum entry or exit delay must be 60 seconds
- Bell test must be included in system programming, if not a built-in feature of the software
- System must be programmed for a minimum of 15 minutes bell ring on alarm
- System must be programmed to indicate bell timeout with an LED
- System power supply, bell power supply (24DC12), and bell monitoring module (IDC8/4), must all be inside the ATCK Attack Kit protected cabinet

Police station connection using a 3-MODCOM or FireWorks

Standard: UL 365

Minimum hardware:

- 3-RCC7 Remote Closet Cabinet
- ATCK Attack Kit
- 3-TAMPRCC Cabinet Tamper Switch

Listing requirements

- Central Processor Unit (CPU)
- 3-PPS/M Primary Power Supply
- Main LCD Display (LCD)
—or—
KPDISP Keypad Display
- 3-MODCOM Modem Communication Module
—or—
FireWorks
- 3-SAC Security Access Module
- Signature Controller Modules
- Listed bell and bell housing: Ademco model AB12M Bell in Box
- 24DC12 12 Vdc Voltage Regulator with Security Bell Interface
- 3-IDC8/4 Traditional Zone I/O Module
- SIGA-MD Motion Detector
- SIGA-SEC2 Security Loop Module

Additional requirements:

- Standby power must provide 24 hours of standby with 15 minutes of alarm
- Maximum entry or exit delay must be 60 seconds
- System must be programmed for a minimum of 15 minutes bell ring on alarm
- System must be programmed to indicate bell timeout with an LED
- System power supply, bell power supply (24DC12), and bell monitoring module (IDC8/4), must all be inside the ATCK Attack Kit protected cabinet
- Systems using a 3-MODCOM must be configured using two phone lines with line-cut detection
—or—
a single line with 24-hour test
- System must be programmed to provide closing confirmation (ring-back) at the arming station

Central station connection using FireWorks

Standard: UL 1610

Minimum hardware:

- 3-RCC7 Remote Closet Cabinet
- ATCK Attack Kit
- 3-TAMPRCC Cabinet Tamper Switch
- Central Processor Unit (CPU)
- 3-PPS/M Primary Power Supply
- Main LCD Display (LCD)

—or—

KPDISP Keypad Display

- FireWorks
- 3-SAC Security Access Module
- Signature Controller Modules
- SIGA-MD Motion Detector
- SIGA-SEC2 Security Loop Module

Additional requirements:

- System must be connected to a FireWorks workstation
- Standby power must provide 24 hours of standby with 15 minutes of alarm
- Maximum entry or exit delay must be 60 seconds
- System must be programmed to transmit opening and closing messages to the central monitoring station
- System must be programmed to provide closing confirmation (ring-back) at the arming station

Central station with local bell timeout using a 3-MODCOM

Standard: UL 1610

Minimum hardware:

- 3-RCC7 Remote Closet Cabinet
- ATCK Attack Kit
- 3-TAMPRCC Cabinet Tamper Switch
- Central Processor Unit (CPU)
- 3-PPS/M Primary Power Supply
- Main LCD Display (LCD)

—or—

KPDISP Keypad Display

- 3-MODCOM Modem Communication Module
- 3-SAC Security Access Module
- Signature Controller Module
- Listed bell and bell housing: Ademco model AB12M Bell in Box
- 24DC12 12 Vdc Voltage Regulator with Security Bell Interface
- 3-IDC8/4 Traditional Zone I/O Module
- SIGA-MD Motion Detector
- SIGA-SEC2 Security Loop Module

Additional requirements:

- Standby power must provide 24 hours of standby with 15 minutes of alarm
- Maximum entry or exit delay must be 60 seconds

Listing requirements

- System must be programmed for a minimum of 15 minutes bell ring on alarm
- System must be programmed to indicate bell timeout with an LED
- System power supply, bell power supply (24DC12), and bell monitoring module (IDC8/4), must all be inside the ATCK Attack Kit protected cabinet
- System must be programmed to transmit opening and closing messages to the central monitoring station
- System must be configured using two phone lines with line-cut detection *or* a single line with 24-hour test
- System must be programmed to provide closing confirmation (ring-back) at the arming station

Central station using a 3-MODCOM

Standard: UL 1610

Minimum hardware:

- 3-RCC7 Remote Closet Cabinet
- ATCK Attack Kit
- 3-TAMPRCC Cabinet Tamper Switch
- Central Processor Unit (CPU)
- 3-PPS/M Primary Power Supply
- Main LCD Display (LCD)
—or—
KPDISP Keypad Display
- 3-MODCOM Modem Communication Module
- 3-SAC Security Access Module
- Signature Controller Modules
- SIGA-MD Motion Detector
- SIGA-SEC2 Security Loop Module

Additional requirements:

- Standby power must provide 24 hours of standby with 15 minutes of alarm
- Maximum entry or exit delay must be 60 seconds
- System must be programmed to transmit opening and closing messages to the central monitoring station
- System must be configured using two phone lines with line-cut detection
—or—
3-RCC7 a single line with 24-hour test
- System must be programmed to provide closing confirmation (ring-back) at the arming station

Proprietary using 3-MODCOM or FireWorks

Standard: UL 1076

Minimum hardware:

- 3-RCC7 Remote Closet Cabinet
- ATCK Attack Kit
- 3-TAMPRCC Cabinet Tamper Switch
- Central Processor Unit (CPU)
- 3-PPS/M Primary Power Supply
- Main LCD Display (LCD)
—or—
KPDISPKeypad Display
- 3-MODCOM Modem Communication Module
—or—
FireWorks
- 3-SAC Security Access Module
- Signature Controller Modules
- SIGA-MD Motion Detector
- SIGA-SEC2 Security Loop Module

Additional requirements:

- Standby power must provide 24 hours of standby with 15 minutes of alarm
- Maximum entry or exit delay must be 60 seconds
- Systems using a 3-MODCOM must be configured using two phone lines with line-cut detection
—or—
a single line with 24-hour test
- System must be programmed to provide closing confirmation (ring-back) at the arming station

Proprietary with standard line security

Standard: UL 1076

Minimum hardware:

- 3-CAB5, 3-CAB7, 3-CAB14, 3-CAB21, 3-RCC7, 3-RCC14, or 3-RCC21 with 3-CHAS7
- 3-TAMP, 3-TAMP5, or 3-TAMPRCC Cabinet Tamper Switch
- Central Processor Unit (CPU)
- 3-PPS/M Primary Power Supply
- 3-IDC8/4
—or—
3-SSDC(1) or 3-SDDC(1) with SIGA-CT1, SIGA-CT2, or SIGA-UM
- 3-RS485A, 3-RS485B, or 3-RS485R

Additional requirements:

Listing requirements

- Standard line security is for stand-alone or networked EST3 systems only

Access control

Standard: UL 294

Minimum hardware:

- Central Processor Unit (CPU)
- 3-PPS/M Primary Power Supply
- Main LCD Display (LCD)
- 3-SAC Security Access Module
- CRC or CRCXM Card Reader Controller

Note: The CRC or CRCXM Card Reader Controller is fully functional and does not require a supportive PC for access decisions. Refer to the *CRC and CRCXM - Card Reader Controller Installation Sheet*.

Holdup alarm

Standard: UL 636

Minimum hardware:

- 3-RCC7 Remote Closet Cabinet
- ATCK Attack Kit
- 3-TAMPRCC Cabinet Tamper Switch
- Central Processor Unit (CPU)
- 3-PPS/M Primary Power Supply
- Main LCD Display (LCD)
- 3-MODCOM Modem Communication Module
—or—
FireWorks
- 3-IDC8/4 Traditional Zone I/O Module
—or—
Signature Controller Module
—plus—
SIGA-CT1, SIGA-CT2, or SIGA-UM module
- Listed compatible holdup IDC devices

Additional requirements:

- Standby power must provide 24 hours of standby with 15 minutes of alarm
- Maximum entry or exit delay must be 60 seconds
- Systems using a 3-MODCOM must be configured using two phone lines with line-cut detection
—or—
a single line with 24-hour test
- IDC8/4 devices must be configured as a security zone (in the SDU, Hard Zone Type = SECURITY)

- Signature modules must be configured as security devices (in 3-SDU, Device Type = Active Latching > Security)
- IDC8/4 devices must be configured so Routing Label and Alternate Routing Label are set to *No_Cabinets* (that is, the holdup event messages must not be displayed on any panel or other annunciator device)
- The system must be programmed so that all local outputs are suppressed.
- SIGA-CT1, SIGA-CT2, and SIGA-UM module loops used for holdup must be configured so Routing Label and Alternate Routing Label are set to *No_Cabinets* (that is, the holdup event messages must not be displayed on any panel or other annunciator device)
- The central monitoring station or FireWorks workstation must be manned on a 24-hour basis

The following material is extracted from UL 636, Section 86. It applies to Holdup alarm applications.

86 Types of Remote Stations

86.1 A holdup alarm signal shall be transmitted to one of the following remote stations:

- a) Direct to a constantly manned police department equipped for broadcasting radio calls to cruising squad cars or to a central station or residential monitoring station with facilities for relaying calls to a police department with such broadcasting facilities. The central station shall comply with the Standard for Central-Station Burglar Alarm Systems, UL 611, or the Standard for Central-Stations for Watchman, Fire Alarm and Supervisory Services, UL 827. The residential monitoring station shall comply with UL 611, UL 827, or both.
- b) Two or more private stations in places of business constantly open during the day, located within 500 feet (152 m) of the protected premises and commanding all public approaches to the premises.

UL and ULC requirements

The following table describes the requirements your system must meet in order to conform to UL or ULC.

UL	ULC	Requirement
X	X	<p>Partitioned security systems with central monitoring station reporting</p> <p>A partition that contains an EST3 panel equipped with a 3-MODCOM and local bell must be armed 24 hours a day, and have limited, high-level access.</p> <p>When FireWorks is used as the central monitoring station, the EST3 panel to which it connects must be in a partition that is armed 24 hours a day, and has limited, high-level access.</p> <p>Closing confirmation (ring back) must be provided at all arming stations. Use of multiple sounders or bells is acceptable.</p>
X	X	<p>Partitioned security systems using local bells</p> <p>A local bell must be positioned where it can be heard at each arming station. Use of multiple bells is acceptable.</p> <p>The system must be programmed to sound the bell for a minimum of 15 minutes on alarm. If the bell stops sounding after 15 minutes (timeout), the system must be programmed to light an LED to indicate bell timeout.</p> <p>When using a 24DC12 module to power the bell, that module must be installed in an EST3 cabinet that has a 3-TAMPRCC Cabinet Tamper Switch and an ATCK Attack Kit.</p>
X	X	<p>Partitioned security systems for certification</p> <p>All partitions in a certificated partitioned access control or security system must be under the control of a single company.</p> <p>In a certificated system, each separately owned business must have its own security system.</p>
X	X	<p>Security systems</p> <p>All security systems must specify a master arming station which receives all security event messages. Alternately, the system may be configured so that all messages are routed to all keypads.</p> <p>All cabinets in a system that includes security functionality must include tamper switches.</p> <p>On activation, all security points must generate an appropriate output device response. The SDU cannot guarantee correlation between security input devices and output devices. The system programmer must ensure that all points are accounted for. When the system includes a bell, you should create a general rule to sound the bell on activation of any security device.</p>
X	X	<p>Panel programming</p> <p>Fire and security functionality cannot be programmed into a control panel from a remote location. You must perform all panel programming on site.</p>

A device or zone	An alarm device or zone
ACDB	Access Control Database program. Software that lets end users create and maintain an access control database. The program communicates with the system either by direct RS-232 connection, or by telephone lines to a 3-MODCOM.
activate	To turn on or energize. Pertains to outputs (including logical outputs).
address	A number used to uniquely identify a device, output, panel, etc. within an EST3 system
alarm	The state of a fire alarm initiating device that has detected a smoke or fire condition. The state of a security device that has been triggered.
alarm silence timer	A panel option that automatically silences the notification appliance circuits (NACs) after a preprogrammed time limit after the last alarm
alarm silence or reset inhibit timer	A panel option that prevents anyone from silencing notification appliance circuits (NACs) or resetting the panel for a programmed period after the last alarm
AND statement	A system input that activates when ALL the input conditions as indicated in its AND statement list, are active
audible circuit	A notification appliance circuit that is turned OFF when the Alarm Silence switch is pressed.
change of state	Occurs whenever an input zone or device changes from a restored to an active condition, or from the active condition back to the restored condition
Class A IDC	A circuit, connected directly to initiating devices, that signals a trouble condition upon an open condition on the circuit. All devices wired on the circuit to continue to operate in the event of a single open. Similar to Style D & E integrity monitoring.
Class A NAC	A circuit, connected directly to notification appliances, that signals a trouble condition upon an open or shorted condition on the circuit. All appliances wired on the circuit to continue to operate in the event of a single open. Similar to Style Z integrity monitoring.
Class B IDC	A circuit, connected directly to initiating devices, that signals a trouble condition upon an open condition on the circuit. All devices wired on the circuit to continue to operate up to the location of a break. Similar to Styles A, B, C, & D integrity monitoring.

Glossary

Class B NAC	A circuit, connected directly to notification appliances, that signals a trouble condition upon an open or shorted condition on the circuit. All appliances wired on the circuit to continue to operate up to the location of a break. Similar to Styles W, X, & Y integrity monitoring.
CMS	Central monitoring station
coder	A device that provides interruption of power to audible devices at a predetermined rate or sequence
command list	<p>A predefined list of SDU commands. You can activate a command list from a rule, from another command list, or from an external command and control system.</p> <p>Users of the ACDB program can specify which command list is executed for an access control event. The RPM exports the command list names (labels) in the resource profile.</p>
compile	To convert data entered during programming into a format used by the fire alarm control panel
CRC	Card Reader Controller
DACT	Digital alarm communicator transmitter. A system component which transmits digital alarm, supervisory, and trouble signals to a central monitoring station (CMS) over dial-up telephone lines. The 3-MODCOM is a DACT.
database	User-defined, permanently stored, system parameters containing system zone definitions, device types, responses, messages, etc.
device	Any Signature Series detector or module
device address	A number that uniquely identifies a detector or module on a Signature data circuit
dialer	See DACT
disable	Prevent an input, output, or system feature from functioning
download	To send a compiled project database from your PC to the system control panel.
EEPROM	Electrically erasable programmable read-only memory. Nonvolatile memory containing the system database.
enable	Permit an input, output, or system feature to function.
EPROM	Erasable programmable read-only memory. Nonvolatile memory containing the operating system. EPROM is erasable only by ultraviolet light.
external command port	An RS-232 connection which permits the CPU module to be connected to a remotely located control system.
fiber optic	Communication format that uses light signals carried on glass fibers to transmit and receive data
flash memory	Nonvolatile read-write memory
global domain	Features which operate in all network cabinets

group	A collection of Signature devices that is treated as a single entity for programming purposes. Groups can have messages and responses over and above the messages and responses of the individual group members.
group domain	Features that operate in a specific group of network cabinets
IDC	Initiating device circuit. An input circuit connected directly to any manual or automatic initiating device, whose normal operation results in an alarm or supervisory signal indication at the control panel. The electrical integrity of the circuit is monitored by the fire alarm system.
input	A signal generated by a field device and sent to the control panel for evaluation and responses as determined by the system database. Inputs to the system are detectors, modules, and switches.
KDC	Keypad Display Configuration program. Software that lets end users create and maintain a security database. The program communicates with the system via 3-MODCOM.
KPDISP	Keypad Display
label	A unique identifier for an object
listing	A printed version of all system configuration data contained in the panel
local domain	Features which operate only within the local cabinet
local system	A system which operates according to the provisions of NFPA 72, Chapter 3
logic functions	AND and OR statements
M device or zone	A monitor device or zone
march time	A 50% duty cycle, 120 beats per minute signal pattern
matrix	A correlation sheet that indicates the relationship between the activation of an input and the effect it will have upon all system outputs
modem	Short for modulator/demodulator. A communications device that enables a computer to transmit information over a standard telephone line. Sophisticated modems are also capable of such functions as automatic dialing, answering, and redialing in addition to transmitting and receiving. The 3-MODCOM includes a modem.
NAC	Notification appliance circuit. A circuit connected directly to notification appliances. The electrical integrity of the circuit is monitored by the fire alarm system.
nonsilenceable	A notification appliance circuit that remains active after initiating, independent of the panel's alarm silence features. Nonsilenceable NACs are typically used for visual devices.
object	Inputs, outputs, and controls which are used as the basis for creating system rules

Glossary

output	A signal generated by the system, based upon responses defined in the system database, and sent to external field devices. Outputs are LEDs, and modules.
output priority	A system of hierarchy that allows or prevents setting or resetting outputs. Output priorities range from low to high.
personality code	A number code used to set the configuration and operation of a SIGA module. A personality code is either factory installed or must be downloaded into SIGA modules for proper operation.
power-limited	Wiring and equipment that conforms with, and is installed to, the National Electrical Code, Article 760, power-limited provisions
proprietary system	A system which operates according to the provisions of NFPA 72, Chapter 4-4
pseudo point	An input or output point that is not a physical device. Example: ground fault and communication fault notification.
PSNI	Positive, successive, non-interfering code
RAM	Random access memory. Volatile memory containing the system online or active status.
reset	An active condition or command used to force an output to its OFF condition. An output's OFF state may be in the restored condition (normal condition, not under the influence of a response) or the reset condition. An output reset state contains a priority level.
response	A list of outputs or functions that occur as a result of the change of state of an input.
restore	Refers to a condition of an input, where the input is not active. It also refers to the condition of an output where the output is not in its SET or RESET condition and does not have a priority value associated with it.
retard	The delay of water flow signals to prevent false alarms due to fluctuations in water pressure.
riser	An electrical path that contains power or signal that is used by multiple outputs, zones, or circuits.
RS-232	A serial communications format normally used for serial peripheral devices (i.e., printers) from a computer. RS-232 cables have a maximum length of 50 ft (15.2M).
RS-485	A serial differential communications format used to communicate between the panel and some remote annunciators.
rule	A logical relationship between objects defined in the network's object list. Rule format:[rule label] (input state) (input device type) 'input label' : Output command (output device type) (priority) 'output label' {comments};
S device or zone	Supervisory device or zone

SDU	EST3 System Definition Utility program. Software that lets programmers configure and program an EST3 integrated system.
sensitivity	The relative percent obscuration of a detector
sequence	A series of actions separated by time delays
service group	A collection of devices that are configured for testing as a group using the system test function
SIGA	An abbreviation for Signature A
Signature data circuit	The wiring which connects Signature Series devices to the fire alarm panel
silenceable	Notification appliance circuits that follow the action of the panel's alarm silence features. Silenceable NACs are used for audible devices only.
SPM	Strokes per minute
start action	An action that is activated upon power-up of the panel and remains active until manually reset
start sequence	A sequence that is begun upon power-up of the panel
supervisory circuit	An IDC input circuit used to monitor the status of critical fire protection equipment, e.g. sprinkler valves
supervisory open (trouble)	Condition generated when a supervisory zone is open, in ground fault, or when a Signature Series device is not responding to a poll
supervisory short	Condition generated when a supervisory zone or device is shorted.
System Definition Utility	A Windows-based program used to enter and modify information contained in the system
TAP protocol	Telocator Alphanumeric Protocol. A communication protocol that lets the EST3 system transmit text messages to suitably equipped and supported alphanumeric pagers, via the 3-MODCOMP.
telco	Telephone company
temporal pattern	A universal 3-pulse evacuation signal meeting the requirements of NFPA Standard 72, section A-2-4.10(a) and ULC 527
time control	An input activated by the time of day or day of the month
verification alarm	Upon receipt of an alarm by a smoke detector, verified detectors attempt to automatically reset. Receipt of a second alarm within the 60-second confirmation period after the automatic detector reset period is indicative of a verified alarm.
waterflow device	Devices or zones defined as waterflow devices are not permitted to silence their notification appliances while the alarm is active

Glossary

zone A group of Signature Series detectors and modules which has a unique zone number and acts as a single entity for programming purposes, whenever any component of the zone is activated

3

- 3-AADC1 with IRC-3 • 5.41
- 3-MODCOM • 3.3, 3.32, 3.34
- 3-RS232 card • 3.34
- 3-SAC
 - description • 3.3
 - device capacity • 3.3

6

- 6 Types of Remote Stations • C.9

A

- AC power and battery wiring • 5.42
- AC power source application • 3.39
- AC power supply
 - elevator control application • 3.23
 - remote controls application • 3.46
- Access control • C.8
- access control applications • 3.1
- access control system diagram • 3.2
- access events
 - command lists in SDU • 3.15
- access levels
 - visitors • 3.31
- ACDB
 - 3-MODCOM receiving function • 3.3
 - computer location in muster • 3.32
 - configuring CRC • 3.8
 - CRCSND configuration • 3.4
 - description • 3.7
 - door timers • 3.9
 - role in a security system • 3.9
 - transmission methods • 3.7
- ACDB operation
 - common door access • 3.17
 - delayed egress • 3.20
 - emergency exit door • 3.25
 - handicap access door • 3.27
 - intermittent locks • 3.38
 - multiple card readers • 3.31
 - power for intermittent locks • 3.38
- adding hardware • 8.6
- additional card readers • 3.27
- additional power supplies • 3.4, 3.8
- Addressable analog
 - module troubleshooting • 8.75
- alarm
 - sensitivity • 1.26
- alert channel • 1.37
- all call • 1.35
- all call minus • 1.35
- alternate alarm sensitivity • 1.27
- alternate alarm verification • 1.27
- alternate prealarm setting • 1.28
- amplifier
 - backup • 1.8

- amplifier • 1.7
 - audio • 4.8
 - backup • 1.34
 - output voltage • 1.33
 - output wattage • 1.33
 - wiring considerations • 1.34
- amplifier selection • 1.33
- Amplifier Terminal Panel • 4.3, 4.6
 - installation • 4.13
- anti-passback
 - muster application • 3.11
- anti-passback application • 3.11
- application descriptions
 - AC power source • 3.39
 - anti-passback • 3.11
 - central monitoring station • 3.14
 - common door access • 3.16
 - continuous locks • 3.35
 - DC power supply • 3.42
 - delayed egress • 3.18
 - elevator control • 3.21
 - emergency exit door • 3.24
 - handicap access door • 3.26
 - intermittent locks • 3.37
 - maglock peripherals • 3.28
 - multiple card readers • 3.30
 - muster • 3.32
 - power for continuous locks • 3.35
 - power for intermittent locks • 3.37
 - power from a remote source • 3.42
 - power from an AC source • 3.39
 - remote controls • 3.45
 - remote power source • 3.42
 - remote power source application • 3.42
 - two-person rule • 3.47
- audio
 - channels • 1.34
 - signal priority • 1.10
 - synchronization • 5.6
 - zoning • 1.33
- audio amplifiers • 8.21
- audio source unit • 1.9
- automatic door openers • 3.6, 3.26

B

- badging in • 3.32
- bar code card • 3.30
- batteries
 - compatibility list • 3.5
 - CRC option • 3.5
 - description • 3.5
 - limitations of CRC battery • 3.41
- battery calculations • B.20
- booster power supply • 8.9
- bypass time
 - delayed egress application • 3.20
 - emergency exit door application • 3.25

Index

C

- cabinet coverage • 1.29
- cable properties • B.3
- cables
 - SAC bus • 3.3
- calculating maximum wire capacitance per foot • B.4
- capacitance of SAC bus • 3.3
- card access equipment • 3.2
- card readers
 - additional • 3.27
 - anti-passback application • 3.11
 - definition • 3.6
 - dual LED control • 3.31, 3.48
 - handicap access door application • 3.26
 - two-person rule application • 3.48
- central monitoring station application • 3.14
- central monitoring stations • 3.3
- Central station connection using FireWorks • C.4
- Central station with local bell timeout using a 3-MODCOM • C.5
- Central station via 3-MODCOM • C.6
- chain errors • 8.55
- chassis
 - 19-inch rack installation • 5.22
- circuit common • 3.8, 3.23, 3.44, 3.46
- circuit modules
 - removing or replacing • 8.4
- command lists
 - events with • 3.15
 - multiple card readers application • 3.31
 - muster application • 3.34
 - remote controls application • 3.46
 - two-person rule application • 3.49
- common door access application • 3.16
- communication fault • 8.64
- compiler errors • 6.4
- configuring CRC • 3.8
- continuous locks • 3.35
- continuous locks application • 3.35
- CPU memory calculations • B.26
- CRC
 - description • 3.4
- CRC
 - battery • 3.5
 - input circuits • 3.5
 - jumpers • 3.8
 - lock output • 3.7
 - options • 3.4
 - output circuits • 3.6
 - power supply from cabinet • 3.8
 - resetting • 3.18, 3.19, 3.20
- CRCRL • 3.4
- CRCNSD
 - delayed egress application • 3.18
 - description • 3.4
 - emergency exit door application • 3.24
 - installation • 3.4
- CRCXF • 3.5

D

- data network specifications • B.2
- DC power supply application • 3.42
- delayed egress application • 3.18
- delayed egress time • 3.18, 3.19
- design considerations
 - audio applications • 1.33

- design considerations
 - firefighter telephone • 1.42
- detector cleaning • 7.6
- device sharing • 3.17
- device trouble • 8.59
- device type
 - PIR in maglock peripherals • 3.29
- device type fault • 8.63
- diagnostic tools
 - addressable analog • 8.70
 - Signature • 8.51
- direct connect to panel • 3.7, 3.32
- door ajar sounder • 3.4
- door contact
 - CRC input circuit • 3.5
 - delayed egress application • 3.19, 3.20
 - emergency exit door application • 3.24, 3.25
- door holders • 3.6
- door open timer • 3.9
- downloading
 - problems • 8.6
- dual LEDs • 3.6, 3.31, 3.48
- dummy loads • 3.23, 3.34

E

- elevator control application • 3.21
- emergency exit door application • 3.24
- emergency exit sounder • 3.4
- emergency exit sounder time • 3.20, 3.25
- energized system precaution • 5.3
- equipment
 - basic access control system • 3.2
- error messages • 8.53
- ESD precaution • 5.3
- evacuation (EVAC) channel • 1.37
- external modem
 - connecting for the remote diagnostics utility • 5.53

F

- feature/function domain • 1.30
- fiber optic cable worksheet • B.28
- firefighter telephone • 1.15
- floor access • 3.21

G

- general channel • 1.37
- ground fault • 8.64
- ground fault detection • 3.8, 3.44, 3.46
- ground faults • 8.78
 - Signature data circuit • 8.39

H

- handicap
 - privileges • 3.26
 - timers • 3.27
- handicap access door application • 3.26
- hardware
 - adding • 8.6
 - substitution • 8.5
- hardware problems • 8.5
- high and low card readers • 3.30
- Holdup alarm • C.8

I

- input circuits
 - delayed egress application • 3.20
 - description • 3.5
 - dummy loads • 3.23
 - elevator control application • 3.23
 - emergency exit door application • 3.24, 3.25
- intermittent locks • 3.37
- internal fault • 8.63
- IRC-3 upgrade • 5.41

J

- jumper settings
 - AC power source • 3.41
 - continuous locks • 3.36
 - DC power supply • 3.44
 - intermittent locks • 3.38
 - remote power supply • 3.44
- jumpers • 3.8

K

- keypads
 - description • 3.6

L

- LEDs
 - dual LED control • 3.31, 3.48
- length of SAC bus • 3.3
- lobbies • 3.16
- Local mercantile premises • C.3
- lock circuit dummy loads
 - elevator control application • 3.23
 - muster station • 3.34
- lock types
 - intermittent locks • 3.38
- locks
 - CRC output • 3.7
 - CRCRL and external power supply • 3.4
 - logged anti-passback • 3.11

M

- maglock peripherals application • 3.28
- maglocks
 - code requirements • 3.28
 - CRC output • 3.7
 - delayed egress application • 3.19
- magnetic stripe access cards • 3.6
- maintenance philosophy • 8.3
- manual audio zone selection • 1.38
- mapping errors • 8.47, 8.52
- message counters
 - Signature • 8.57
- messages • 1.39
 - alarm format • 1.39
 - alert format • 1.40
 - automatic • 1.14
 - default • 1.14
- modem transmission • 3.7
- motion detectors • 3.5
- multiple card readers application • 3.30
- multiple tenants • 3.16
- muster
 - 3-RS232 card • 3.34

- partitions • 3.34
- report • 3.32
- timed anti-passback • 3.11
- muster application • 3.32
- muster station
 - requirements • 3.32, 3.34

N

- N.C. contacts • 3.6
- N.O. contacts • 3.6
- NAC circuit calculations • B.11
- NAC synchronization • 5.6
- network
 - applications and design considerations • 1.29
 - layout • 1.29
- network data riser
 - cable properties • B.3
 - length • B.3
 - limits • B.2
 - specifications • B.2
 - wire capacitance • B.4
- NFPA 101
 - delayed egress • 3.18
 - emergency exit door • 3.24
- NFPA standards • C.2
- notification zones • 5.8

O

- open fault • 8.64
- output circuits • 3.6

P

- page channel • 1.35
- page to alert • 1.35
- page to evac • 1.35
- pager messages • 3.3
- panel controller • 8.9
- partitions
 - muster application • 3.34
- passive infrared motion detector • 3.28, 3.29
- peripherals required for maglocks • 3.28
- personality fault • 8.63
- PIN schedules • 3.6
- Police station connection • C.3
- power
 - elevator control application • 3.23
 - transformer • 3.5
- power for continuous locks application • 3.35
- power for intermittent locks application • 3.37
- power from a remote source application • 3.42
- power from an AC source application • 3.39
- power supplies
 - AC power source • 3.41
 - circuit common • 3.8, 3.23, 3.44, 3.46
 - continuous locks application • 3.36
 - DC power supply • 3.42, 3.44
 - elevator control application • 3.23
 - ground fault detection • 3.8
 - intermittent locks application • 3.38
 - jumper settings • 3.8
 - panel • 3.8
 - power from a remote source • 3.44
 - power from a remote source application • 3.42
 - power from an AC source application • 3.39
 - remote controls • 3.46

Index

- remote power source • 3.44
- transformer • 3.8
- transformer source • 3.41
- power wiring • 5.42
- power-up procedure • 6.3
- prealarm
 - setting • 1.27
- preventive maintenance
 - schedule • 7.3
- primary power supply • 8.7
- priority
 - audio channel • 1.34
- problem classification • 8.3
- Proprietary using 3-MODCOM or FireWorks • C.7
- Proprietarywith standard line security • C.7
- proximity cards • 3.6
- pseudo point descriptions • 8.24

R

- rack mounting • 5.22
- racks
 - equipment • 4.3
- reader terminal dummy loads • 3.34
- recommended spares list • 8.4
- record of completion • 6.24
- remote controls application • 3.45
- remote power source application • 3.42
- remote power supply wiring diagram • 3.44
- request to exit buttons • 3.5, 3.18, 3.20
- requirements for UL security applications • C.3
- resetting the CRC • 3.18, 3.25
- resistance of SAC bus • 3.3
- resource allocation • 3.17
- resource profiles • 3.7, 3.17
- response lists • 8.56
- RPM • 3.7, 3.17

S

- SAC bus
 - 3-SAC module • 3.3
 - description • 3.3
 - elevator control application wiring • 3.23
 - EOL resistor • 3.34
 - wiring • 3.3
- SAC bus power calculations • B.21
- SDU
 - configuring CRC • 3.8
 - CRCSND programming • 3.4
 - role in a security system • 3.8
- second card reader • 3.26
- security devices • 3.5
- selecting a page destination • 1.35
- selective page • 1.35
- sensitivity fault • 8.63
- sharing devices • 3.17
- short fault • 8.64
- SIGA-AAxx • 8.21
- Signature
 - detector troubleshooting • 8.60
 - diagnostic tools • 8.51
 - module troubleshooting • 8.49, 8.61
 - real time status • 8.65
 - trouble tables • 8.62
- Signature controller module • 3.46
- Signature data circuit
 - basic troubleshooting • 8.37

- branch length • B.5
- determining total length • B.10
- ground faults • 8.39
- operation • 8.35
- wire length • B.5
- Signature relays
 - elevator control application • 3.21
 - remote controls application • 3.46
- smart cards • 3.6
- static-sensitive handling • 8.3
- strict anti-passback • 3.11
- strikes
 - description • 3.7
- strobe
 - synchronization • 5.6
- substituting hardware • 8.5
- substituting known good Signature series devices • 8.41
- synchronization of NACs • 5.6
- system description • 1.2

T

- testing
 - control and emergency communications • 6.7
 - initial and reacceptance • 6.6
 - initiating devices • 6.21
 - notification appliances • 6.23
- timed anti-passback • 3.11
- transformers
 - AC power source application • 3.39
 - circuit common • 3.8
 - CRCXF CRC Transformer • 3.5
 - elevator control application • 3.23
 - remote controls application • 3.46
 - wiring diagram • 3.41
- trouble and maintenance log • 7.7
- trouble registers • 8.59
- trouble tables
 - Signature • 8.62
- troubleshooting
 - wiring problems • 8.77
- two-person rule
 - dual LED control • 3.6
- two-person rule application • 3.47

U

- UL and ULC requirements • C.10
- UL security application requirements • C.3
- unexpected fault • 8.63
- uninterruptible power supply • 5.48
- Universal Riser Supervisory Module • 4.10
- unlock timer • 3.9

V

- visitor access level • 3.31
- visitor and escort
 - dual LED control • 3.6
 - multiple card readers application • 3.30

W

- Wiegand pin cards • 3.6
- wire length calculations
 - 24 Vdc notification appliance circuits • B.11
 - 25 or 70 Vrms notification appliance circuits • B.17

- addressable analog data circuits • B.19
- network data riser • B.2, B.3
- notification appliance circuits • B.11
- Signature data circuits • B.5
- wiring
 - branch speaker circuit • 4.25
 - card readers • 3.27
 - circuit common • 3.8, 3.23, 3.44, 3.46
 - DC power supplies • 3.44
 - ground fault detection • 3.8, 3.44, 3.46
 - remote power supplies • 3.44
 - SAC bus • 3.3
 - transformers • 3.41
 - wiring problems • 8.77

